



## Features

- 2.54 mm pitch & height
- 2 to 6 precious metal contacts
- End-to-end stackable
- Twin hot contacts (symmetrical pad layout)
- Pick & place compatible
- High cycle life
- RoHS compliant\* - see [processing information](#) for RoHS compliant surface mount components
- Halogen free\*\*

## 70AA/Male - Modular Contact

### Materials & Finishes

Insulator.... Glass reinforced thermoplastic, UL 94V-0 rated, black  
 Contact.....Copper alloy  
 Finish  
 Underplating..... 30 μ" min. Ni  
 Contact Area ..... 30 μ" min. Au over Ni

### Operating Characteristics

Electrical  
 Current Rating..... 3 A/contact  
 Voltage Rating.....60 V  
 Contact Resistance..... 25 mohms max.  
 Dielectric Voltage .....AC 500 V  
 Insulating Resistance.. 1000 Mohms min.  
 Operating Temperature  
 .....-55 °C to 125 °C

Mechanical  
 Vibration..... 30 G, 10-2K Hz, 0.06 inches D.A.  
 Shock..... 100 G  
 Normal Force ..... 80 grams min. at a working height of 0.25 mm (0.010 inches)  
 Durability ..... 50,000 cycles min.  
 Contact Resistance after 50,000 Cycles ..... 50 mΩ  
 MSL ..... 1  
 ESD Rating (HBM) .....3B

### How to Order

**70AA J - 4 - M 0 G**

Model \_\_\_\_\_  
 Terminal Style \_\_\_\_\_  
 J = SMT  
 Number of Contacts (N) \_\_\_\_\_  
 2 through 6  
 Gender \_\_\_\_\_  
 M = Male  
 Options \_\_\_\_\_  
 0 = Standard  
 Packaging Option (MSL-1) \_\_\_\_\_  
 \_ = Tube  
 G = Embossed Tape (750 pcs. per reel)

### Product Dimensions

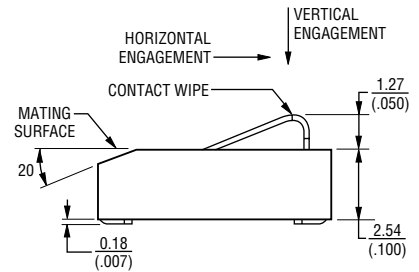
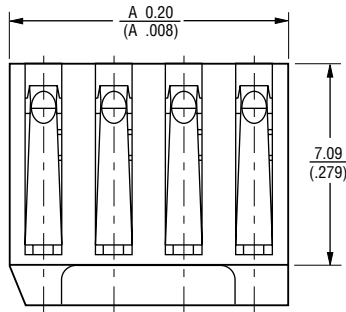

### Recommended PWB Layout

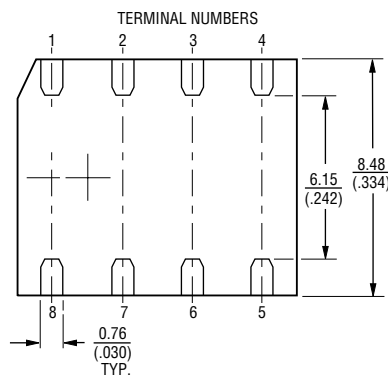
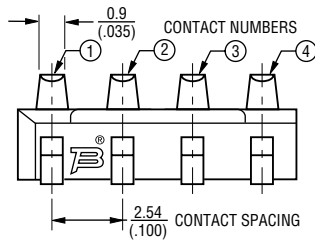
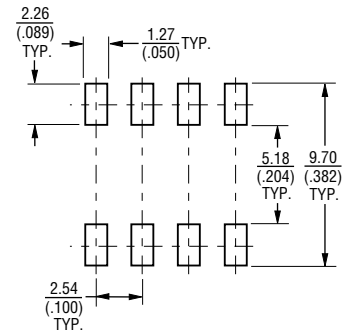

### Electrical Schematic

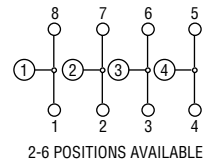

Number of Contacts	Dimension A
2	5.00 (.197)
3	7.54 (.297)
4	10.20 (.397)
5	12.62 (.497)
6	15.16 (.597)

TOLERANCES:  $\pm 0.3$   
( $\pm 0.12$ ) UNLESS OTHERWISE NOTED

DIMENSIONS:  $\frac{\text{MM}}{(\text{INCHES})}$

\* RoHS Directive 2002/95/EC Jan. 27, 2003 including annex and RoHS Recast 2011/65/EU June 8, 2011.  
 \*\* Bourns considers a product to be "halogen free" if (a) the Bromine (Br) content is 900 ppm or less; (b) the Chlorine (Cl) content is 900 ppm or less; and (c) the total Bromine (Br) and Chlorine (Cl) content is 1500 ppm or less.

Specifications are subject to change without notice.  
 The device characteristics and parameters in this data sheet can and do vary in different applications and actual device performance may vary over time.  
 Users should verify actual device performance in their specific applications.

# 70AA/Male - Modular Contact

**BOURNS®**

## Packaging Specifications

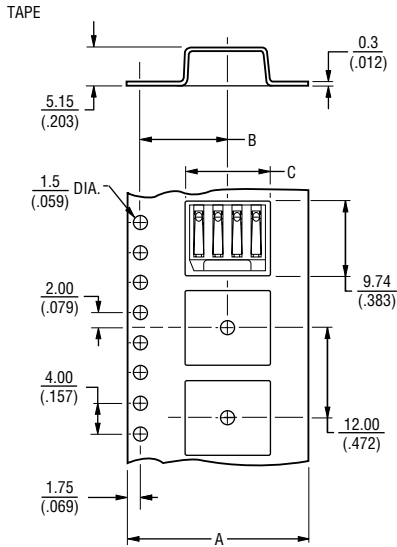

No. of Contacts	Dimension A	Dimension B	Dimension C	Dimension D
2	$\frac{16.0}{(.630)}$	$\frac{7.5}{(.296)}$	$\frac{5.64}{(.222)}$	$\frac{16.4}{(.646)}$
3	$\frac{16.0}{(.630)}$	$\frac{7.5}{(.296)}$	$\frac{8.19}{(.323)}$	$\frac{16.4}{(.646)}$
4	$\frac{24.0}{(.945)}$	$\frac{11.5}{(.453)}$	$\frac{10.4}{(.409)}$	$\frac{24.4}{(.961)}$
5	$\frac{24.0}{(.945)}$	$\frac{11.5}{(.453)}$	$\frac{12.95}{(.510)}$	$\frac{24.4}{(.961)}$
6	$\frac{24.0}{(.945)}$	$\frac{11.5}{(.453)}$	$\frac{15.5}{(.610)}$	$\frac{24.4}{(.961)}$

DIMENSIONS:  $\frac{\text{MM}}{\text{(INCHES)}}$

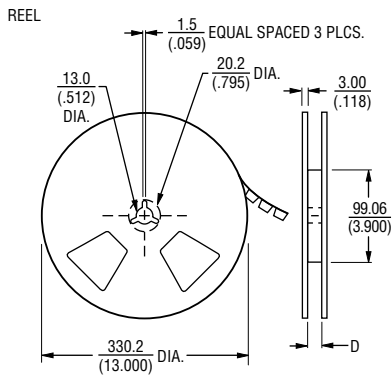

REV. 06/17

Specifications are subject to change without notice.  
 The device characteristics and parameters in this data sheet can and do vary in different applications and actual device performance may vary over time.  
 Users should verify actual device performance in their specific applications.