

Customer Information Sheet

DRAWING No.: M80-460XXXX

SHEET 2 OF 2

IF IN DOUBT - ASK

(C)

NOT TO SCALE

THIRD ANGLE PROJECTION

ALL DIMENSIONS IN mm

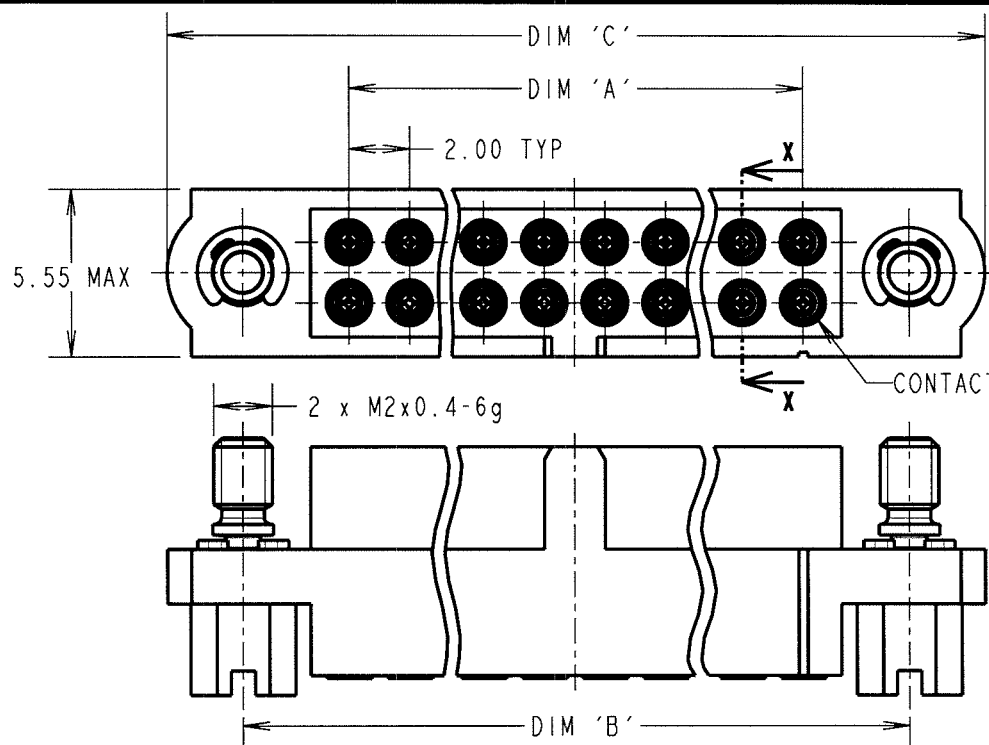

PART SECTION X-X

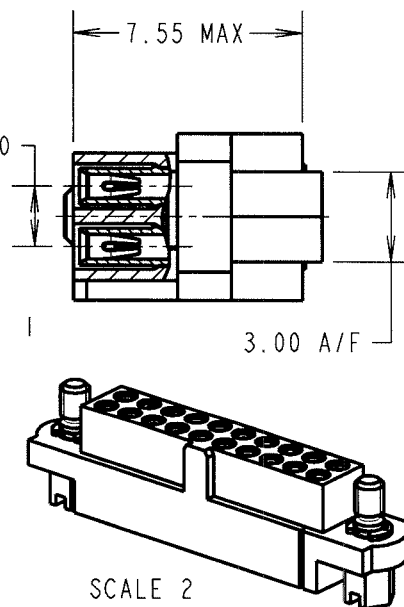

SPECIFICATIONS:

MATERIAL:
 MOULDING = GLASS-FILLED PPS, UL94V-0, BLACK
 CONTACT CLIP = BERYLLIUM COPPER
 CONTACT SHELL = BRASS
 JACKSCREW, CIRCLIP = STAINLESS STEEL

FINISH:
 01 = 0.3µ GOLD CLIP, 3.5-5.0µ TIN SHELL
 05 = 0.3µ GOLD CLIP, 0.25-0.3µ GOLD SHELL

ELECTRICAL:
 CURRENT RATING AT 25°C = 3.0A MAX
 CURRENT RATING AT 85°C = 2.2A MAX
 WORKING VOLTAGE = 120V AC/DC
 VOLTAGE PROOF = 360V AC/DC
 CONTACT RESISTANCE = 25 mΩ MAX
 INSULATION RESISTANCE = 100 MΩ MIN

MECHANICAL:
 DURABILITY = 500 OPERATIONS
 INSERTION FORCE (∅0.5mm GAUGE) = 2.8N MAX
 WITHDRAWAL FORCE (∅0.5mm GAUGE) = 0.2N MIN

ENVIRONMENTAL:
 TEMPERATURE RANGE = -55°C TO +125°C

PACKING:
 LOOSE
 FOR COMPLETE SPECIFICATION, SEE
 COMPONENT SPECIFICATION C005XX
 (LATEST ISSUE)

ASSEMBLY PART No.	No. OF CONTACTS	DIM 'A'	DIM 'B'	DIM 'C'
M80-46006XX	6	4.00	11.00	16.00
M80-46010XX	10	8.00	15.00	20.00
M80-46012XX	12	10.00	17.00	22.00
M80-46014XX	14	12.00	19.00	24.00
M80-46020XX	20	18.00	25.00	30.00
M80-46026XX	26	24.00	31.00	36.00
M80-46034XX	34	32.00	39.00	44.00
M80-46042XX	42	40.00	47.00	52.00
M80-46050XX	50	48.00	55.00	60.00

ORDER CODE:

M80-460XXXX

TOTAL No. OF CONTACTS
 06, 10, 12, 14, 20,
 26, 34, 42, 50

FINISH

01 - GOLD CLIP, TIN SHELL
 05 - GOLD CLIP, GOLD SHELL

NOTES:

- CONNECTORS ARE SUPPLIED WITH CONTACTS LOOSE.
- FOR EXTRA CONTACTS, USE PART NUMBER M80-01100XX (XX = SAME FINISH CODE AS ASSEMBLY).
- RECOMMENDED WIRE TYPE = BS 3G 210 TYPE A, PTFE INSULATED 22 AWG. MAX INSULATION DIAMETER = ∅1.10mm, STRIP WIRE BY 2.00mm.
- RECOMMENDED HAND CRIMP TOOL = M22520/2-01 WITH POSITIONER T5747.
- CONTACT INSERTION AND EXTRACTION TOOL = Z80-280
- INSTRUCTION SHEETS ARE AVAILABLE.

JMB	C	11.07.05	8619
NAME	ISS.	DATE	C/NOTE
APPROVED:	<i>[Signature]</i>		
CHECKED:	<i>[Signature]</i>		
DRAWN:	W. J. BOURNE		
CUSTOMER REF.:			
ASSEMBLY DRG:			

HARWIN

THIS DRAWING AND ANY INFORMATION OR DESCRIPTIVE MATTER SET OUT HEREON ARE CONFIDENTIAL AND COPYRIGHT PROPERTY OF THE HARWIN GROUP AND MUST NOT BE DISCLOSED, LOANED, COPIED OR USED FOR MANUFACTURING, TENDERING OR FOR ANY OTHER PURPOSE WITHOUT THEIR WRITTEN PERMISSION.

TOLERANCES
 X. = ±1mm
 X.X = ±0.25mm
 X.XX = ±0.10mm
 X.XXX = ±0.01mm
 ANGLES = ±5°
 UNLESS STATED

MATERIAL:
 SEE ABOVE
FINISH:
 SEE ABOVE
S/AREA:
 mm²

TITLE: JACKSCREW DATAMATE
 DIL CRIMP (LARGE BORE)
 FEMALE ASSEMBLY
DRAWING NUMBER:
M80-460XXXX
 SHT 2 OF 2

HARWIN INC U.S.A.
 TEL: (812) 542 2540 FAX: (812) 542 2541

HARWIN PLC U.K.
 TEL: 023 9231 4545 FAX: 023 9231 4590

HARWIN PTE SINGAPORE
 TEL: 65 6779 4909 FAX: 65 6779 3868