

Customer Information Sheet

DRAWING No.: M80-540XX22

SHEET 2 OF 2

IF IN DOUBT - ASK

©

NOT TO SCALE

THIRD ANGLE PROJECTION

ALL DIMENSIONS IN mm

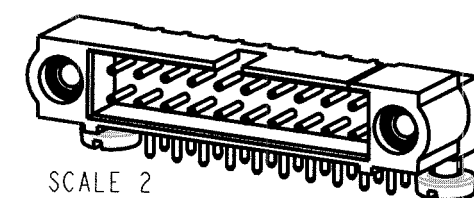
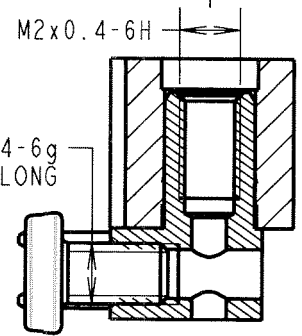
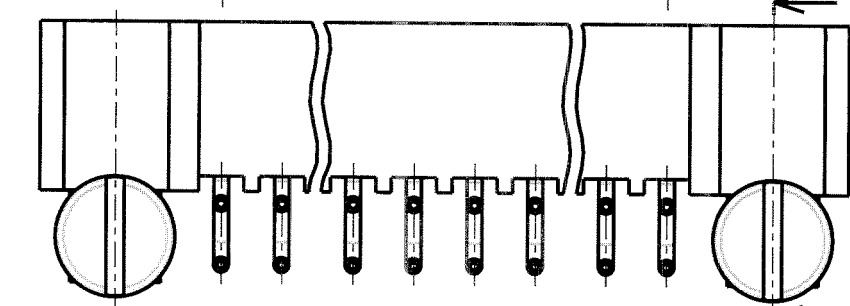
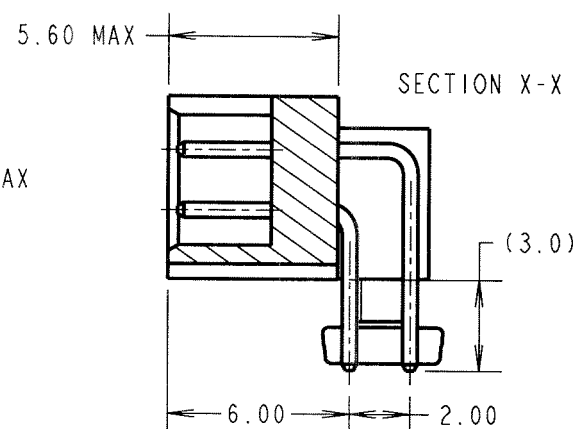
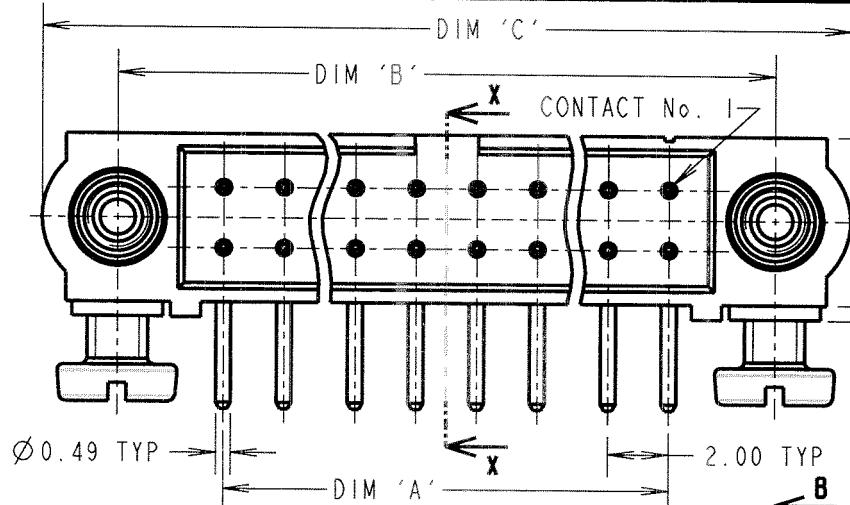

SPECIFICATIONS:
MATERIAL:
 MOULDING = GLASS-FILLED PPS, UL94V-0, BLACK
 CONTACT = PHOSPHOR BRONZE
 JACKSCREW = STAINLESS STEEL
FINISH:
 CONTACT = 0.75µ GOLD ON CONTACT AREA, 3µ 90/10 TIN/LEAD ON TAILS
ELECTRICAL:
 CURRENT RATING AT 25°C = 3.0A MAX
 CURRENT RATING AT 85°C = 2.2A MAX
 WORKING VOLTAGE = 120V AC/DC
 VOLTAGE PROOF = 360V AC/DC
 CONTACT RESISTANCE = 25 mΩ MAX
 INSULATION RESISTANCE = 100 MΩ MIN
MECHANICAL:
 DURABILITY = 500 OPERATIONS
ENVIRONMENTAL:
 TEMPERATURE RANGE = -55°C TO +125°C
PACKING:
 TUBE
 FOR COMPLETE SPECIFICATION, SEE COMPONENT SPECIFICATION C005XX (LATEST ISSUE)

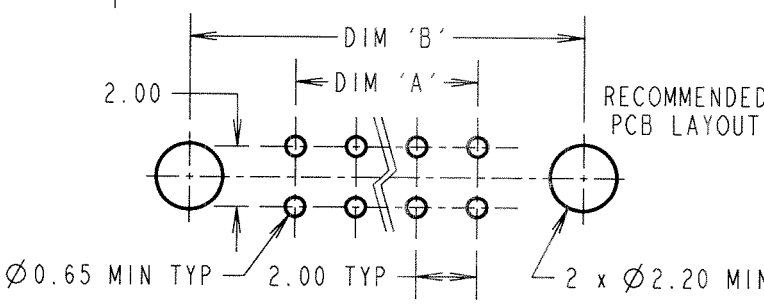

ORDER CODE:
M80-540XX22
 No. OF CONTACTS
 06, 10, 14, 20,
 26, 34, 42, 50
 FINISH
 22 - SELECTIVE GOLD

ASSEMBLY PART No.	No. OF CONTACTS	DIM 'A'	DIM 'B'	DIM 'C'
M80-5400622	6	4.00	11.00	16.00
M80-5401022	10	8.00	15.00	20.00
M80-5401422	14	12.00	19.00	24.00
M80-5402022	20	18.00	25.00	30.00
M80-5402622	26	24.00	31.00	36.00
M80-5403422	34	32.00	39.00	44.00
M80-5404222	42	40.00	47.00	52.00
M80-5405022	50	48.00	55.00	60.00

JAE	B	17.06.04	8028
NAME	ISS.	DATE	C/NOTE
APPROVED: <i>[Signature]</i>			
CHECKED: <i>[Signature]</i>			
DRAWN: W. J. BOURNE			
CUSTOMER REF.:			
ASSEMBLY DRG.:			



HARWIN INC U.S.A.
 TEL: (812) 542 2546 FAX: (812) 542 2541

HARWIN PLC U.K.
 TEL: 023 9231 4545 FAX: 023 9231 4590

HARWIN PTE SINGAPORE
 TEL: 65 6779 4909 FAX: 65 6779 3868

THIS DRAWING AND ANY INFORMATION OR DESCRIPTIVE MATTER SET OUT HEREON ARE CONFIDENTIAL AND COPYRIGHT PROPERTY OF THE HARWIN GROUP AND MUST NOT BE DISCLOSED, LOANED, COPIED OR USED FOR MANUFACTURING, TENDERING OR FOR ANY OTHER PURPOSE WITHOUT THEIR WRITTEN PERMISSION.

TOLERANCES
 X. = ±1mm
 X.X = ±0.25mm
 X.XX = ±0.10mm
 X.XXX = ±0.01mm
 ANGLES = ±5°
 UNLESS STATED

MATERIAL: SEE ABOVE
FINISH: SEE ABOVE
S/AREA: mm²

TITLE: JACKSCREW DATAMATE DIL HORIZONTAL PC TAIL MALE ASSEMBLY (BOARD MOUNT)
DRAWING NUMBER: M80-540XX22
 SHT 2 OF 2