

P	LTR	DESCRIPTION	ECN	DATE	DMN	APVD
A		RELEASE	FK00-0016-04	16-JAN-04	H.S	A.N
B		REVISE VDE LOGO	ECO-07-001278	3-JAN-07	K.S.L	W.Y
C		CHANGE NEW LOGO	ECO-08-019312	6-MAR-09	D.L	BH.Y

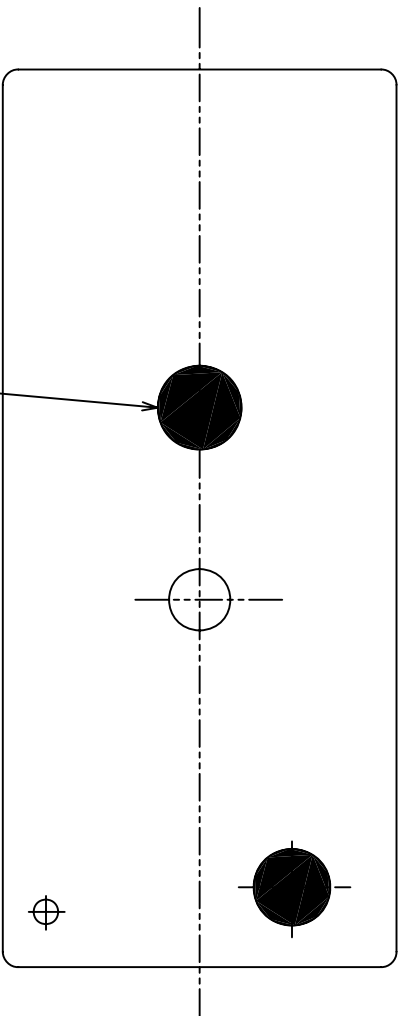

DOT MARK:BLACK
 PART A PART B C:MADE IN CHINA

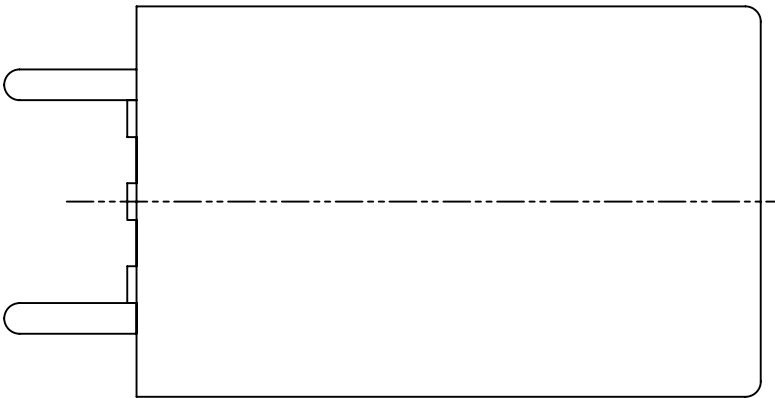
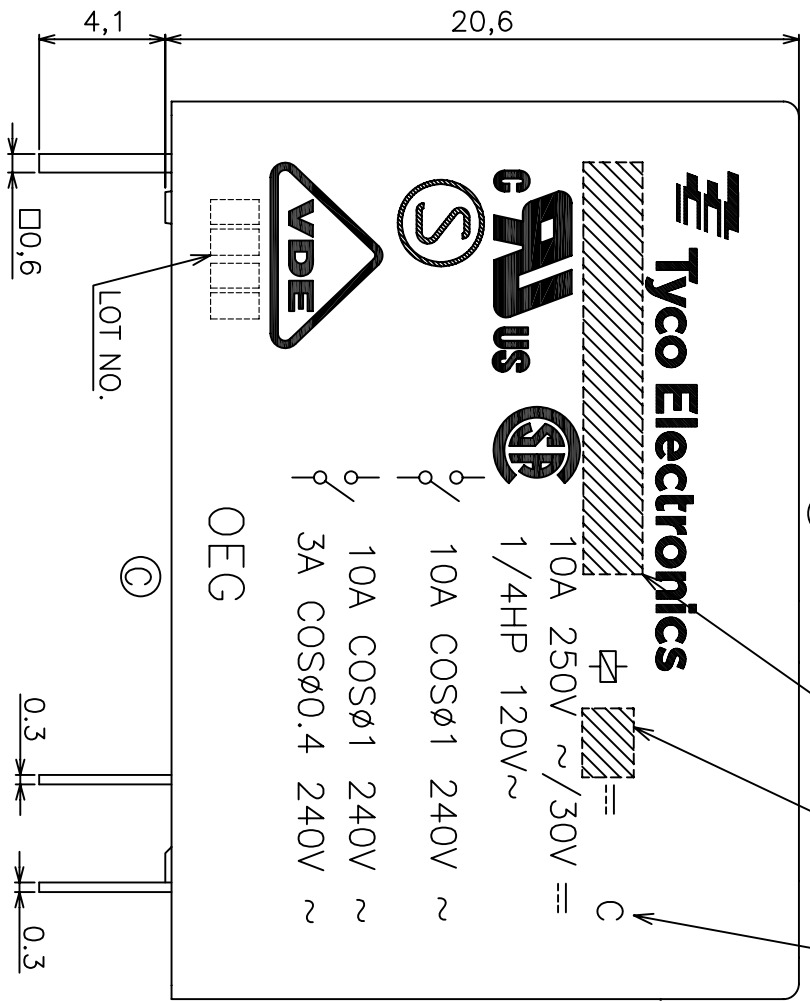

CONNECTION DIAGRAM
 (BOTTOM VIEW)

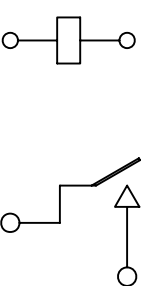

DRILLING DIAGRAM(2/1)
 (BOTTOM VIEW)

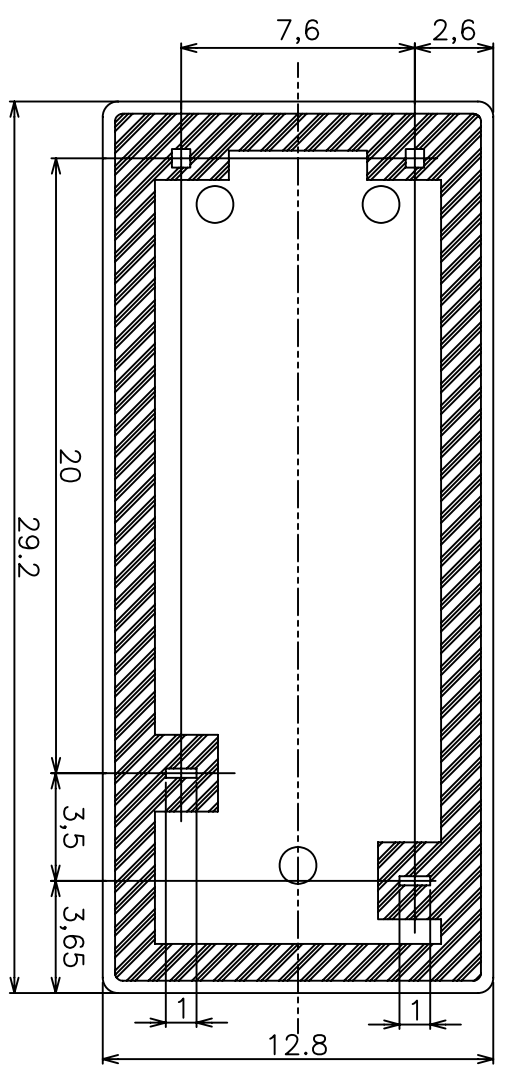
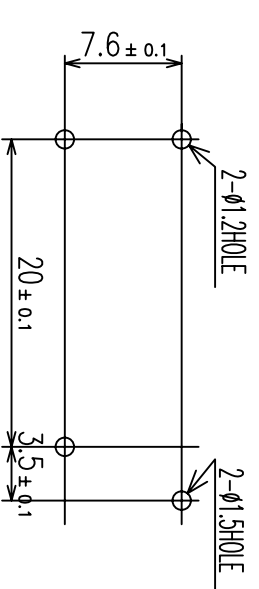

THIS DRAWING IS A CONTROLLED DOCUMENT FOR TYCO ELECTRONICS CORPORATION
 IT IS SUBJECT TO CHANGE AND THE CONTROLLING ENGINEERING ORGANIZATION
 SHOULD BE CONTACTED FOR THE LATEST REVISION.

DMN	H.SASAKI	NAME	0MI-SH-LM CUSTOMER DRAWING		
CHK	Y.OIKAWA		Tyco Electronics Corporation Shenzhen, China		
APVD	A.NAGAI				
PRODUCT SPEC	-				
APPLICATION SPEC	-				
WEIGHT	-				

DIMENSIONS:		TOLERANCES UNLESS OTHERWISE SPECIFIED:	
mm		0 P/C	±
		1 P/C	±
		2 P/C	±
		3 P/C	±
		4 P/C	±
		ANGLES	±
MATERIAL	-	FINISH	-
CUSTOMER DRAWING		SIZE	A3
		CAGE CODE	00779
		DRAWING NO	9-1419121-4
		SCALE	4:1
		SHEET	1 OF 2
		REV	C

THIS DRAWING IS UNPUBLISHED.
© COPYRIGHT BY TYCO ELECTRONICS CORPORATION. ALL RIGHTS RESERVED.

RELEASED FOR PUBLICATION

LOC HB
DIST

REVISIONS

P	LTR	DESCRIPTION	ECN	DATE	DMN	APVD

- NOTES:
 1.-SH- : WASHABLE TYPE
 1.LOT NO. SYSTEM AS FOLLOWING:
 0701
 WEEK YEAR

2.GENERAL TOLERANCE AS FOLLOWING:

TOLERANCE	
0~0.99mm	±0.1
1mm~2.99mm	±0.2
3mm MIN.	±0.3

3.TERMINAL DIMENSION IS NOT INCLUDING SOLDER TIP.

RELAY TYPE	TE PART NO	DESCRIPTION	PART B	PART A
	9-1419121-5	OMI-SH-109LM	9V	OMI-SH-109LM
	9-1419121-4	OMI-SH-105LM	5V	OMI-SH-105LM

		UV RESIN	UV SEAL	17
		EPOXY RESIN	SEAL	16
UL94 V-0		PBT	CASE	15
		—	TAPE	14
CLASS E		VEW	MAGNETIC WIRE	13
UL94 V-0		PET	BASE	12
UL94 V-0		PBT	BOBBIN	11
		CP WIRE	COIL TERMINAL	10
UL94 V-0		PPS	CARD	9
		Ag ALLOY	MOVABLE CONTACT	8
		Ag ALLOY	STATIONARY CONTACT	7
		Cu ALLOY	HINGE SPRING	6
		Cu ALLOY	STATIONARY TERMINAL	5
		SOLDER DIP	MOVABLE SPRING	4
		STEEL	CORE	3
		STEEL	ARMATURE	2
		STEEL	YOKE	1
INCOMBUSTIBILITY	TREATMENT	MATERIAL	DESCRIPTION	ITEM

THIS DRAWING IS A CONTROLLED DOCUMENT FOR TYCO ELECTRONICS CORPORATION
IT IS SUBJECT TO CHANGE AND THE CONTROLLING ENGINEERING ORGANIZATION
SHOULD BE CONTACTED FOR THE LATEST REVISION.

DIMENSIONS: mm
TOLERANCES UNLESS OTHERWISE SPECIFIED:
0 P/C ±
1 P/C ±
2 P/C ±
3 P/C ±
4 P/C ±
ANGLES ±

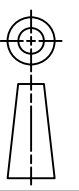

MATERIAL FINISH

DMN
CHK
APVD
PRODUCT SPEC
APPLICATION SPEC
WEIGHT
CUSTOMER DRAWING

Tyco Electronics
Tyco Electronics Corporation
Shenzhen, China

OMI-SH-LM CUSTOMER DRAWING

SIZE	CAGE CODE	DRAWING NO	RESTRICTED TO
A3	00779	9-1419121-4	—

SCALE 4:1 SHEET 2 OF 2 REV C