

THIS DRAWING IS UNPUBLISHED. RELEASED FOR PUBLICATION
 © COPYRIGHT BY TYCO ELECTRONICS CORPORATION. ALL RIGHTS RESERVED.

LOC DIST
 HB

REVISIONS						
P	LTR	DESCRIPTION	ECN	DATE	DWN	APVD
	C1	REACTIVE	ECO-06-022630	29-SEP-06	Y.X	N.F
	D	VDE MARKING CHANGE	ECO-07-001278	21-NOV-06	KS.L	XN.Z
	E	CHANGE NEW LOGO	ECO-08-019312	26-SEP-08	MH.L	BH.Y

D
C
B
A

D
C
B
A

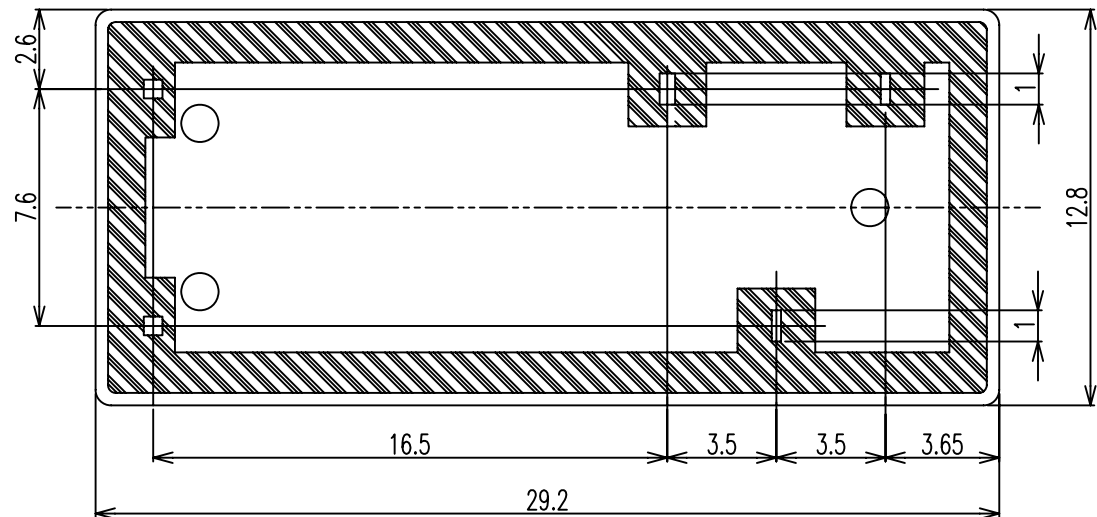
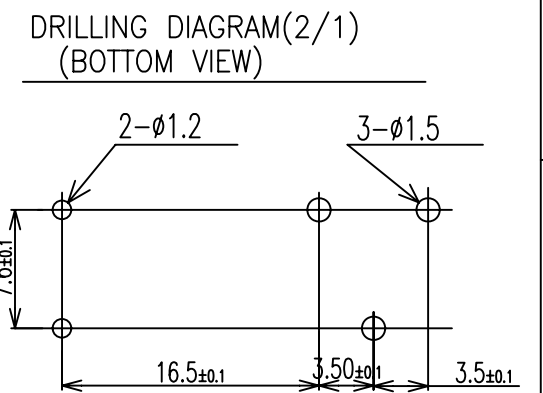
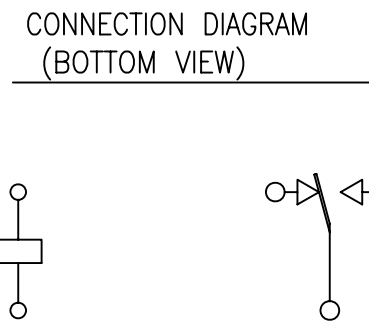
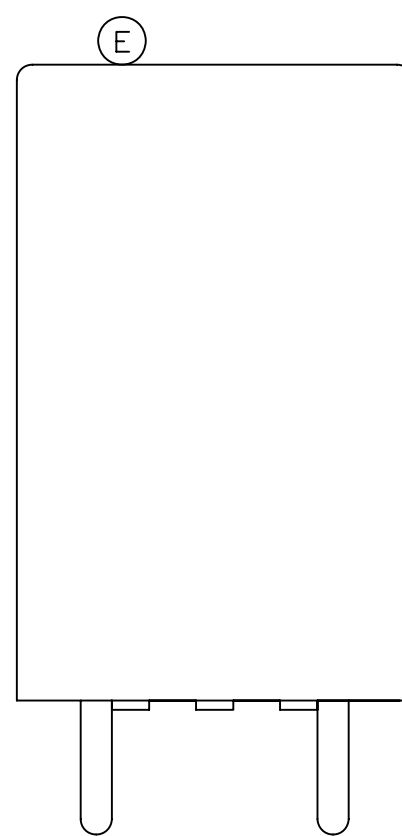
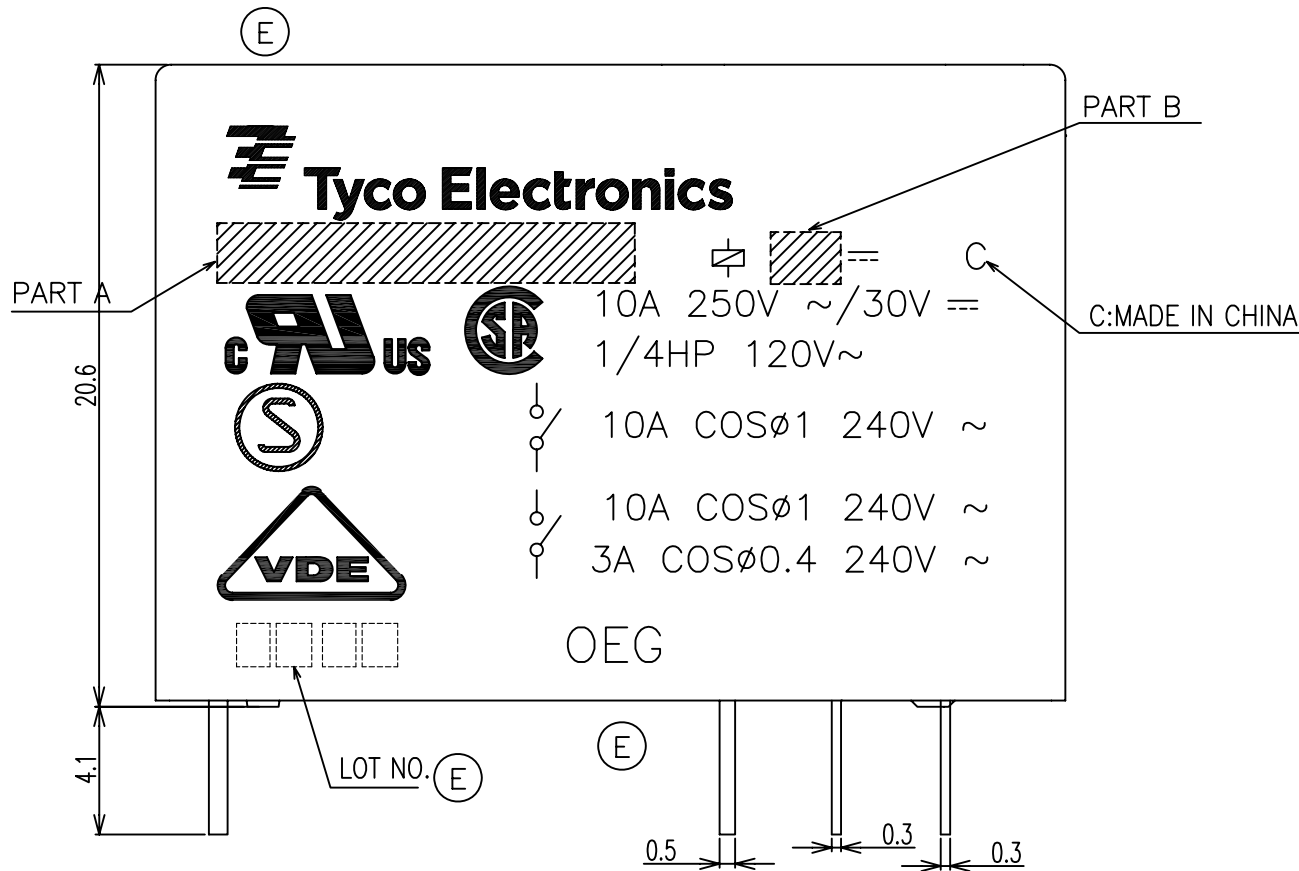
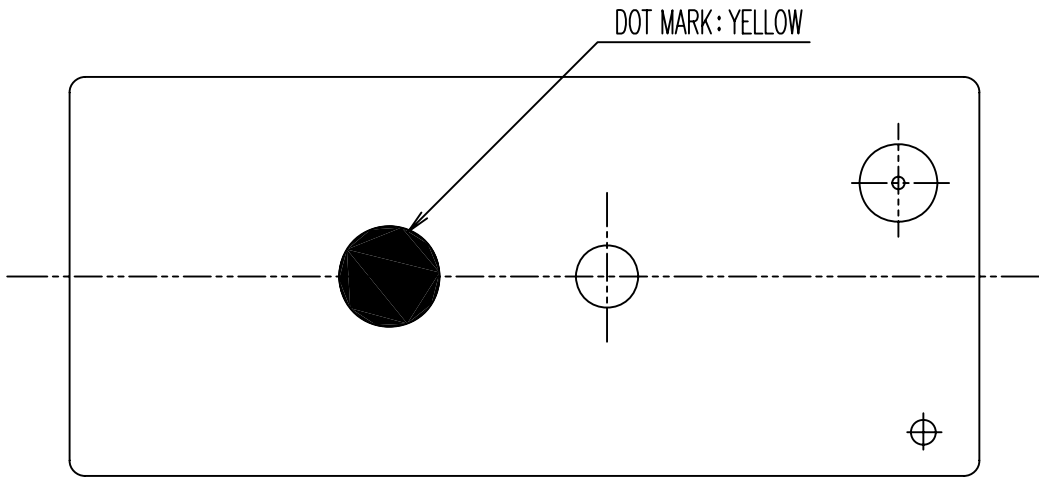

THIS DRAWING IS A CONTROLLED DOCUMENT FOR TYCO ELECTRONICS CORPORATION IT IS SUBJECT TO CHANGE AND THE CONTROLLING ENGINEERING ORGANIZATION SHOULD BE CONTACTED FOR THE LATEST REVISION.

DIMENSIONS: mm	TOLERANCES UNLESS OTHERWISE SPECIFIED:
	0 PLC ±
	1 PLC ±
	2 PLC ±
	3 PLC ±
	4 PLC ±
	ANGLES ±
MATERIAL	FINISH
-	-

DWN	K.Komuro	Tyco Electronics Corporation Shenzhen, China			
CHK	K.Komuro				
APVD	K.Komuro	NAME			
PRODUCT SPEC	-	OMI-SH-D/L SPEC,094			
APPLICATION SPEC	-	SIZE	CAGE CODE	DRAWING NO	RESTRICTED TO
WEIGHT	-	A3	00779	1393171-1	-
CUSTOMER DRAWING			SCALE	SHEET	REV
			4:1	1 OF 2	E

THIS DRAWING IS UNPUBLISHED. RELEASED FOR PUBLICATION
 © COPYRIGHT BY TYCO ELECTRONICS CORPORATION. ALL RIGHTS RESERVED.

LOC HB	DIST	REVISIONS						
		P	LTR	DESCRIPTION	ECN	DATE	DWN	APVD

NOTES:
 1.-SH-:WASHABLE TYPE
 2.LOT NO. SYSTEM AS FOLLOWING:

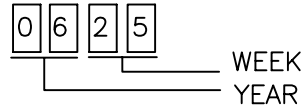

3.GENERAL TOLERANCE AS FOLLOWING:

TOLERANCE	
0~0.99mm	±0.1
1mm~2.99mm	±0.2
3mm MIN.	±0.3

④ 4.TERMINAL DIMENSION IS NOT INCLUDING SOLDER TIP.

1-1419122-2	OMI-SH-124L	24V	OMI-SH-124L	c
1419122-4	OMI-SH-112L	12V	OMI-SH-112L	b
1393171-1	OMI-SH-112D	12V	OMI-SH-112D	a
TE PART NO	DESCRIPTION	PART B	PART A	ITEM

RELAY TYPE

		UV RESIN	UV SEAL	17	
		EPOXY RESIN	SEAL	16	
UL94 V-0		PBT	CASE	15	
CLASS E		UEW	MAGNETIC WIRE	14	
UL94 V-0		PET	BASE	13	
UL94 V-0		PBT	BOBBIN	12	
	SOLDER DIP	CP WIRE	COIL TERMINAL	11	
UL94 V-0		PPS	CARD	10	
		Ag ALLOY	MOVABLE CONTACT	9	
		Ag ALLOY	STATIONARY CONTACT	8	
		Cu ALLOY	HINGE SPRING	7	
	SOLDER DIP	Cu ALLOY	B TERMINAL	6	
	SOLDER DIP	Cu ALLOY	M TERMINAL	5	
	SOLDER DIP	Cu ALLOY	MOVABLE SPRING	4	
		STEEL	CORE	3	
		STEEL	ARMATURE	2	
		STEEL	YOKE	1	
	INCOMBUSTIBILITY	TREATMENT	MATERIAL	DESCRIPTION	ITEM

THIS DRAWING IS A CONTROLLED DOCUMENT FOR TYCO ELECTRONICS CORPORATION IT IS SUBJECT TO CHANGE AND THE CONTROLLING ENGINEERING ORGANIZATION SHOULD BE CONTACTED FOR THE LATEST REVISION.		DWN	Tyco Electronics Corporation Shenzhen,China		
DIMENSIONS: mm		CHK			
		APVD	NAME OMI-SH-D/L SPEC,094		
TOLERANCES UNLESS OTHERWISE SPECIFIED: 0 PLC ± 1 PLC ± 2 PLC ± 3 PLC ± 4 PLC ± ANGLES ±		PRODUCT SPEC	SIZE A3		
MATERIAL		APPLICATION SPEC	CAGE CODE	DRAWING NO	RESTRICTED TO
FINISH		WEIGHT	00779	1393171-1	-
		CUSTOMER DRAWING	SCALE 4:1		SHEET 2 OF 2
					REV E