

ISS.	AMEND	DATE
1	1st DRAWN	29/08/06
2	BORDER+RATINGS	03/09/10
3	STAND OFF DIMS ADD	13/12/11
4	SUPPORT PIN ADD	30/04/13

VARIANTS	
PART NO.	COLOUR
FCR7350B	BLACK
FCR7350R	RED
FCR7350G	GREEN
FCR7350L	BLUE
FCR7350Y	YELLOW

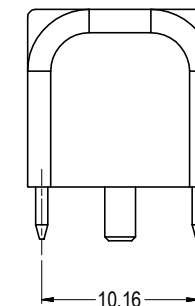

SEE FCR7350SA1 FOR COLOUR VARIANT

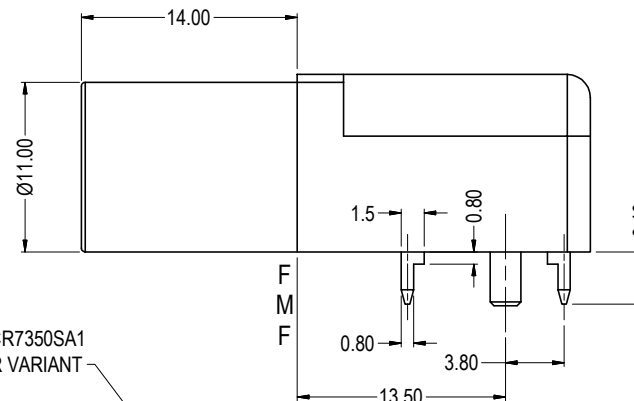
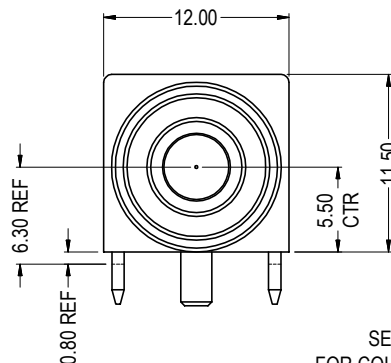
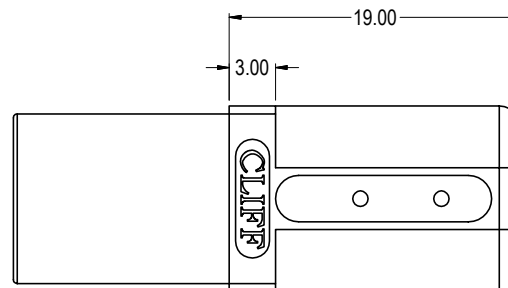
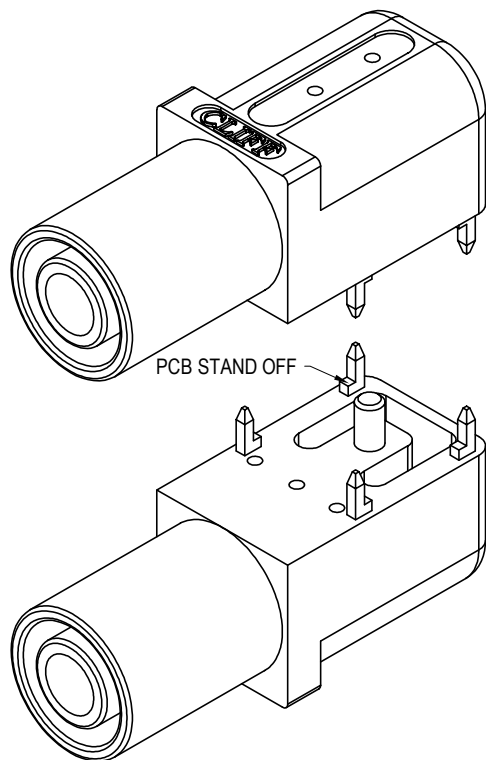
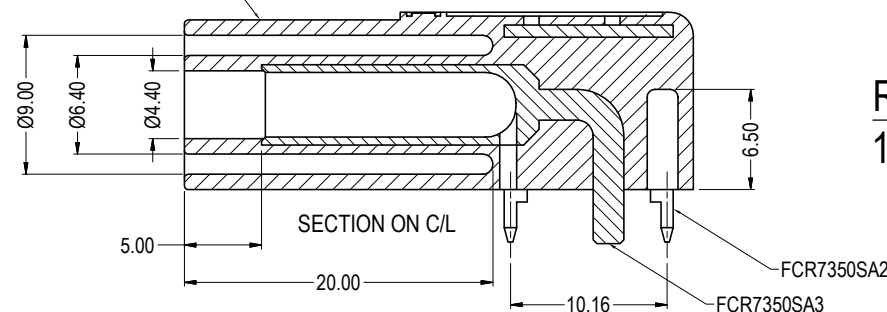
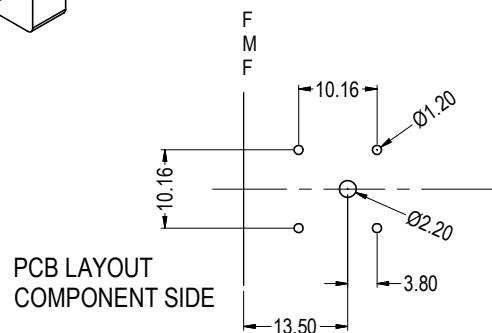

**RATED**  
1kV CAT III - 24A

### NOTES

- 1) PART TO BE INSERT MOULDED WITH FCR7350SA2 AND FCR7350SA3
- 2) PARTS TO BE MADE TO CAD FILE SUPPLIED
- 3) PARTS TO BE FREE FROM FLASH AND SINK
- 4) FEED POINT TO BE AGREED
- 5) LOGO AND RATING TO BE ON INSERTS

**RoHS**  
COMPLIANT

**TOLERANCE**  
NO DEC. PLACE ± 0.50  
1 DEC. PLACE ± 0.20  
2 DEC. PLACE ± 0.10  
HOLE Ø ± 0.10  
ANGLES ± 1/2°  
UNLESS OTHERWISE STATED

**Cliff Electronic Components Ltd.**

76 Holmethorpe Avenue, Holmethorpe Industrial Estate,  
Redhill, Surrey, RH1 2PF, England, UK

Tel: 01737-771375 Fax: 01737-766012 Website: www.cliffuk.co.uk

THE CONTENTS OF THIS DOCUMENT MUST NOT BE COPIED OR DISCLOSED TO A 3rd PARTY WITHOUT WRITTEN PERMISSION OF CLIFF UK. © 2006

DIMENSIONS IN MILLIMETERS UNLESS OTHERWISE STATED. WORK TO DIMENSIONS. REMOVE ALL BURRS. IF IN DOUBT ASK.

3rd ANGLE PROJECTION:

DO NOT SCALE

MATERIAL: NYLON 6 / BRASS

FINISH: AS MOULDED / GOLD PLATED

DRAWN: T.J.O.

APPROVED: D.P.J.

TITLE: S16N - PC (COLOUR)

DRWG. No. **FCR7350**

FORM: A4DRWGF