

THIS DRAWING IS UNPUBLISHED. RELEASED FOR PUBLICATION
 © COPYRIGHT - By - ALL RIGHTS RESERVED.

LOC		DIST		REVISIONS			
P	LTR	DESCRIPTION		DATE	DWN	APVD	
GP	00	L		REVISED PER ECO-13-005652	01APR2013	CJV	SLB

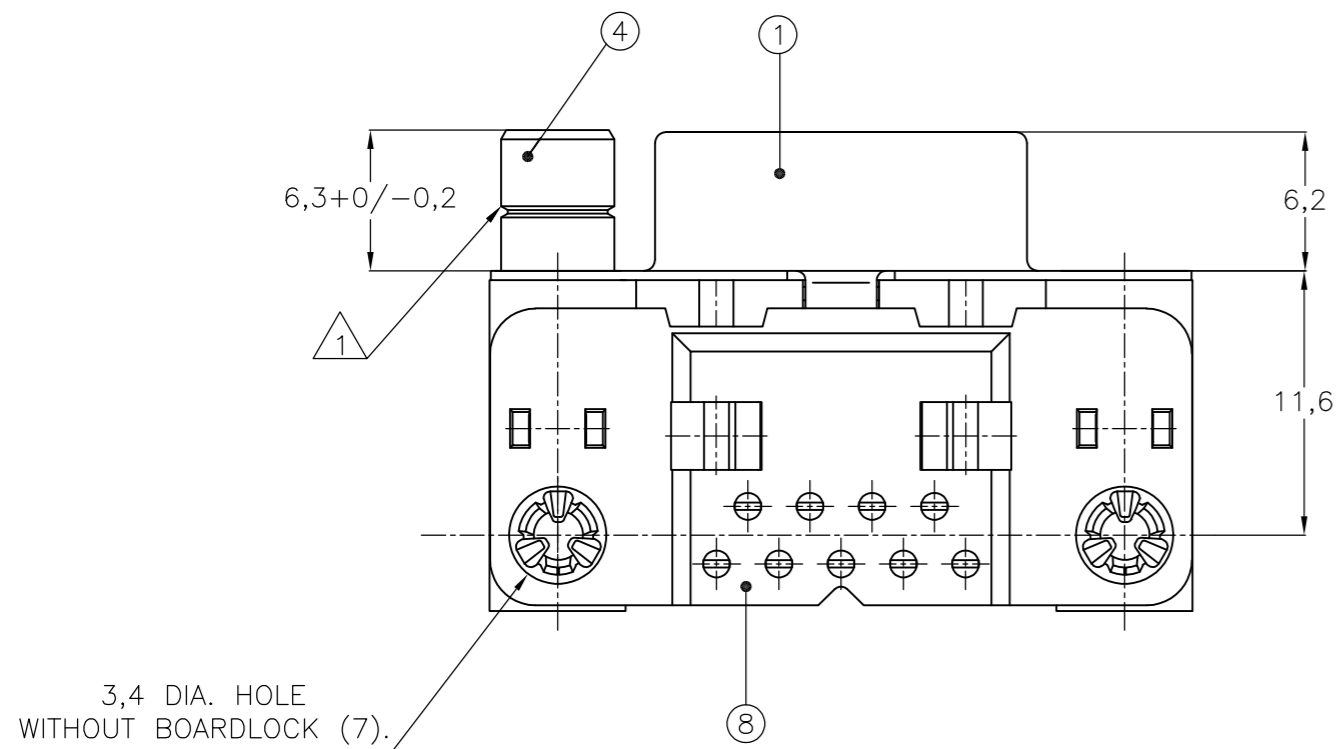
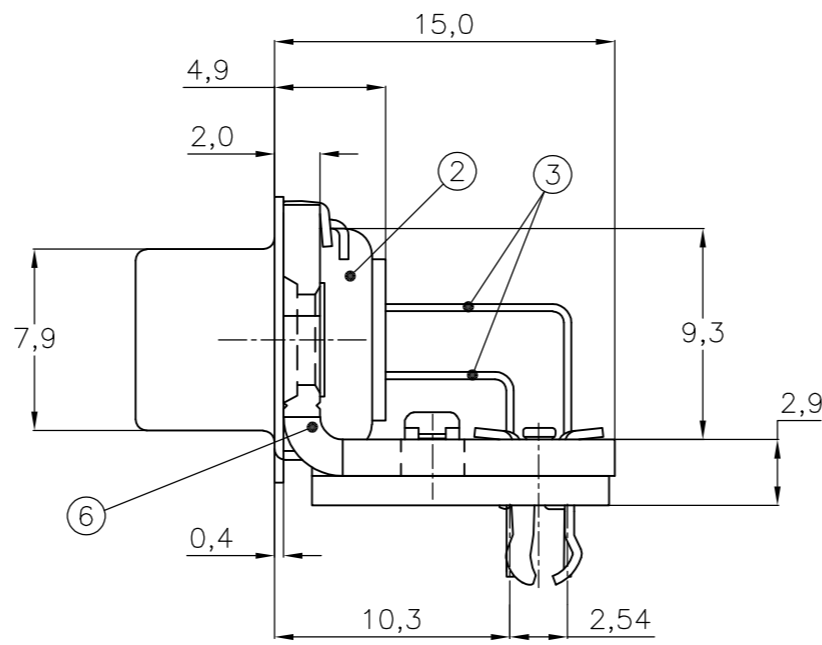
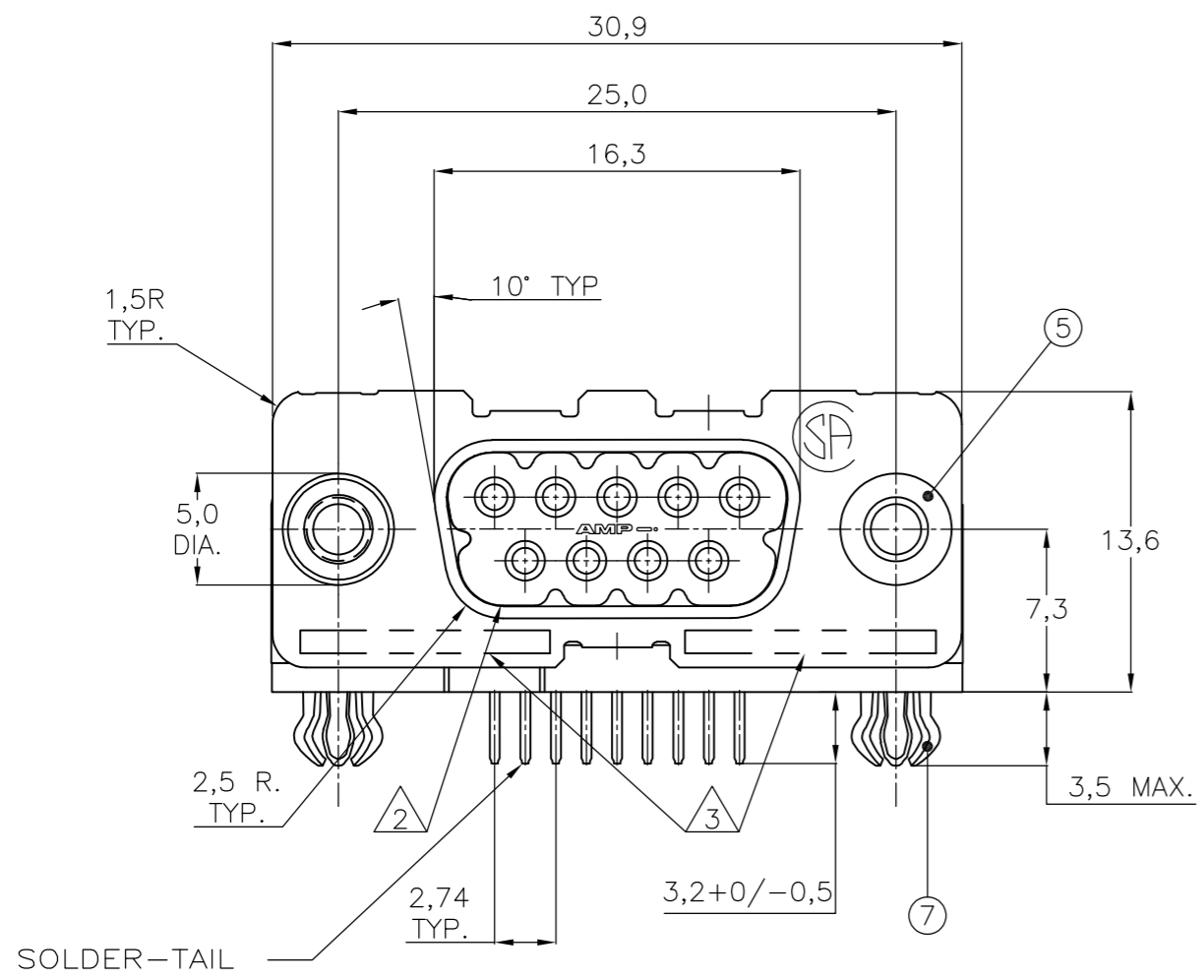

ACCESSORIES	ITEM NO.	DESCRIPTION OF ACCESSORY	QUANTITIES											
			1	2	3	4	5	6	7	8	9			
	5	BUSHING WITH THROUGH-HOLE 3,1 DIA.						2						
	5	BUSHING WITH INNER THREAD 4-40 UNC		2						2				
	5	BUSHING WITH INNER THREAD M3			2						2			
	4	FEMALE SCREWLOCK WITH 4-40 UNC					2						2	
	4	FEMALE SCREWLOCK WITH M3							2					2
	7	BOARDLOCK	2	2	2	2	2							

- ① GROOVE INDICATES VERSION WITH 4-40 UNC INNER THREAD; WITHOUT GROOVE INDICATES VERSION WITH M3 INNER THREAD.
- ② CAVITY IDENTIFICATION AT FRONT SIDE ONLY.
- ③ PART NUMBER AND DATE CODE.
- 4. AIR AND CREEPAGE DISTANCES ACCORDING TO DIN 41652.
- ⑤ CONTACT FINISH: GOLD FLASH OVER PALLADIUM NICKEL PLATE OR GOLD PLATE ON MATING SURFACES, TIN PLATE ON THE SOLDER-TAILS, NICKEL UNDERPLATE ON THE ENTIRE CONTACT. MATING SURFACE FINISH MEETS PERFORMANCE LEVEL 2 PER DIN 41652.

ITEM NO./MATERIAL :

- ① SHELL : BRIGHT TIN PLATED STEEL
- ② HOUSING : GLASS FILLED POLYESTER, COLOR : BLACK
- ③ CONTACTS : PHOSPHOR BRONZE (PLATING : SEE NOTES ABOVE)
- ④ FEMALE SCREWLOCK : TIN PLATED STEEL (INNER THREAD 4-40 UNC OR M3)
- ⑤ BUSHING : TIN PLATED STEEL (INNER THREAD 4-40 UNC OR M3 OR 3,1 DIA THROUGH-HOLE)
- ⑥ BRACKET : TIN PLATED STEEL
- ⑦ BOARDLOCK : TIN PLATED PHOSPHOR BRONZE
- ⑧ POST ALIGNMENT PLATE : GLASS FILLED NYLON COLOR : BLACK

RECOMMENDED P.C. BOARD HOLE-LAYOUT

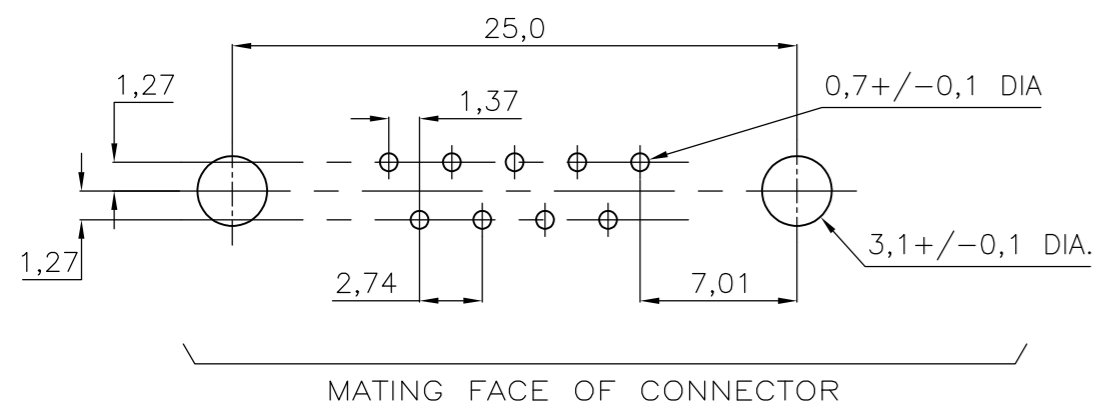

THIS DRAWING IS A CONTROLLED DOCUMENT. DIMENSIONING AND TOLERANCING PER ASME Y14.5M-2009		DWN D. KESSLER 14JAN99	TE Connectivity	
DIMENSIONS: mm		CHK W. SOOMERS		
TOLERANCES UNLESS OTHERWISE SPECIFIED:		APVD -	HD-20 SIZE 1 RIGHT ANGLE RECEPTACLE HEADER; MARK II+	
0 PLC ± -		PRODUCT SPEC -	SIZE A2	CAGE CODE 00779
1 PLC ± 0.3		APPLICATION SPEC -	DRAWING NO C=106505	RESTRICTED TO -
2 PLC ± 0.15		WEIGHT -	SCALE NTS	SHEET 1 OF 1
3 PLC ± -		CUSTOMER DRAWING	REV L	
4 PLC ± -				
ANGLES ± 2°				
FINISH -				