

### TOP VIEW OF ASSEMBLY

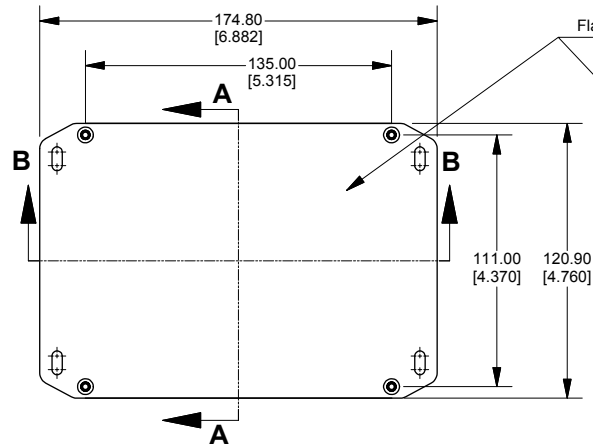

### SECTION A-A END VIEW OF ASSEMBLY

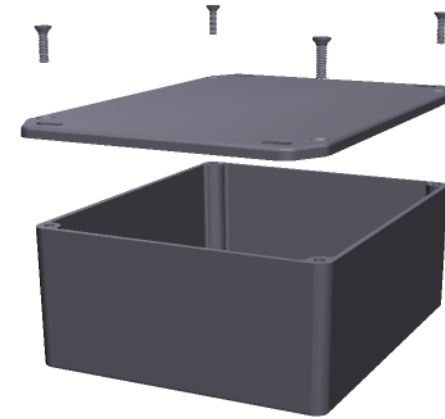
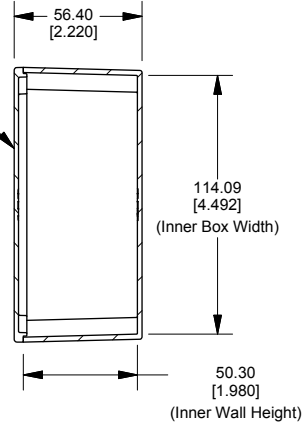

### SECTION B-B SIDE VIEW OF ASSEMBLY

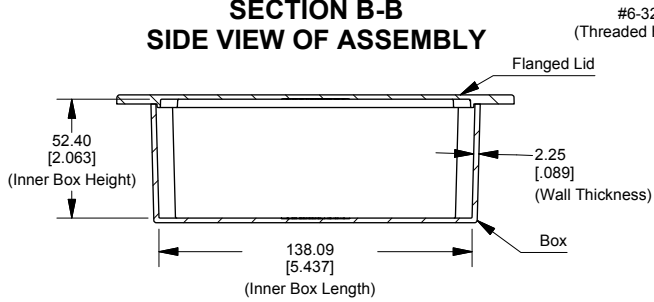

### TOP VIEW LOOKING INSIDE BOX

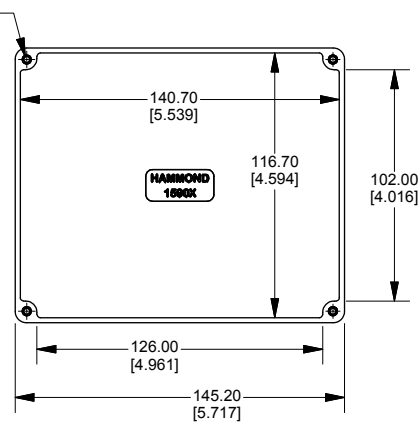

Enclosures can be Factory Modified ( Milling, Drilling, Printing etc.)  
 Contact Factory [mjm@hammondmfg.com](mailto:mjm@hammondmfg.com) for quotes  
 Solid models of this enclosure available in STEP or IGES.

NOTE	
Purchased assembly includes box, lid and 4 cover screws.	
Box and lid are made from Diecast Aluminum Alloy.	
Silicone Gasket supplied with liquid resistant enclosure.	

PART NUMBERS	
1590XFL Enclosure	
Natural Finish Enclosure	1590XFL
Black Textured Enclosure	1590XFLBK
1590XFL Liquid Resistant Enclosure (Silicone Gasket)	
Natural Finish Enclosure	1590WXFL
Black Textured Enclosure	1590WXFLBK
ACCESSORIES	
Recommended Torque: 75 ozf.in / 55 cN.m	
Liquid Resistant Cover Screws	
Stainless Steel Cover Screws (Pkg 100) [6-32 x 1/2" With O-Ring]	1590WMS100
Black Stainless Steel Cover Screws (Pkg 100) [6-32 x 1/2" With O-Ring]	1590WMS100BK
Standard Cover Screws	
Plated Cover Screws (Pkg 100) [6-32 x 1/2"]	1590MS100
Black Cover Screws (Pkg 100) [6-32 x 1/2"]	1590MS100BK

### FLANGED LID

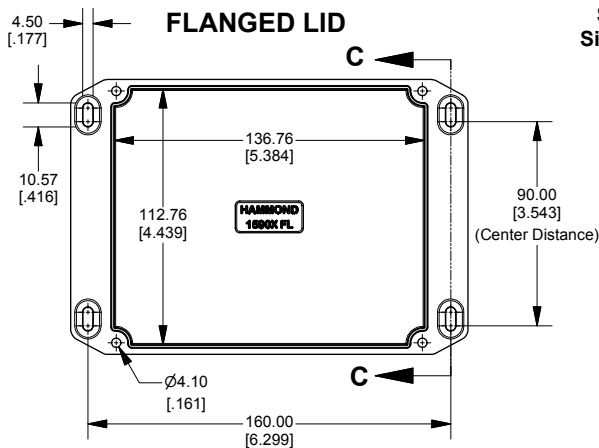

### SECTION C-C Side View of Slot

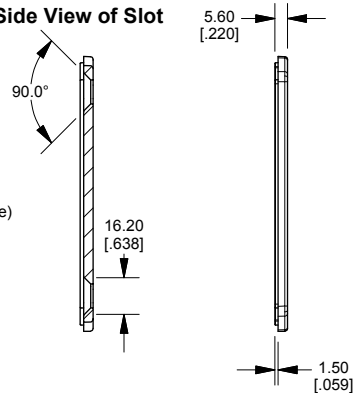

Dimensions:  
mm  
[inches]

**HAMMOND  
MANUFACTURING™**

**1590XFL**

[www.hammondmfg.com](http://www.hammondmfg.com)