

DO NOT SCALE FROM THIS PRINT

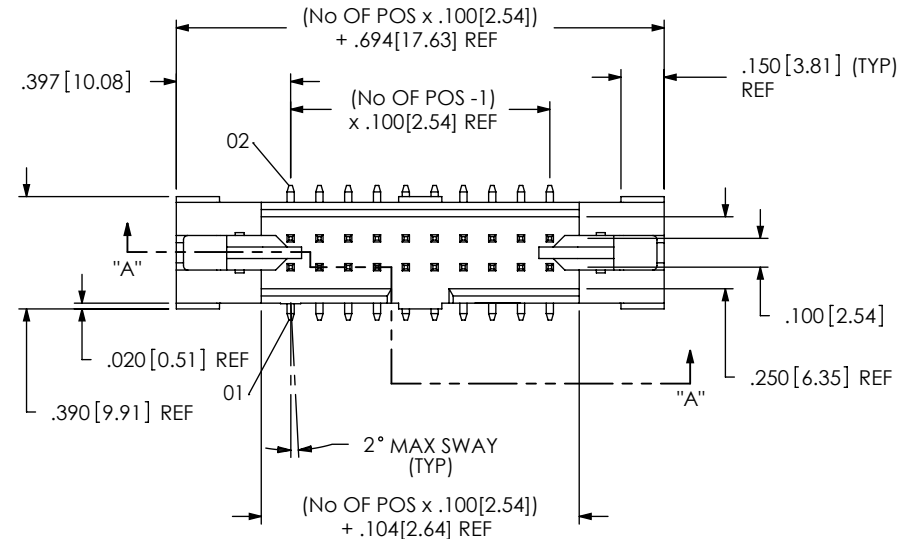

EJH-1XX-XX-XX-D-XX-XX-XX

No OF POSITIONS
-05 THRU -25

LEAD STYLE
-01: STANDARD (USE EJH-XX-D)
-02: EXTENDED (SEE FIG 11, SHEET 4) (USE EJH-XX-D-EXT & EHA-03-EXT)

PLATING SPECIFICATION
-S: SELECTIVE GOLD (USE T-1S6X-XX-S-X)
-F: FLASH SELECTIVE GOLD (USE T-1S6X-XX-F-X)
-SM: SELECTIVE HEAVY GOLD (USE T-1S6X-XX-S-X)
-FM: FLASH SELECTIVE GOLD, MATTE TIN TAIL (USE T-1S6X-XX-F-X)
-L: LIGHT SELECTIVE GOLD MATTE TIN TAIL (USE T-1S6X-XX-L-X)

OPTION
-LC: LOCKING CLIP (FOR -SM ONLY) (SEE NOTE 10)
-P: PICK & PLACE PAD (FOR -SM ONLY) (USE PPP-50, SEE FIGURE 6, SHEET 3)
-K: POLYAMIDE FILM (SEE FIG 3, SHEET 3) (USE K-850-650)
-TR: TAPE & REEL PACKAGING (SEE FIG 7, SHEET 3) (FOR -SM-P, & -SM-K ONLY) (NOT AVAILABLE ON -SM-LC) (NOT AVAILABLE ON -25 POSITION)

POLARIZED OPTION
-XX = PIN OMITED

TAIL OPTION
-SM: SURFACE MOUNT (SEE FIG. 1)
-TH: THROUGH HOLE (SEE FIG 8, SHEET 2)
-RA: RIGHT ANGLE (SEE FIG 9, SHEET 2)

ROW SPECIFICATION
-D: DOUBLE

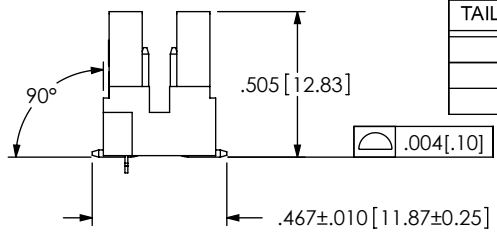
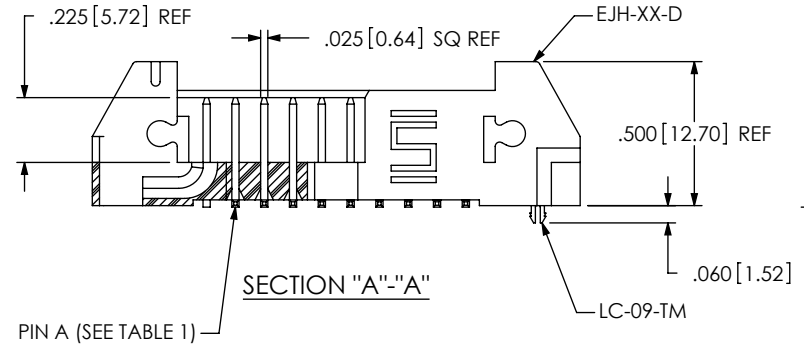

TAIL OPTION	PIN A	PIN B
-SM	T-1S6-08-XX-2	--
-TH	T-1S6-22-XX-2	--
-RA	T-1S64-01-XX	T-1S64-02-XX

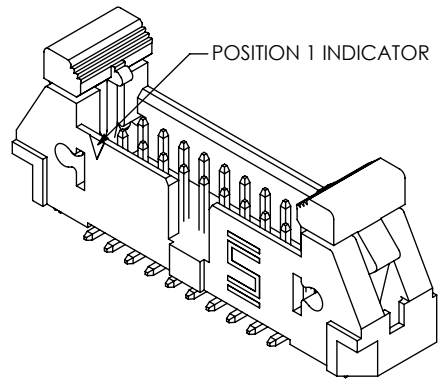
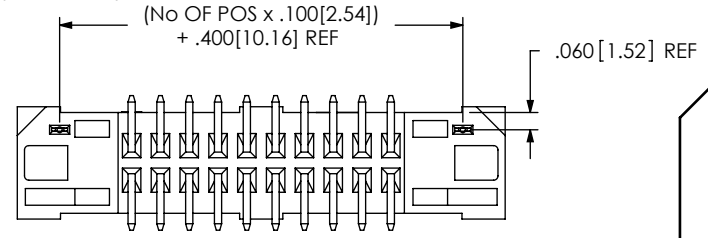
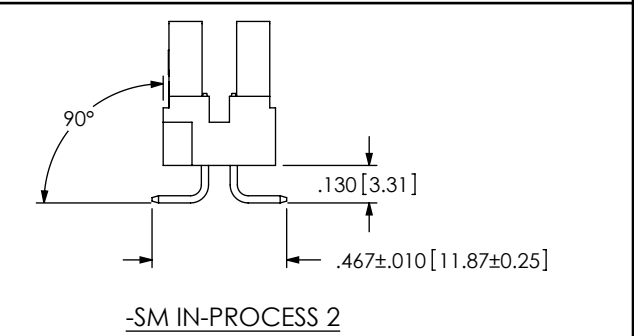
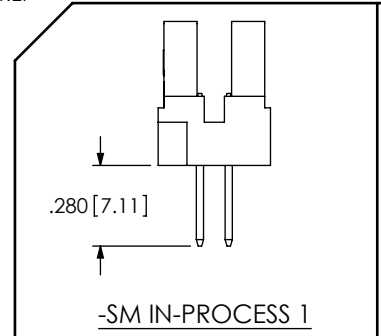

FIG 1
EJH-110-01-X-D-SM-LC SHOWN

NOTES:

- ⊕ REPRESENTS A CRITICAL DIMENSION.
- COPLANARITY TO BE: .004 MAX FOR POSITIONS -05 THRU -10
.006 MAX FOR POSITIONS -15 THRU -25
- BURR ALLOWANCE: .0015 MAX.
- MINIMUM PUSHOUT FORCE: 1 LB MIN.
- MAXIMUM ALLOWABLE BOW: .002 INCH/INCH AFTER ASSEMBLY.
- PARTS TO BE TUBED WITH EJECTOR ARMS IN THE UP POSITION AS SHOWN.
- REPRESS TO DIMENSION SHOWN.
- NOTE DELETED.
- MEASURE FROM THE TIPS OF THE TERMINALS.
- DUE TO THE HIGH AMOUNT OF INSERTION FORCE NEEDED, THE -LC OPTION IS NOT COMPATIBLE WITH AUTO PLACEMENT. SAMTEC RECOMMENDS MANUAL PLACEMENT FOR ALL ASSEMBLIES WITH THE -LC OPTION.



UNLESS OTHERWISE SPECIFIED, DIMENSIONS ARE IN INCHES. TOLERANCES ARE: DECIMALS ANGLES .XX: ±.01 [.3] .XXX: ±.005 [.13] .XXXX: ±.0020 [.051]	PROPRIETARY NOTE THIS DOCUMENT CONTAINS INFORMATION CONFIDENTIAL AND PROPRIETARY TO SAMTEC, INC. AND SHALL NOT BE REPRODUCED OR TRANSFERRED TO OTHER DOCUMENTS OR DISCLOSED TO OTHERS OR USED FOR ANY PURPOSE OTHER THAN THAT WHICH IT WAS OBTAINED WITHOUT THE EXPRESSED WRITTEN CONSENT OF SAMTEC, INC.	samtec 520 PARK EAST BLVD, NEW ALBANY, IN 47150 PHONE: 812-944-6733 FAX: 812-948-5047 e-Mail: info@SAMTEC.com code: 55322
MATERIAL: DO NOT SCALE DRAWING -01 INSULATOR: VECTRA E130i, COLOR: BLACK -02 INSULATOR COLOR: NATURAL TERMINAL: PHOS BRONZE 510 3/4 HARD	SHEET SCALE: 1:0.6666666666666667	DESCRIPTION: .100 x .100 EJECTOR HEADER ASSEMBLY
DWG. NO. EJH-1XX-XX-XX-D-XX-XX-XX		BY: ERIC M. 09/19/01 SHEET 1 OF 4

F:\DWG\MISC\MKTG\EJH-1XX-XX-XX-D-XX-XX-XX-MKT.SLDDRW

FIG 8
EJH-110-01-X-D-TH SHOWN
[DIFFERENT AS SHOWN, OTHERWISE SAME AS FIG 1]

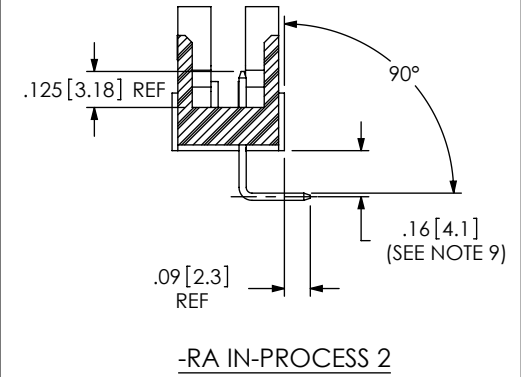
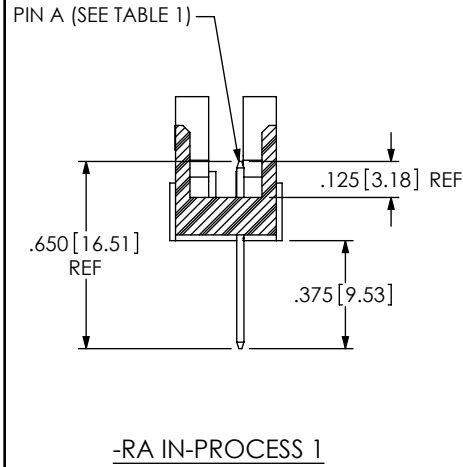
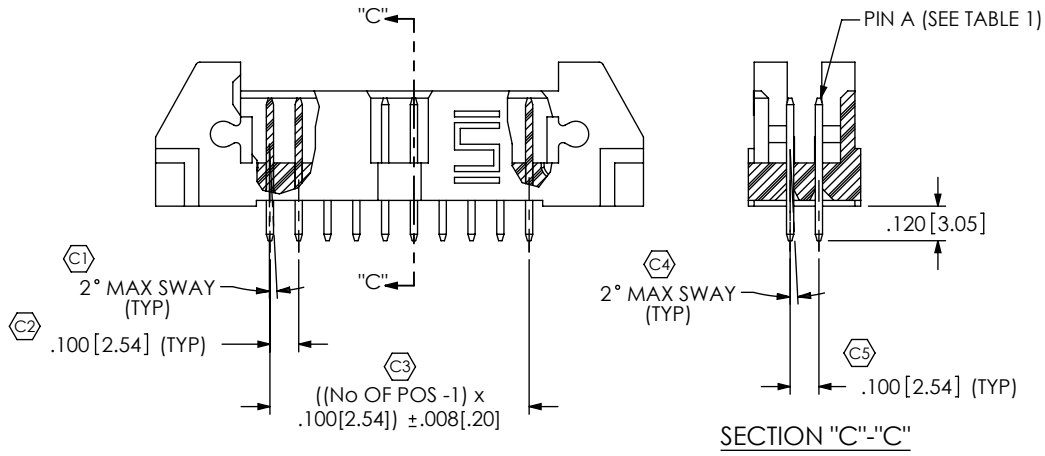
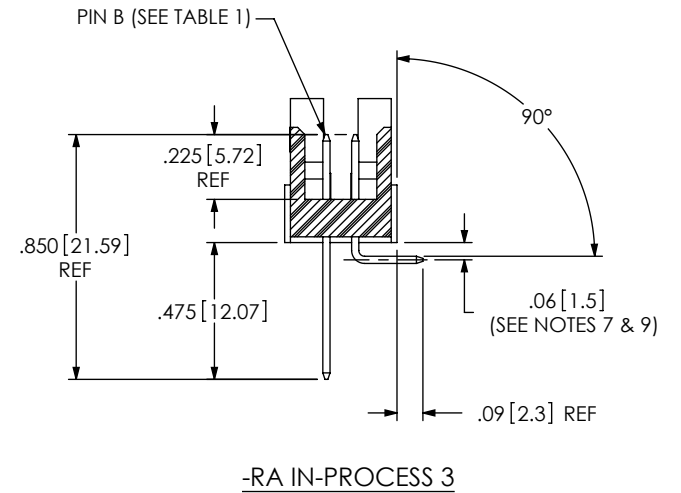
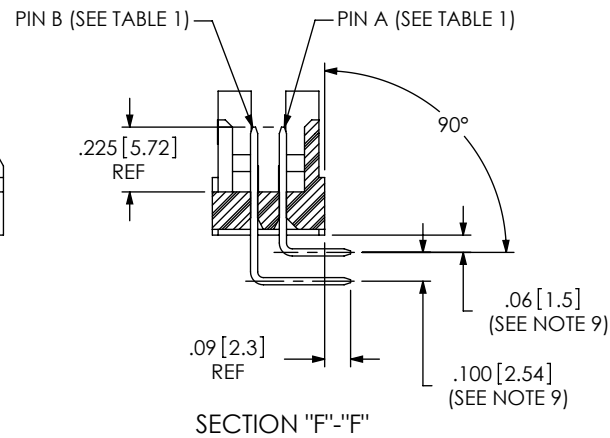
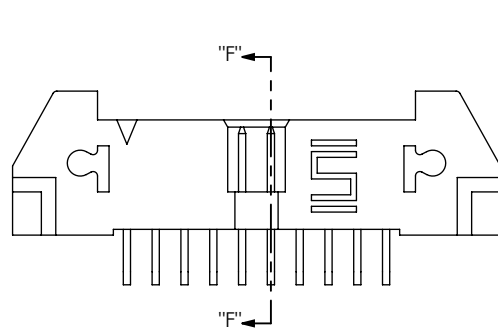
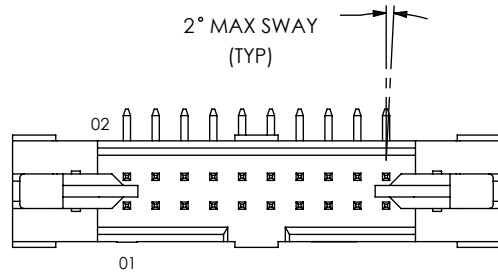

FIG 9
EJH-110-01-X-D-RA SHOWN
[DIFFERENT AS SHOWN, OTHERWISE SAME AS FIG 1]



PROPRIETARY NOTE
THIS DOCUMENT CONTAINS INFORMATION
CONFIDENTIAL AND PROPRIETARY TO
SAMTEC, INC. AND SHALL NOT BE REPRODUCED
OR TRANSFERRED TO OTHER DOCUMENTS OR
DISCLOSED TO OTHERS OR USED FOR ANY
PURPOSE OTHER THAN THAT WHICH IT WAS
OBTAINED WITHOUT THE EXPRESSED WRITTEN
CONSENT OF SAMTEC, INC.

DO NOT SCALE DRAWING

SHEET SCALE: 1.5:1

samtec

520 PARK EAST BLVD, NEW ALBANY, IN 47150
PHONE: 812-944-6733 FAX: 812-948-5047
e-Mail: info@SAMTEC.com code: 55322

DESCRIPTION:
.100 x .100 EJECTOR HEADER ASSEMBLY

DWG. NO.
EJH-1XX-XX-XX-D-XX-XX-XX

BY: ERIC M. 09/19/01 SHEET 2 OF 4

FIG 2
ARM ASSEMBLY & ROTATION

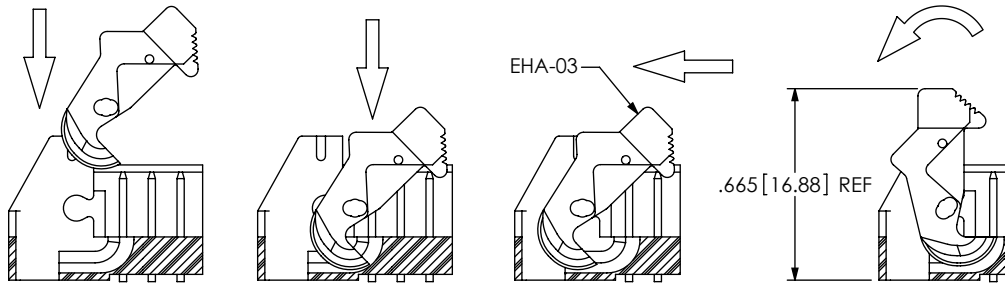
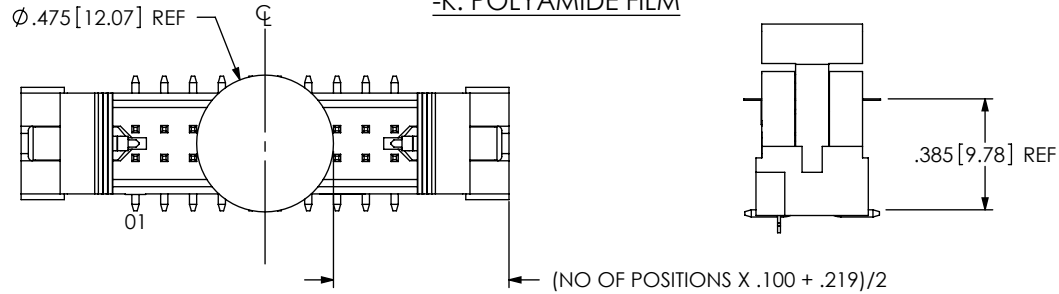

FIG 3
-K: POLYAMIDE FILM



PACKAGING TUBE VIEWS

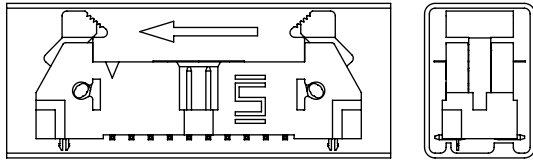

FIG 4
SURFACE MOUNT
(SEE NOTE 6)

TUBE: PT-1-24-01-121
PLUG: TP-13

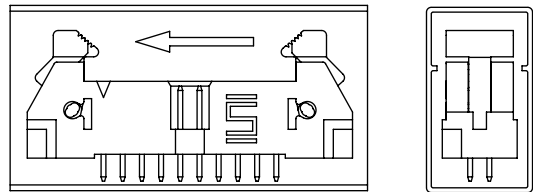

FIG 5
THROUGH HOLE
(SEE NOTE 6)

TUBE: PT-1-24-02-74
PLUG: TP-26

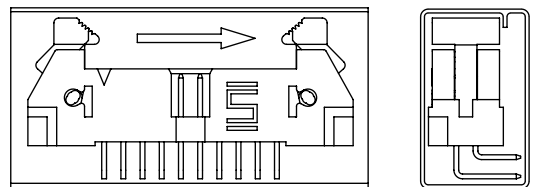
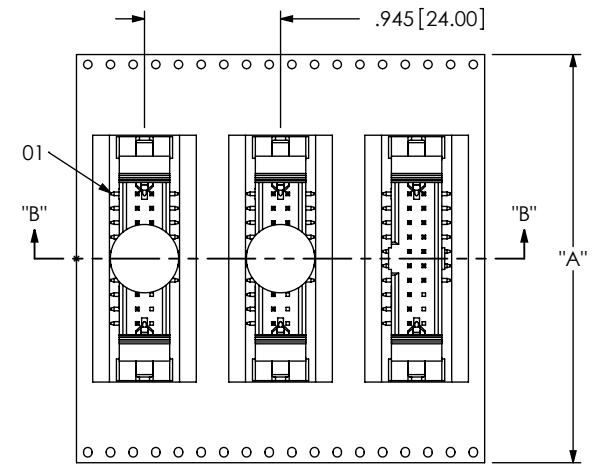
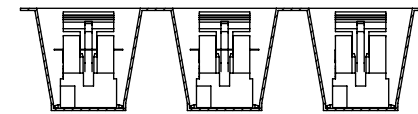

FIG 10
RIGHT ANGLE
(SEE NOTE 6)

TUBE: PT-1-24-01-131
PLUG: TP-26



USER DIRECTION OF UN-REELING →
POCKET NOT DETAILED



SECTION "B"- "B"
SCALE 0.75 : 1

TABLE 2	
No OF POS	"A"
-05	2.205 [56.00]
-07	2.205 [56.00]
-10	2.835 [72.00]
-15	3.465 [88.00]
-20	3.465 [88.00]

FIG 7
-TR TAPE & REEL PACKAGING

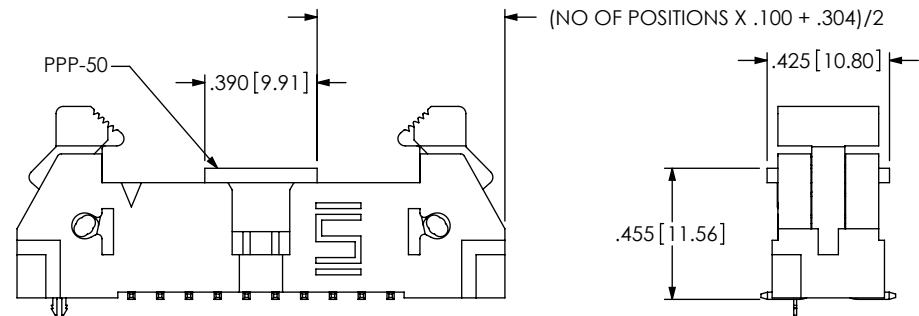

FIG. 6
-P: PICK & PLACE PAD

PROPRIETARY NOTE
THIS DOCUMENT CONTAINS INFORMATION
CONFIDENTIAL AND PROPRIETARY TO
SAMTEC, INC. AND SHALL NOT BE REPRODUCED
OR TRANSFERRED TO OTHER DOCUMENTS OR
DISCLOSED TO OTHERS OR USED FOR ANY
PURPOSE OTHER THAN THAT WHICH IT WAS
OBTAINED WITHOUT THE EXPRESSED WRITTEN
CONSENT OF SAMTEC, INC.

DO NOT SCALE DRAWING

SHEET SCALE: 1:0.666667

samtec

520 PARK EAST BLVD, NEW ALBANY, IN 47150
PHONE: 812-944-6733 FAX: 812-948-5047
e-Mail: info@SAMTEC.com code: 55322

DESCRIPTION:
.100 x .100 EJECTOR HEADER ASSEMBLY

DWG. NO.
EJH-1XX-XX-XX-D-XX-XX-XX

BY: ERIC M. 09/19/01 SHEET 3 OF 4

FIG 11
 -02 LEAD STYLE
 (SAME AS FIG 1, UNLESS OTHERWISE STATED)
 (EJH-125-02-X-D-SM-LC SHOWN)

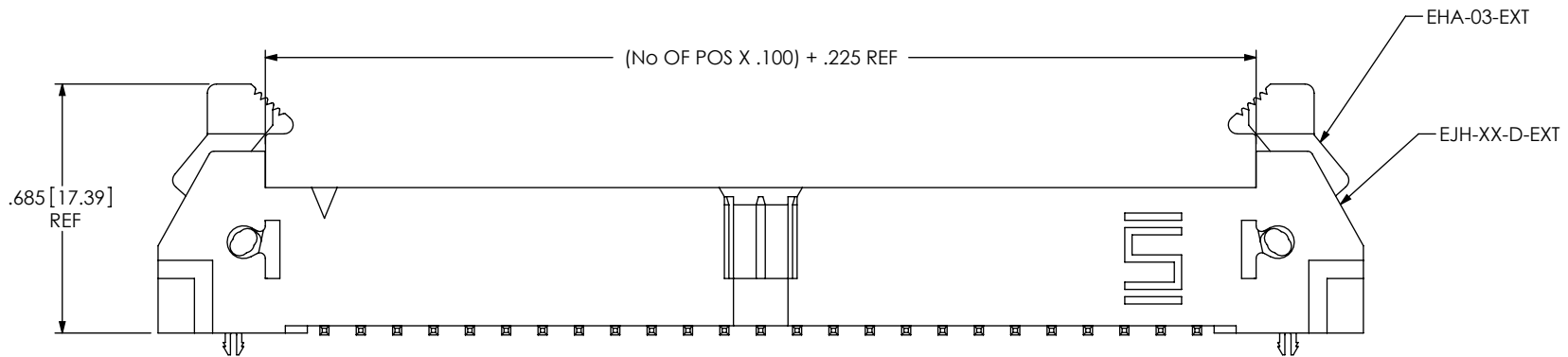
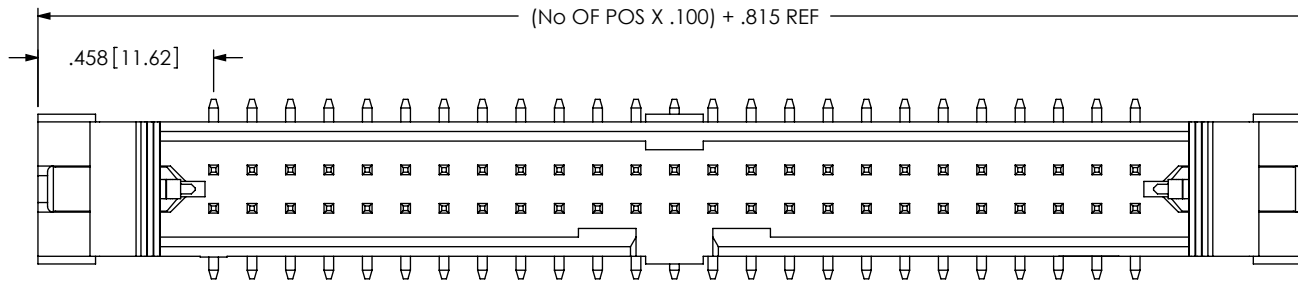

<p>PROPRIETARY NOTE THIS DOCUMENT CONTAINS INFORMATION CONFIDENTIAL AND PROPRIETARY TO SAMTEC, INC. AND SHALL NOT BE REPRODUCED OR TRANSFERRED TO OTHER DOCUMENTS OR DISCLOSED TO OTHERS OR USED FOR ANY PURPOSE OTHER THAN THAT WHICH IT WAS OBTAINED WITHOUT THE EXPRESSED WRITTEN CONSENT OF SAMTEC, INC.</p> <p>DO NOT SCALE DRAWING</p> <p>SHEET SCALE: 2:1</p>		
	<p>520 PARK EAST BLVD, NEW ALBANY, IN 47150 PHONE: 812-944-6733 FAX: 812-948-5047 e-Mail: info@SAMTEC.com code: 55322</p>	
	<p>DESCRIPTION: .100 x .100 EJECTOR HEADER ASSEMBLY</p>	
	<p>DWG. NO. EJH-1XX-XX-XX-D-XX-XX-XX</p>	
	<p>BY: ERIC M. 09/19/01</p>	<p>SHEET 4 OF 4</p>