

DESCRIPTION	QTY	MATERIAL	FINISH / COLOUR
COVER	1	LCP	BLACK
HOUSING	1	LCP	BLACK
CENTRE PIN	1	BRASS	NICKEL PLATED
CONTACT 1	1	BRASS	TIN PLATED
CONTACT 2	1	BRASS	TIN PLATED
CONTACT 3	1	PHOS BRONZE	TIN PLATED

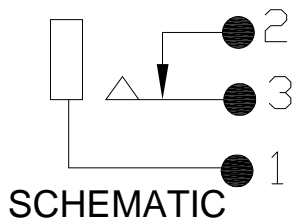

ISS.	AMEND	DATE
1	ISSUED	16/10/12
2	ERR WAS 1000x/REEL	07/08/13

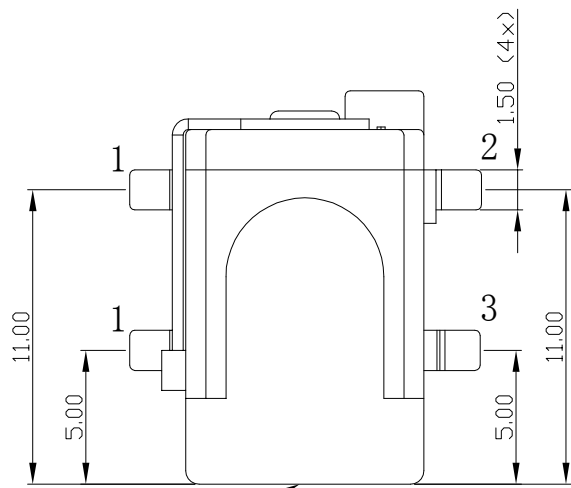

FRONT FACE

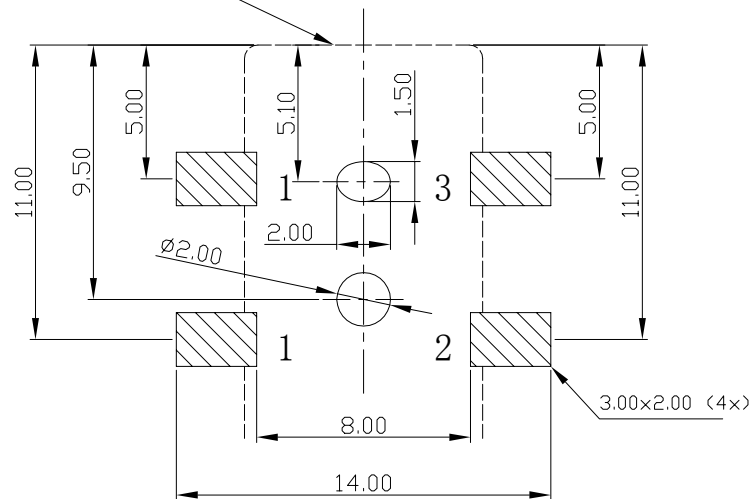

PCB LAYOUT
BOTTOM VIEW

FRONT FACE

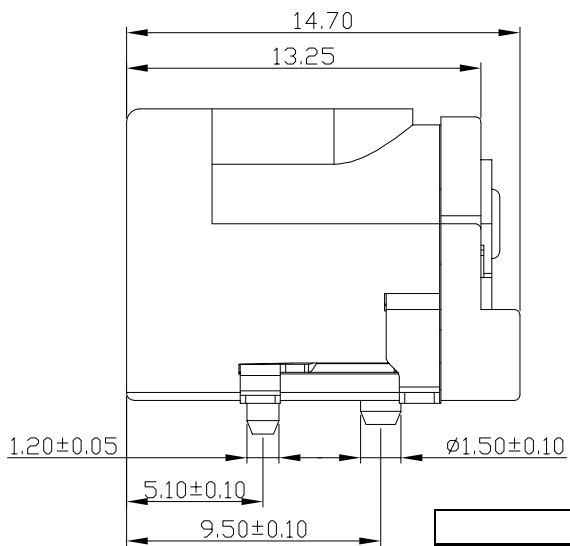
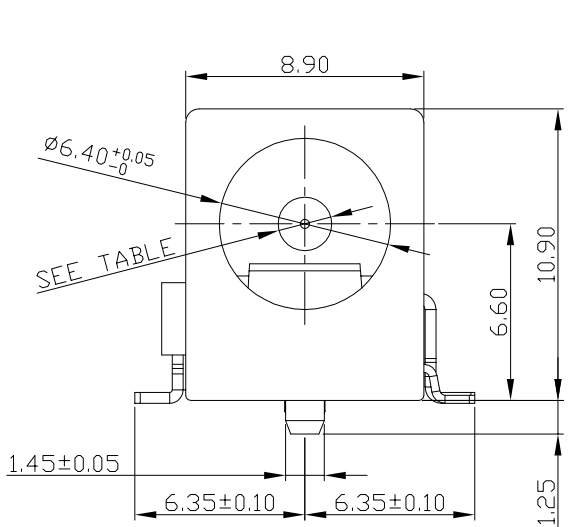

INSERTION / WITHDRAWAL FORCE: 0.3-2 kgf
 CONTACT RESISTANCE (4 TERMINAL METHOD 1KHz @ <100mA)
 INITIAL PLUG / CONTACT <50mΩ
 CONTACT / SHUNT <30mΩ
 AFTER LIFE TEST PLUG / CONTACT <100mΩ
 CONTACT / SHUNT <60mΩ
 ELECTRICAL RATING 2A / 12V

VARIANTS

PART No.	DESCRIPTION	PIN Ø	SUPPLIED
FC68148S	SMD DC10-AS	Ø2.1	BAGGED / LOOSE
FC68149S	SMD DC10-BS	Ø2.5	BAGGED / LOOSE
FC68148ST	SMDT DC10-AS	Ø2.1	TAPED 250x PER REEL
FC68149ST	SMDT DC10-BS	Ø2.5	TAPED 250x PER REEL

RoHS
COMPLIANT

TOLERANCE
 NO DEC. PLACE ± 0.50
 1 DEC. PLACE ± 0.30
 2 DEC. PLACE ± 0.15
 HOLE Ø ± 0.10
 ANGLES ± 2°
 UNLESS OTHERWISE STATED

Cliff Electronic Components Ltd.

76 Holmehorpe Avenue, Holmehorpe Industrial Estate,
Redhill, Surrey, RH1 2PF, England, UK
Tel: 01737-771375 Fax: 01737-766012 Website: www.cliffuk.co.uk

DIMENSIONS IN MILLIMETERS UNLESS OTHERWISE STATED. WORK TO DIMENSIONS. REMOVE ALL BURRS. IF IN DOUBT ASK.

3rd ANGLE PROJECTION:

DO NOT SCALE

MATERIAL: SEE TABLE

TITLE: SMD SOCKET DC-10AS 2.1mm + DC-10BS 2.5mm

FINISH: CLEAN

DRWG. No. **FC68148S**

THE CONTENTS OF THIS DOCUMENT MUST NOT BE COPIED OR DISCLOSED TO A 3rd PARTY WITHOUT WRITTEN PERMISSION OF CLIFF UK. © 2012

DRAWN: T.J.O.

APPROVED: D.P.J.

FORM: A4DRWGH