

PART NO.

DTRNMS 306 01

REVISIONS

ECN #	REV	DESCRIPTION	DRAWN	DATE	CHECKD	DATE	APPRVD	DATE
-	1.0	RELEASED	SN	23/03/15	ER	23/03/15	ER	23/03/15

**RoHS
Compliant**

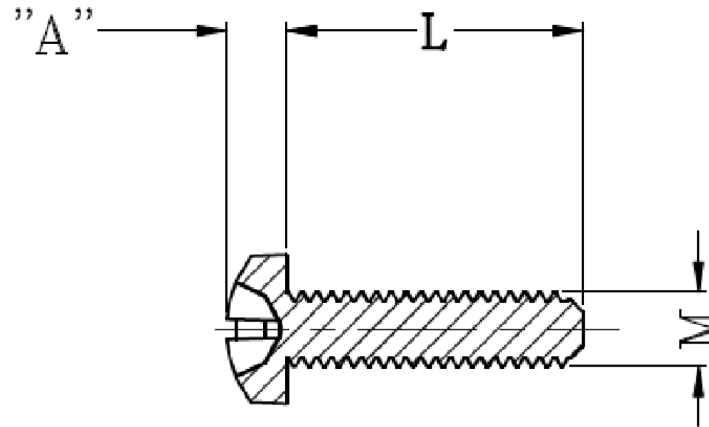
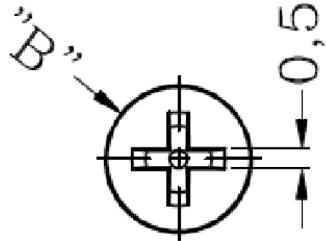

Specifications:

Material : Nylon 66
Colour : Natural

Dimensions : Millimetres

Part Number Table

Description	L	A	B	Thread	Part Number
Set Screw, Nylon, Metric, PK100	6.4mm	2.5mm	5.7mm	M3	DTRNMS 306 01
	7.9mm				DTRNMS 308 01
	9.9mm				DTRNMS 310 01
	12.2mm				DTRNMS 312 01
	7.9mm	2.7mm	7.4mm	M4	DTRNMS 408 01

www.element14.com
www.farnell.com
www.newark.com
www.cpc.co.uk
www.mcmelectronics.com

Important Notice : This data sheet and its contents (the "Information") belong to the members of the Premier Farnell group of companies (the "Group") or are licensed to it. No licence is granted for the use of it other than for information purposes in connection with the products to which it relates. No licence of any intellectual property rights is granted. The Information is subject to change without notice and replaces all data sheets previously supplied. The Information supplied is believed to be accurate but the Group assumes no responsibility for its accuracy or completeness, any error in or omission from it or for any use made of it. Users of this data sheet should check for themselves the Information and the suitability of the products for their purpose and not make any assumptions based on information included or omitted. Liability for loss or damage resulting from any reliance on the Information or use of it (including liability resulting from negligence or where the Group was aware of the possibility of such loss or damage arising) is excluded. This will not operate to limit or restrict the Group's liability for death or personal injury resulting from its negligence. DURATOOL is the registered trademark of the Group. © Premier Farnell plc 2012.

TOLERANCES:

UNLESS OTHERWISE SPECIFIED, DIMENSIONS ARE FOR REFERENCE PURPOSES ONLY.

DRAWN BY:	DATE:
SN	23/03/15
CHECKED BY:	DATE:
ER	23/03/15
APPROVED BY:	DATE:
ER	23/03/15

DRAWING TITLE:

Nylon Metric Screw Phillips Pan Head

SIZE	DWG NO.	ELECTRONIC FILE	REV
A4	DTRNMS 306 01-02	DTRNMS	1.0
SCALE: NTS		U.O.M.: mm	SHEET: 1 of 1