

DEBUR AND BREAK SHARP EDGES

DO NOT SCALE DRAWING

REVISION

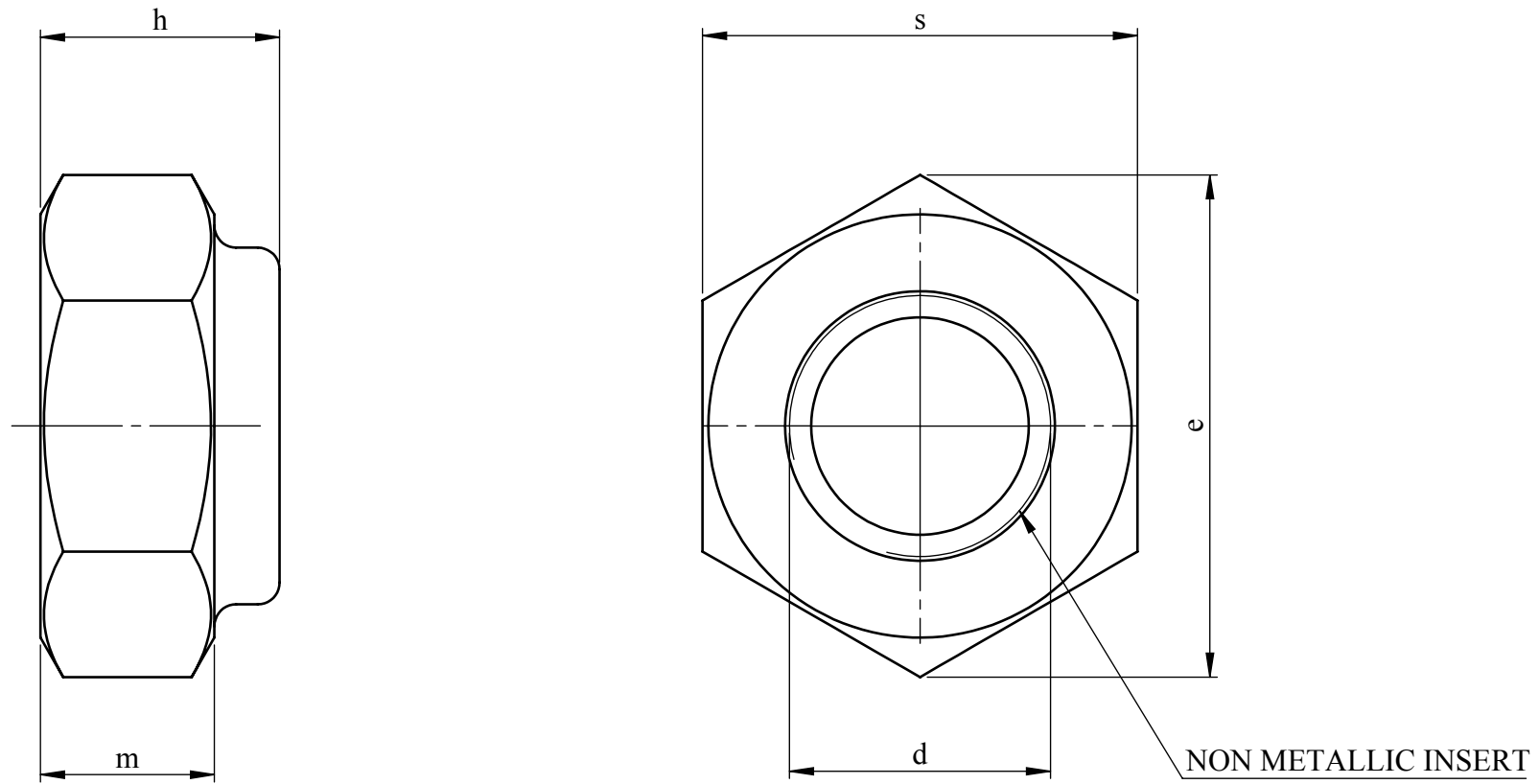

THREAD	KIT QTY	m	s	h	e
M3	160	2.4	5.5	4.0	6.1
M4	100	2.9	7.0	5.0	7.7
M5	50	3.2	8.0	5.0	8.8
M6	75	4.0	10.0	6.0	11.1
M8	40	5.5	13.0	8.0	14.4
M10	40	6.5	17.0	10.0	19.0
M12	30	8.0	19.0	12.0	21.1

A DRAWN 03/07/15

NOTES

DIN 985, TYPE T



DESIGN RIGHT. TR FASTENINGS LTD, 2003
 UNDER NO CIRCUMSTANCES MUST THIS
 DRAWING BE COPIED OR DISCLOSED,
 WITHOUT FIRST OBTAINING WRITTEN
 AUTHORITY.

UNLESS OTHERWISE SPECIFIED:
 DIMENSIONS ARE IN MILLIMETERS
 SURFACE FINISH:
 TOLERANCES:

ISO 2768 m	
NAME	DATE
DRAWN MARTIN ELLIOTT	03/07/15
CHK'D	
APPV'D	

CUSTOMER PART No

MATERIAL:

STEEL

HEAT TREATMENT

FINISH:

ZINC PLATED

TITLE:

HEXAGON LOCK NUT KIT

DWG NO.

TRFAKIT0010

A3

PROJECTION

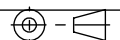

SHEET 1 OF 1