

DO NOT SCALE FROM THIS PRINT

QMS-XXX-XX.XX-XX-D-XX-XXX-XX

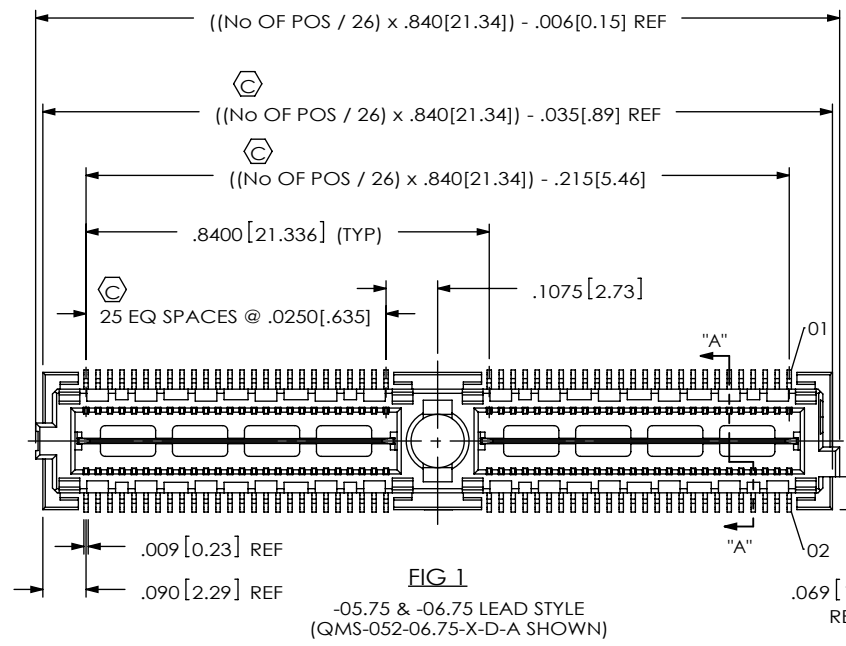

No OF POSITIONS (PER ROW)
-026, -052, -078, -104, * -130

LEAD STYLE (SEE NOTE 9)
-05.75 (SEE FIG 1)
-06.75 (SEE FIG 1)
**-09.75 (SEE FIG 4, SHEET 3)

PLATING SPECIFICATION

- H: 30μ" GOLD IN CONTACT AREA, 3μ" GOLD ON TAIL. (AVAILABLE ON -05.75 & -06.75 LEAD STYLE ONLY)
- L: 10μ" GOLD IN CONTACT AREA, MATTE TIN ON TAIL. (AVAILABLE ON -05.75 & -06.75 LEAD STYLE ONLY)
- S: 30μ" GOLD IN CONTACT AREA, MATTE TIN ON TAIL. (AVAILABLE ON -09.75 LEAD STYLE ONLY)
- SL: 10μ" GOLD IN CONTACT AREA, MATTE TIN ON TAIL. (AVAILABLE ON -09.75 LEAD STYLE ONLY)

ROW SPECIFICATION
-D: DOUBLE

OPTION

- A: ALIGNMENT PIN (AVAILABLE ON -05.75 & -06.75 LEAD STYLES ONLY)
- GP: GUIDE POSTS (SEE FIG 3, SHEET 2)
- K: KAPTON PAD (SEE FIG 2, SHEET 2)

PACKAGING OPTION
-TR: TAPE & REEL PACKAGING (-026 THRU -078 WITH NO OPTIONS) (-026 & -052 WITH -GP, -PXX, -RF1, -RT1) (-026 WITH RF2)

END OPTION

- PC4: POWER COMBO 4 (.062" THICK BOARD) (SEE FIG 5, SHEET 4)
- PC8: POWER COMBO 8 (.062" THICK BOARD) (SEE FIG 5, SHEET 4)
- PT4: POWER COMBO 4 (.093" THICK BOARD) (SEE FIG 5, SHEET 4)
- PT8: POWER COMBO 8 (.093" THICK BOARD) (SEE FIG 5, SHEET 4)
- RF1: 1 RF POS PER END (SEE FIG 6, SHEET 5)
- RF2: 2 RF POS PER END (SEE FIG 7, SHEET 5)
- RT1: 1 RT POS PER END (SEE FIG 8, SHEET 6)

(-PXX & -RFX NOT AVAILABLE IN COMBINATION WITH -A, -GP, OR -K) (END OPTION APPLIES TO BOTH ENDS, COMBINATIONS ARE NOT AVAILABLE) (-PXX & -RFX AVAILABLE IN POS -026, -052, & -078 ONLY) (-RFX & -RT1 AVAILABLE ON -05.75 LEAD STYLE ONLY) (-RT1 AVAILABLE IN -026, -052, -078, & -104 POS WITH -A OPTION ONLY) (-PXX AVAILABLE ON -05.75 & -06.75 LEAD STYLES ONLY)

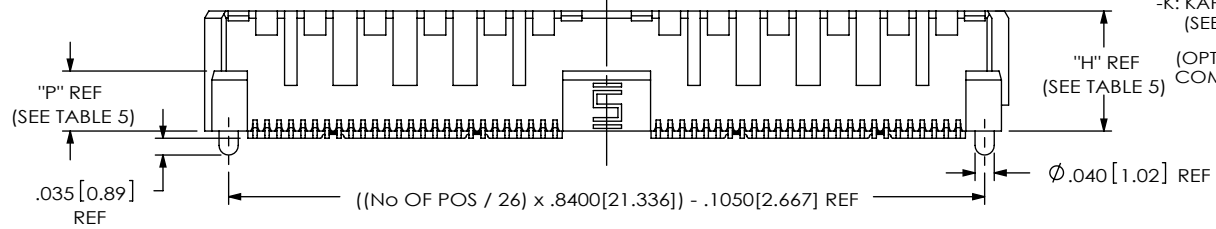

(OPTIONS NOT AVAILABLE IN COMBINATION WITH -PXX OR -RFX)

* = NOT TOOLED
** = SEE NOTE 10

TABLE 5

LEAD STYLE	"H"	"J"	"P"	QMS BODY	QMS STACKER BODY	TERMINAL	GROUND PLANE	MATED TO QFS-XX-XX
-05.75	.212 [5.38]	.2268 [5.761]	.085 [2.16]	QMSS-26-05.75-D-XX-A	N/A	T-1M19-05.75-XX	T-1G19-05.75-L	QFS-04.25 QFS-06.25
-06.75	.250 [6.35]	.2650 [6.731]	.125 [3.18]	QMSS-26-06.75-D-XX-A	N/A	T-1M19-06.75-XX	T-1G19-06.75-L	QFS-04.25 QFS-06.25
-09.75	.368 [9.35]	.3830 [9.728]	.085 [2.16]	QMSS-26-05.75-D-XX	QTSH-26-01-D-XX-A	T-1M19-09.75-XX	T-1G19-09.75-L	QFS-04.25 QFS-06.25

TABLE 1

No OF POSITIONS	No OF BANKS	COPLANARITY
-026 AND -052	1 AND 2	.004[.10]
-078 THRU *-130	3 THRU 5	.006[.15]

* = NOT TOOLED

SEE NOTE 4

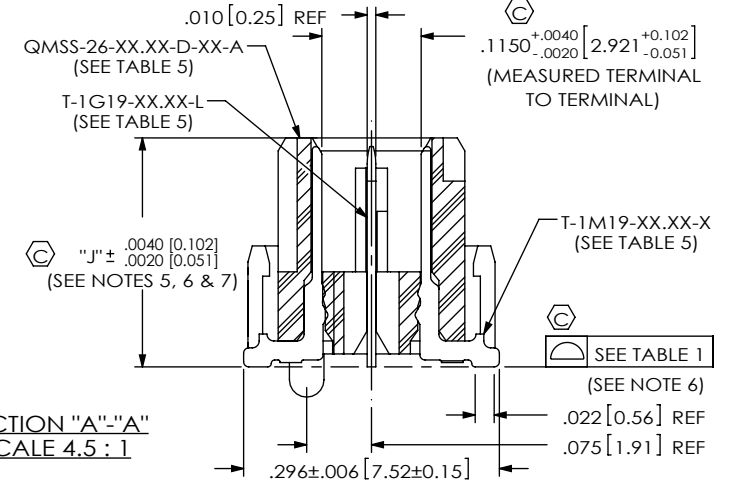
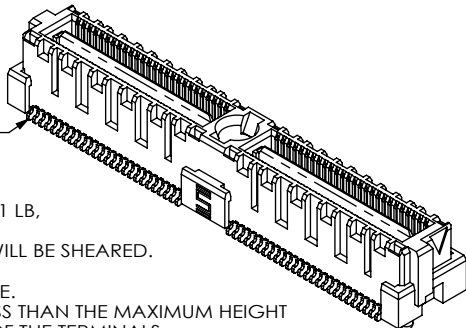

- NOTES:
- ⊕ REPRESENTS A CRITICAL DIMENSION.
 - MAXIMUM BURR ALLOWANCE: .0015
 - MINIMUM PUSHOUT FORCE: SIGNAL: .5 LB, GROUND: 1 LB, POWER: .5 LB, RF: .5 LB.
 - ALL TERMINALS ON THE -05.75 & -06.75 LEAD STYLES WILL BE SHEARED.
 - MAXIMUM VARIANCE: .002[0.05]
 - DIMENSION APPLIES TO CONTACTS & GROUND PLANE.
 - GROUND PLANE PRESS HEIGHT MUST BE .003[0.08] LESS THAN THE MAXIMUM HEIGHT OR .001[0.03] GREATER THAN THE MINIMUM HEIGHT OF THE TERMINALS.
 - PARTS TO BE PACKAGED IN TRAYS.
 - LEADSTYLES -10 AND -11 MAY BE SUBSTITUTED IN PART CALLOUT FOR -05.75 AND -06.75 ACCORDINGLY FOR EXISTING CUSTOMERS ONLY.
 - 09.75 LEAD STYLE -078 AND -104 POSITION AVAILABLE TO EXISTING CUSTOMERS ONLY.

UNLESS OTHERWISE SPECIFIED, DIMENSIONS ARE IN INCHES.

TOLERANCES ARE:

DECIMALS ANGLES

.XX: ±.01[0.3]
.XXX: ±.005[0.13]
.XXXX: ±.0020[0.051]

PROPRIETARY NOTE
THIS DOCUMENT CONTAINS CONFIDENTIAL AND PROPRIETARY INFORMATION AND ALL DESIGN, MANUFACTURING, REPRODUCTION USE, PATENT RIGHTS AND SALES RIGHTS ARE EXPRESSLY RESERVED BY SAMTEC, INC. THIS DOCUMENT SHALL NOT BE DISCLOSED, IN WHOLE OR PART, TO ANY UNAUTHORIZED PERSON OR ENTITY NOR REPRODUCED, TRANSFERRED OR INCORPORATED IN ANY OTHER PROJECT IN ANY MANNER WITHOUT THE EXPRESS WRITTEN CONSENT OF SAMTEC, INC.

520 PARK EAST BLVD, NEW ALBANY, IN 47150
PHONE: 812-944-6733 FAX: 812-948-5047
e-Mail: info@SAMTEC.com code: 55322

MATERIAL: DO NOT SCALE DRAWING SHEET SCALE: 1:0.4
INSULATOR: LCP, UL 94V-0; COLOR: BLACK
TERMINAL & GROUND PLANE: PHOS BRONZE

DESCRIPTION: .635mm DOUBLE ROW TERMINAL STRIP
DWG. NO. QMS-XXX-XX.XX-XX-D-XX-XXX-XX
BY: E.L.S. 10/12/2010 SHEET 1 OF 6

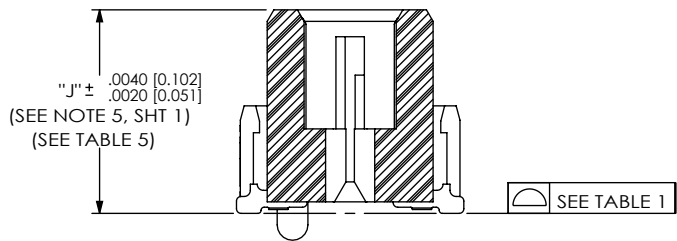

IN-PROCESS 1

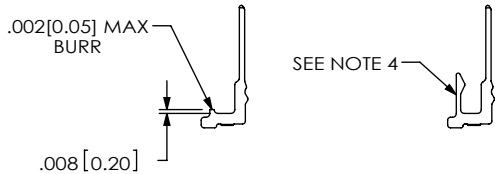

TERMINAL DETAILS

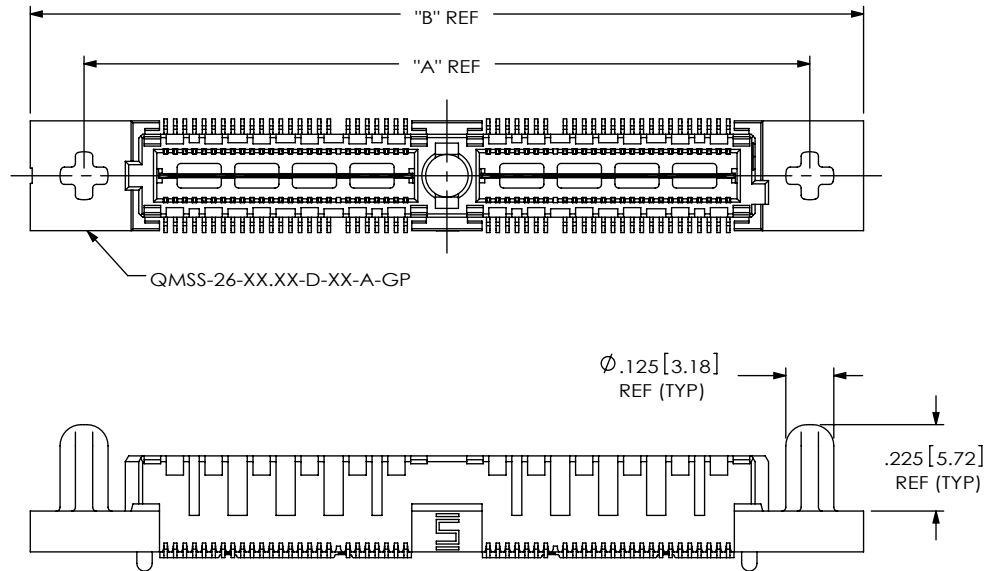

FIG 3

-GP: GUIDE POST OPTION
(QMS-052-06.75-X-D-A-GP SHOWN)
(AVAILABLE ON -.05.75 & -.06.75 LEAD STYLES ONLY)

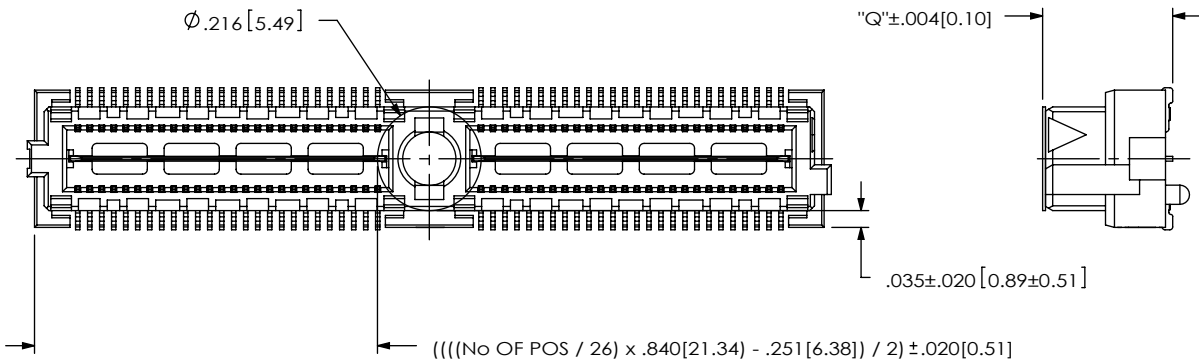

FIG 2

-K: POLYIMIDE PAD OPTION
(USE K-500-300)
(USE K-DOT-217-.313-.005 FOR -GP OPTION, NOT APPROVED
FOR VISION INTEGRATED PAD APPLICATION)
(QMS-052-06.75-X-D-A-K SHOWN)

LEAD STYLE	"Q"
-.05.75	.233 [5.91]
-.06.75	.271 [6.88]
-.09.75	.389 [9.88]

ASSEMBLY	"A"	"B"
QMS-026-XX-X-D-A-GP	1.050 [26.67]	1.330 [33.78]
QMS-052-XX-X-D-A-GP	1.890 [48.00]	2.170 [55.12]
QMS-078-XX-X-D-A-GP	2.730 [69.34]	3.010 [76.45]
QMS-104-XX-X-D-A-GP	3.570 [90.68]	3.850 [97.79]
* QMS-130-XX-X-D-A-GP	4.410 [112.01]	4.690 [119.13]

*** NOT TOOLED**

PROPRIETARY NOTE
THIS DOCUMENT CONTAINS CONFIDENTIAL AND PROPRIETARY INFORMATION AND ALL DESIGN, MANUFACTURING, REPRODUCTION, USE, PATENT RIGHTS AND SALES RIGHTS ARE EXPRESSLY RESERVED BY SAMTEC, INC. THIS DOCUMENT SHALL NOT BE DISCLOSED, IN WHOLE OR PART, TO ANY UNAUTHORIZED PERSON OR ENTITY NOR REPRODUCED, TRANSFERRED OR INCORPORATED IN ANY OTHER PROJECT IN ANY MANNER WITHOUT THE EXPRESS WRITTEN CONSENT OF SAMTEC, INC.

DO NOT SCALE DRAWING

SHEET SCALE: 1:0.4



520 PARK EAST BLVD, NEW ALBANY, IN 47150
PHONE: 812-944-6733 FAX: 812-948-5047
e-Mail: info@SAMTEC.com code: 55322

DESCRIPTION:
.635mm DOUBLE ROW TERMINAL STRIP

DWG. NO.
QMS-XXX-XX.XX-XX-D-XX-XXX-XX

BY: E.L.S. 10/12/2010 SHEET 2 OF 6

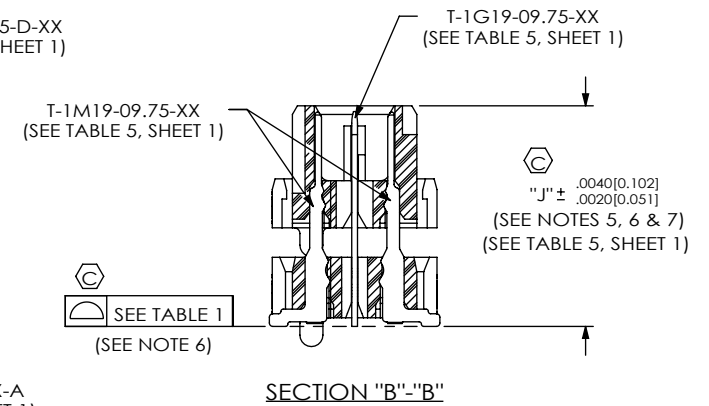
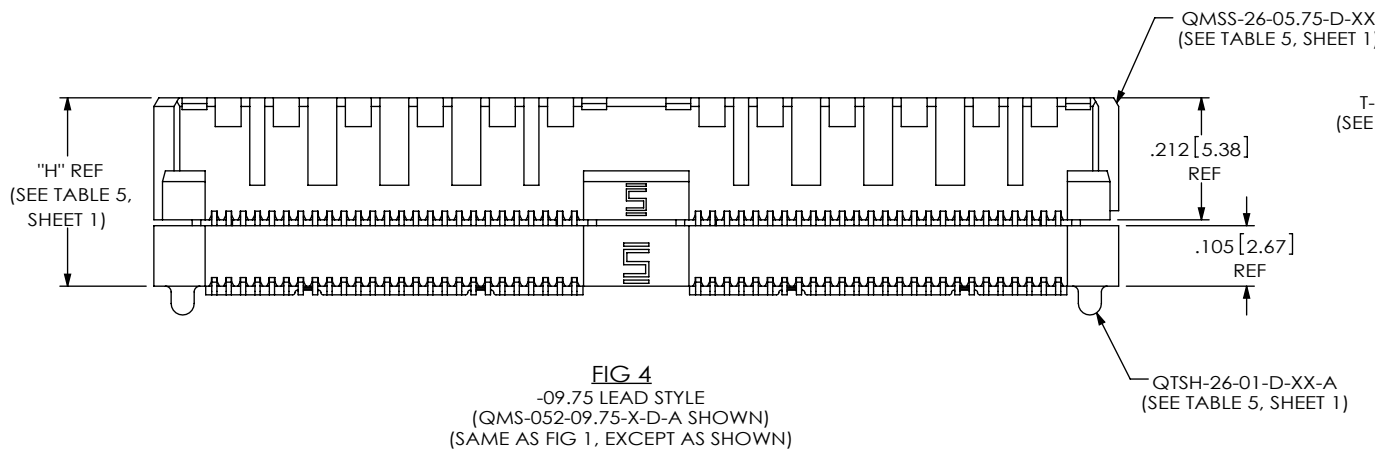
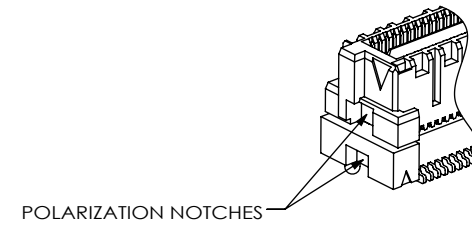
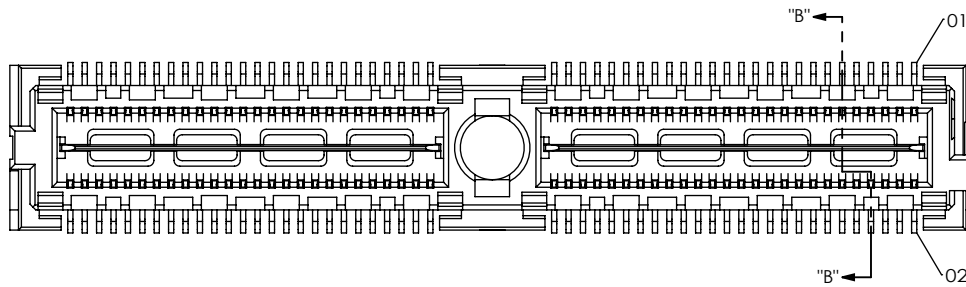

PROPRIETARY NOTE
THIS DOCUMENT CONTAINS CONFIDENTIAL AND PROPRIETARY INFORMATION AND ALL DESIGN, MANUFACTURING, REPRODUCTION, USE, PATENT RIGHTS AND SALES RIGHTS ARE EXPRESSLY RESERVED BY SAMTEC, INC. THIS DOCUMENT SHALL NOT BE DISCLOSED, IN WHOLE OR PART, TO ANY UNAUTHORIZED PERSON OR ENTITY NOR REPRODUCED, TRANSFERRED OR INCORPORATED IN ANY OTHER PROJECT IN ANY MANNER WITHOUT THE EXPRESS WRITTEN CONSENT OF SAMTEC, INC.

DO NOT SCALE DRAWING

SHEET SCALE: 3:1

samtec

520 PARK EAST BLVD, NEW ALBANY, IN 47150
PHONE: 812-944-6733 FAX: 812-948-5047
e-Mail: info@SAMTEC.com code: 55322

DESCRIPTION:
.635mm DOUBLE ROW TERMINAL STRIP

DWG. NO.
QMS-XXX-XX.XX-XX-D-XX-XXX-XX

BY: E.L.S. 10/12/2010 SHEET 3 OF 6

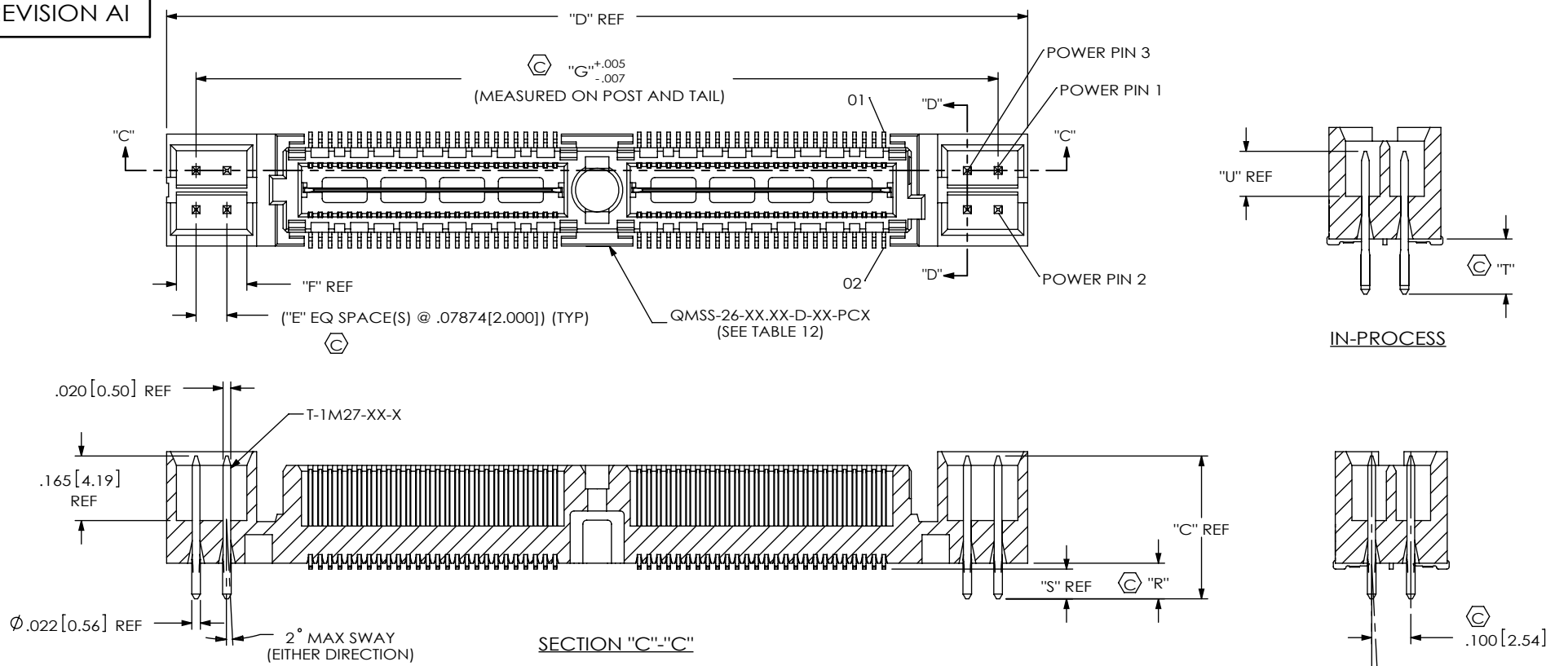

FIG 5
 -PXX OPTION
 POWER COMBO OPTIONS
 QMS-052-06.75-X-D-PC4 SHOWN
 (SAME AS FIG 1, UNLESS OTHERWISE STATED)
 [NOT AVAILABLE WITH -A, -GP OR -K OPTION, AVAILABLE ON LEAD STYLES -05.75 & -06.75 ONLY]
 (AVAILABLE ON -026, -052 & -078 POSITIONS ONLY)

ASSEMBLY	"D"	"E"	"F"	"G"
QMS-026-XX.XX-X-D-X-PX4	1.360[34.54]	1	.180[4.57]	1.209[30.71]
QMS-026-XX.XX-X-D-X-PX8	1.675[42.55]	3	.337[8.56]	1.524[38.71]
QMS-052-XX.XX-X-D-X-PX4	2.200[55.88]	1	.180[4.57]	2.049[52.04]
QMS-052-XX.XX-X-D-X-PX8	2.515[63.88]	3	.337[8.56]	2.364[60.05]
QMS-078-XX.XX-X-D-X-PX4	3.040[77.22]	1	.180[4.57]	2.889[73.38]
QMS-078-XX.XX-X-D-X-PX8	3.355[85.22]	3	.337[8.56]	3.204[81.38]

LEAD STYLE	POWER OPTION	BODY
-06.75	PX4	QMSS-26-06.75-D-XX-PC4
-06.75	PX8	QMSS-26-06.75-D-XX-PC8
-05.75	PX4	QMSS-26-05.75-D-XX-PC4
-05.75	PX8	QMSS-26-05.75-D-XX-PC8

LEAD STYLE	POWER OPTION	TERMINAL	"C"	"R"	"S"	"T"	"U"
-06.75	PCX	T-1M27-01-S	.365[9.27]	.091[2.31]	.076[1.93]	.132[3.35]	.124[3.15]
-06.75	PTX	T-1M27-03-S	.400[10.16]	.126[3.20]	.111[2.82]	.132[3.35]	.159[4.04]
-05.75	PCX	T-1M27-02-S	.326[8.28]	.086[2.18]	.071[1.80]	.172[4.37]	.079[2.01]
-05.75	PTX	T-1M27-01-S	.365[9.27]	.125[3.18]	.110[2.79]	.172[4.37]	.118[3.00]

PROPRIETARY NOTE
 THIS DOCUMENT CONTAINS CONFIDENTIAL AND PROPRIETARY INFORMATION AND ALL DESIGN, MANUFACTURING, REPRODUCTION, USE, PATENT RIGHTS AND SALES RIGHTS ARE EXPRESSLY RESERVED BY SAMTEC, INC. THIS DOCUMENT SHALL NOT BE DISCLOSED, IN WHOLE OR PART, TO ANY UNAUTHORIZED PERSON OR ENTITY NOR REPRODUCED, TRANSFERRED OR INCORPORATED IN ANY OTHER PROJECT IN ANY MANNER WITHOUT THE EXPRESS WRITTEN CONSENT OF SAMTEC, INC.
 DO NOT SCALE DRAWING
 SHEET SCALE: 1:0.4

samtec
 520 PARK EAST BLVD, NEW ALBANY, IN 47150
 PHONE: 812-944-6733 FAX: 812-948-5047
 e-Mail: info@SAMTEC.com code: 55322

DESCRIPTION:
 .635mm DOUBLE ROW TERMINAL STRIP
 DWG. NO.
QMS-XXX-XX.XX-XX-D-XX-XXX-XX
 BY: E.L.S. 10/12/2010 SHEET 4 OF 6

TABLE 7			
ASSEMBLY	QMSS-26-05.75-D-XX-RFX	"K"	"L"
QMS-026-05.75-X-D-RF1	QMSS-26-05.75-D-01-RF1	1.425[36.20]	1.153[29.29]
QMS-026-05.75-X-D-RF2	QMSS-26-05.75-D-01-RF2	1.925[48.90]	1.653[41.99]
QMS-052-05.75-X-D-RF1	QMSS-26-05.75-D-02-RF1	2.265[57.53]	1.993[50.62]
QMS-052-05.75-X-D-RF2	QMSS-26-05.75-D-02-RF2	2.765[70.23]	2.493[63.32]
QMS-078-05.75-X-D-RF1	QMSS-26-05.75-D-03-RF1	3.105[78.87]	2.833[71.96]
QMS-078-05.75-X-D-RF2	QMSS-26-05.75-D-03-RF2	3.605[91.57]	3.333[84.66]

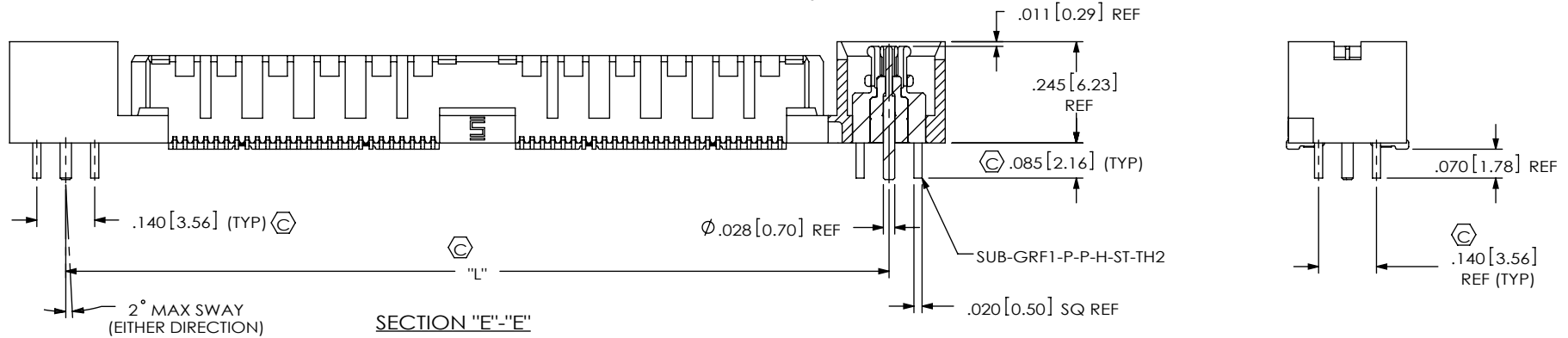
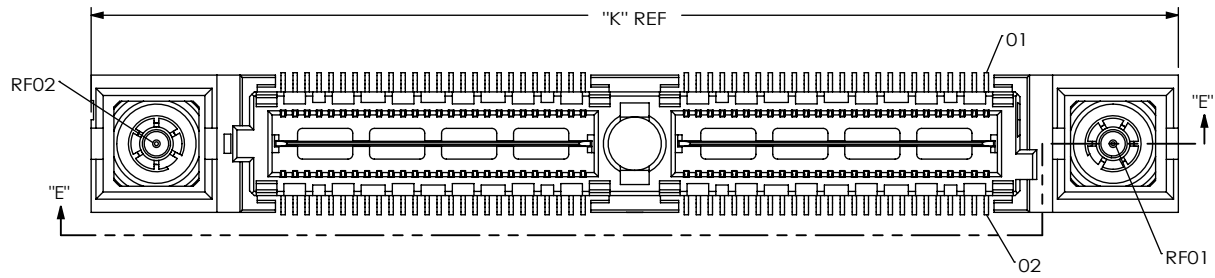

FIG 6
 -RF1 OPTION
 QMS-052-05.75-X-D-RF1 SHOWN
 (SAME AS FIG 1, UNLESS OTHERWISE STATED)
 [NOT AVAILABLE WITH -A OR -GP OPTION, AVAILABLE ON LEAD STYLE -05.75 ONLY]
 (AVAILABLE ON -026, -052 & -078 POSITIONS ONLY)

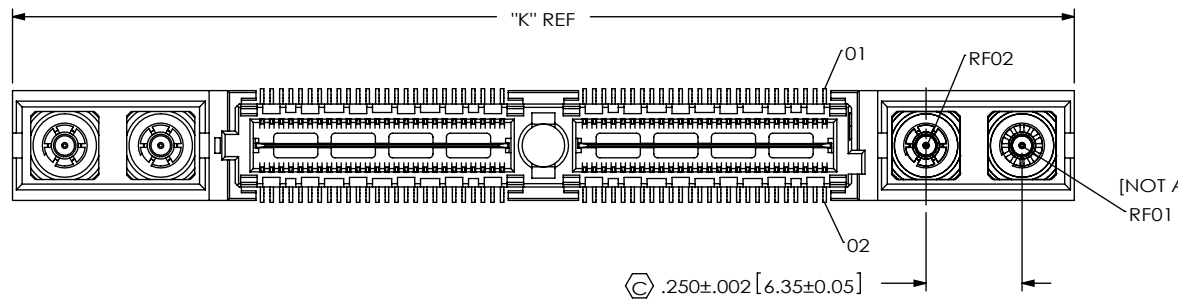
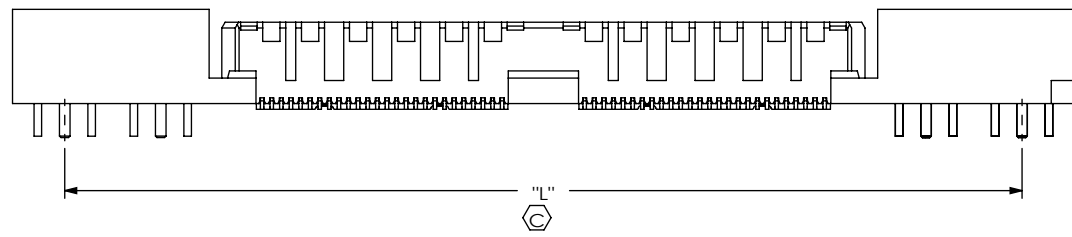

FIG 7
 -RF2 OPTION
 QMS-052-05.75-X-D-RF2 SHOWN
 (SAME AS FIG 6, UNLESS OTHERWISE STATED)
 [NOT AVAILABLE WITH -A OR -GP OPTION, AVAILABLE ON LEAD STYLE -05.75 ONLY]
 (AVAILABLE ON -026, -052 & -078 POSITIONS ONLY)



PROPRIETARY NOTE
 THIS DOCUMENT CONTAINS CONFIDENTIAL AND PROPRIETARY INFORMATION AND ALL DESIGN, MANUFACTURING, REPRODUCTION, USE, PATENT RIGHTS AND SALES RIGHTS ARE EXPRESSLY RESERVED BY SAMTEC, INC. THIS DOCUMENT SHALL NOT BE DISCLOSED, IN WHOLE OR PART, TO ANY UNAUTHORIZED PERSON OR ENTITY NOR REPRODUCED, TRANSFERRED OR INCORPORATED IN ANY OTHER PROJECT IN ANY MANNER WITHOUT THE EXPRESS WRITTEN CONSENT OF SAMTEC, INC.

DO NOT SCALE DRAWING
 SHEET SCALE: 1:0.4

samtec
 520 PARK EAST BLVD, NEW ALBANY, IN 47150
 PHONE: 812-944-6733 FAX: 812-948-5047
 e-Mail: info@SAMTEC.com code: 55322

DESCRIPTION:
 .635mm DOUBLE ROW TERMINAL STRIP

DWG. NO.
QMS-XXX-XX.XX-XX-D-XX-XXX-XX

BY: E.L.S. 10/12/2010 SHEET 5 OF 6

TABLE 8			
ASSEMBLY	QMS-26-05.75-D-XX-A-RTX	"M"	"N"
QMS-026-05.75-X-D-A-RT1	QMS-26-05.75-D-01-A-RT1	1.425[36.20]	1.153[29.29]
QMS-052-05.75-X-D-A-RT1	QMS-26-05.75-D-02-A-RT1	2.265[57.53]	1.993[50.62]
QMS-078-05.75-X-D-A-RT1	QMS-26-05.75-D-03-A-RT1	3.105[78.87]	2.833[71.96]
QMS-104-05.75-X-D-A-RT1	QMS-26-05.75-D-04-A-RT1	3.945[100.20]	3.673[93.29]

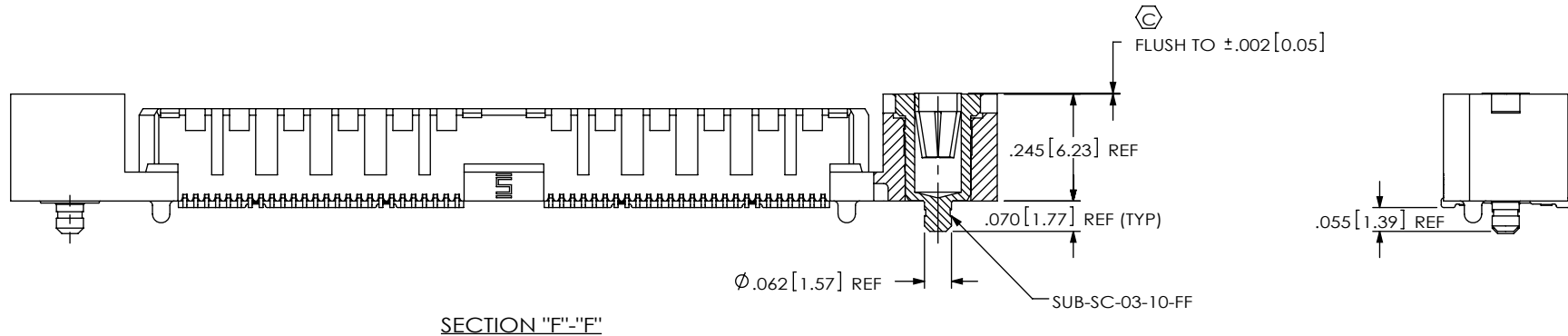
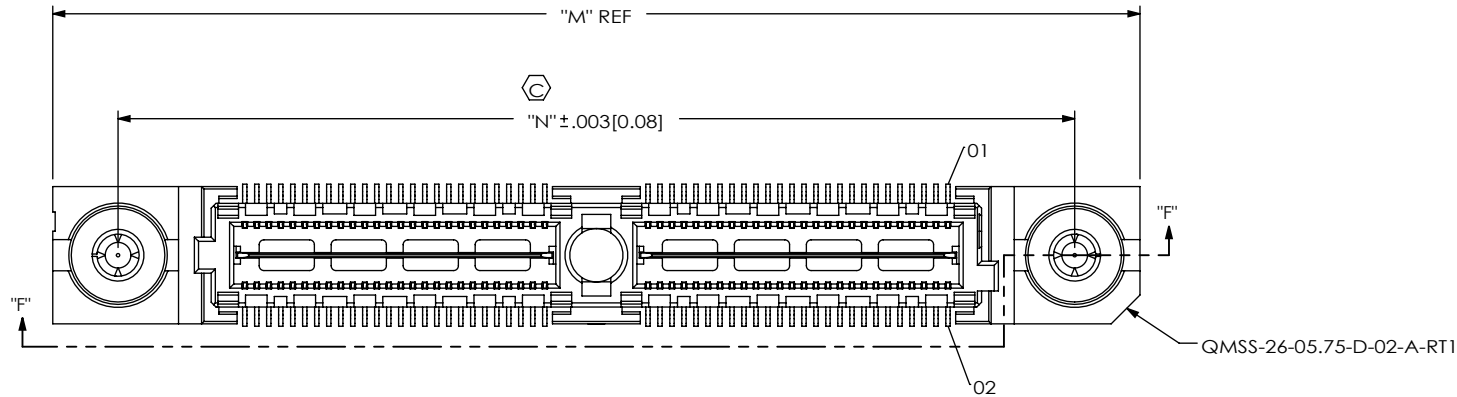

FIG 8

-RT1 OPTION
 QMS-052-05.75-X-D-A-RT1 SHOWN
 (SAME AS FIG 1, UNLESS OTHERWISE STATED)
 [NOT AVAILABLE WITH -GP, -PCX OR -RFX OPTION, AVAILABLE ON LEAD STYLE -05.75 ONLY]
 (AVAILABLE ON -026, -052, -078, & -104 POSITIONS WITH -A OPTION ONLY)

<p>PROPRIETARY NOTE</p> <p>THIS DOCUMENT CONTAINS CONFIDENTIAL AND PROPRIETARY INFORMATION AND ALL DESIGN, MANUFACTURING, REPRODUCTION, USE, PATENT RIGHTS AND SALES RIGHTS ARE EXPRESSLY RESERVED BY SAMTEC, INC. THIS DOCUMENT SHALL NOT BE DISCLOSED, IN WHOLE OR PART, TO ANY UNAUTHORIZED PERSON OR ENTITY NOR REPRODUCED, TRANSFERRED OR INCORPORATED IN ANY OTHER PROJECT IN ANY MANNER WITHOUT THE EXPRESS WRITTEN CONSENT OF SAMTEC, INC.</p> <p>DO NOT SCALE DRAWING</p> <p>SHEET SCALE: 1:0.4</p>	
	<p>520 PARK EAST BLVD, NEW ALBANY, IN 47150 PHONE: 812-944-6733 FAX: 812-948-5047 e-Mail: info@SAMTEC.com code: 55322</p>
	<p>DESCRIPTION: .635mm DOUBLE ROW TERMINAL STRIP</p>
	<p>DWG. NO. QMS-XXX-XX.XX-XX-D-XX-XXX-XX</p>
<p>BY: E.L.S. 10/12/2010 SHEET 6 OF 6</p>	