

LOC	DIST	REVISIONS					
GP	00	P	LTN	DESCRIPTION	DATE	DWN	APVD
		A		INITIAL RELEASE	20MAY2015	JW	SH

CAGE ASSEMBLY

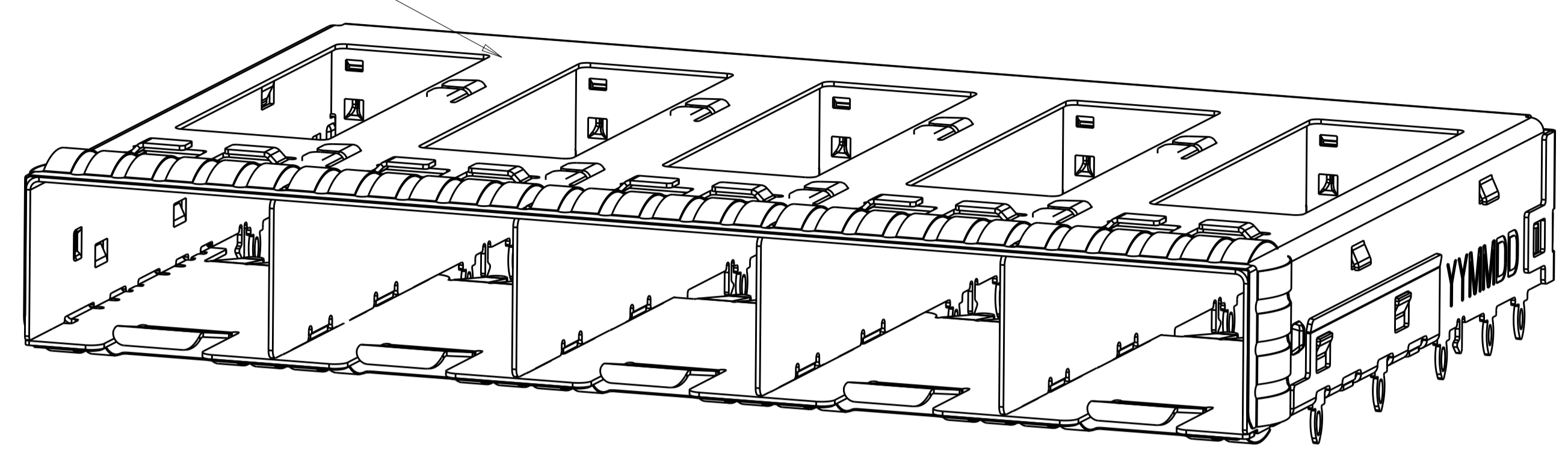

2284170-1
FINISHED ASSEMBLY

- 1. MATERIAL: 0.25mm THICK NICKEL SILVER ALLOY.
EMI SPRINGS: COPPER ALLOY.
- 2. FINISH:
SPRINGS: MINIMUM OF 0.8um TIN PLATE OVER A MINIMUM OF 0.8um NICKEL UNDERPLATE. NON-PLATED EDGES PERMISSIBLE.
- 3. MATES WITH SFP MSA COMPLIANT TRANSCEIVERS.
- 4. PADS AND VIAS CHASSIS GROUND.
- 5. INTERPRETATION OF DATUM REFERENCE FRAME IN ACCORDANCE WITH SECT 4.4.1.1 OF ASME Y14.5M-1994.
- 6. MINIMUM PCB BOARD THICKNESS:
SINGLE SIDED = 1.45mm
DOUBLE SIDED = 2.25mm
- 7. HOLE PATTERN REPEATS FOR EACH PORT. SPACING BETWEEN PORTS IS 14.25mm.
- 8. DATUM AND BASIC DIMENSION ESTABLISHED BY CUSTOMER.
- 9. REFERENCE APPLICATION SPEC. 114-13120, HOLE A, FOR RECOMMENDED DRILL HOLE DIAMETER AND PLATING THICKNESS.
- 10. REFERENCE APPLICATION SPEC. 114-13120, HOLE B, FOR RECOMMENDED DRILL HOLE DIAMETER AND PLATING THICKNESS.
- 11. CERTAIN MATING TRANSCEIVERS MAY REQUIRE ADDITIONAL PCB THICKNESS THAT WOULD BE DETERMINED BY THE CUSTOMER.
- 12. PRODUCT COMPLIES WITH SPECIFICATION SFF-8433 IMPROVED PLUGGABLE FORM FACTOR FOR SFP+ GANGED CAGES.

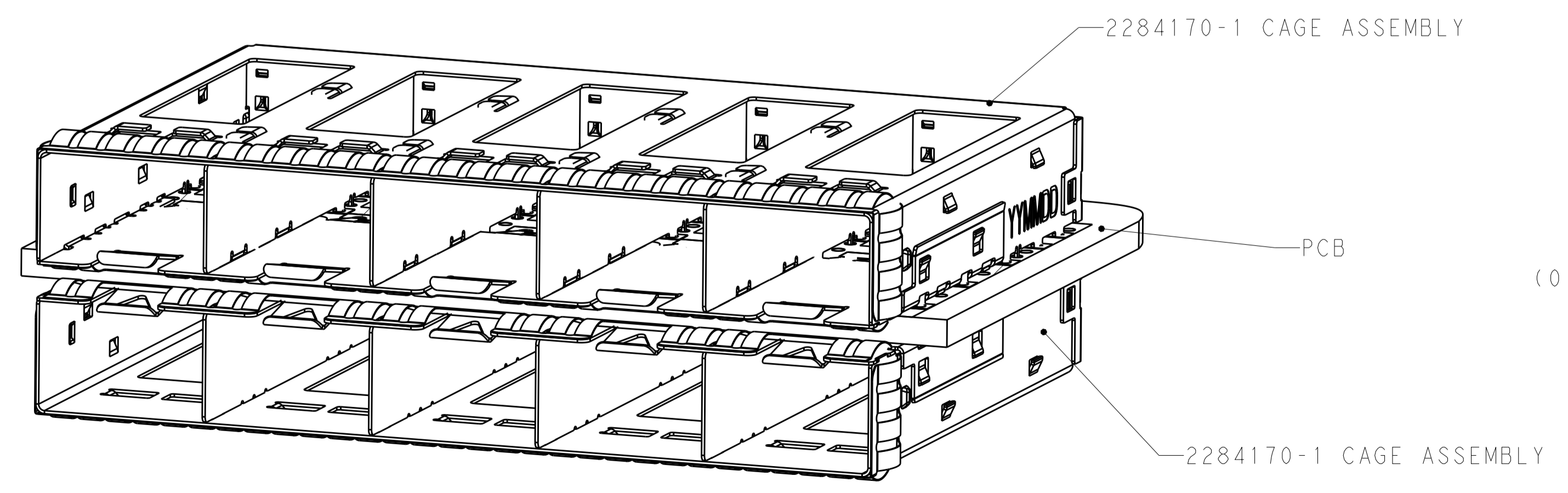
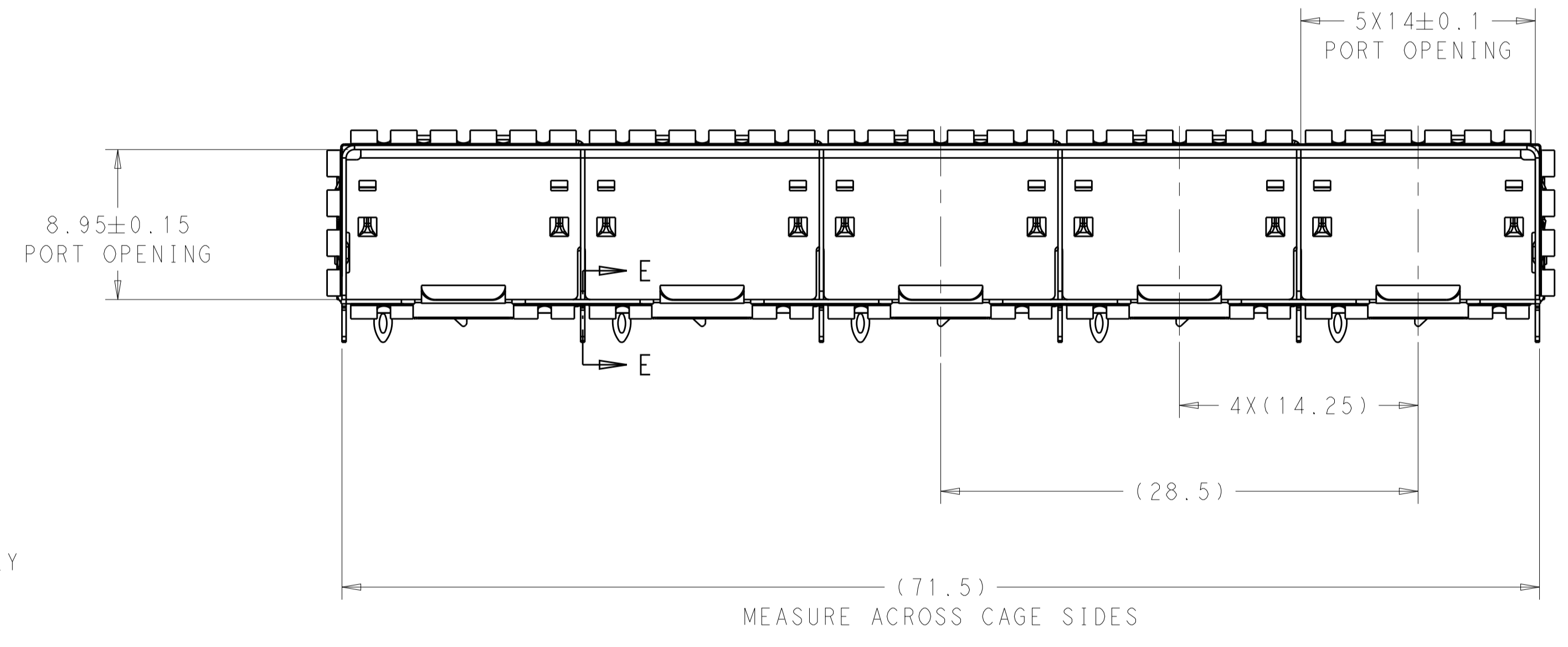
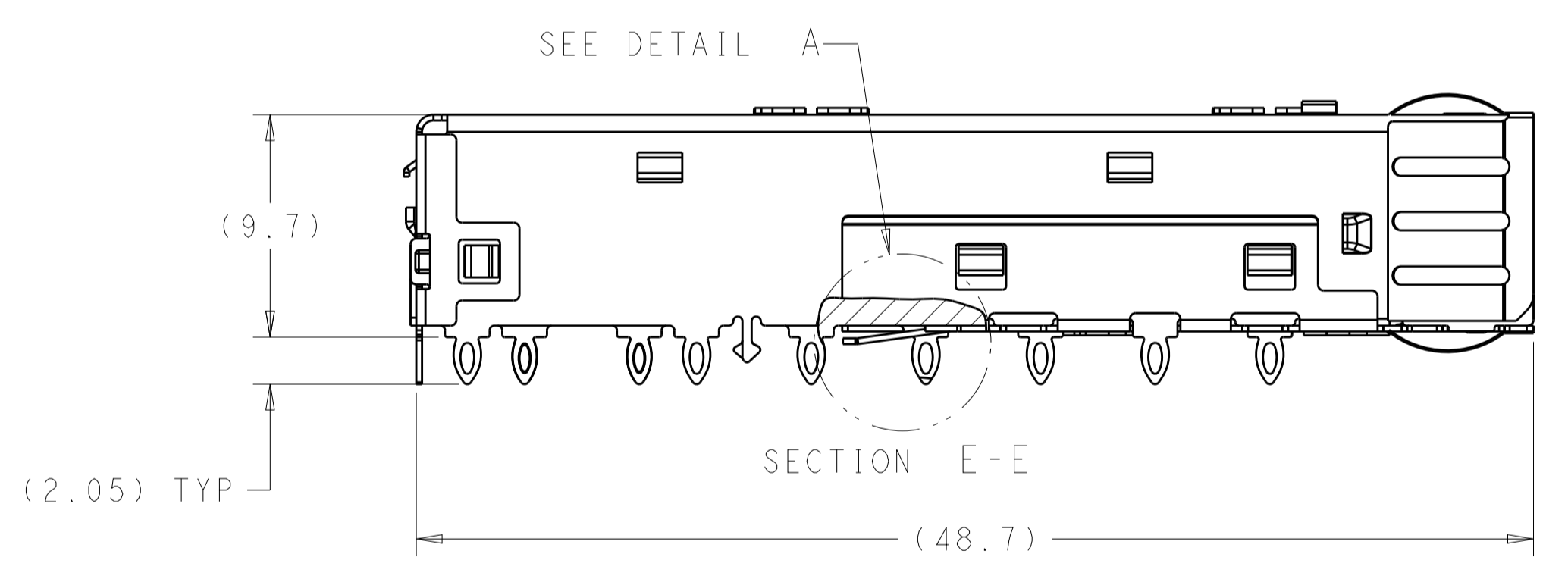

SCALE 3:1

2284170-1
MOUNTED BELLY TO BELLY ON PCB

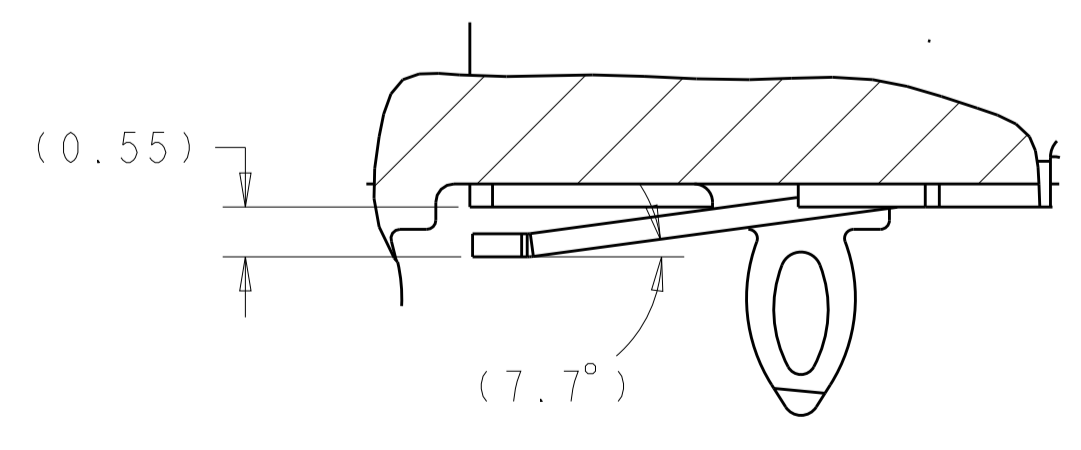

DETAIL A
25X INDIVIDUALLY
SCALE 12:1

2284170-1
PART NUMBER

THIS DRAWING IS A CONTROLLED DOCUMENT.		DWN: J. WANG 08AUG2014	TE Connectivity
DIMENSIONS: mm		CHK: S. HAN 08AUG2014	
TOLERANCES UNLESS OTHERWISE SPECIFIED:		APVD: S. HAN 08AUG2014	
0 PLC ±0.25 1 PLC ±0.25 2 PLC ±0.25 3 PLC ±0.25 4 PLC ±0.25 ANGLES ±		NAME: SFP+ ENHANCED 1X5 CAGE ASSEMBLY PRESS FIT, EXTERNAL EMI SPRINGS PRODUCT SPEC: 108-2364 APPLICATION SPEC: 114-13120 WEIGHT: - Customer Drawing	
MATERIAL:		FINISH: -	SIZE: A1 CAGE CODE: 00779 DRAWING NO: C=2284170 RESTRICTED TO: - SCALE: 4:1 SHEET 1 OF 4 REV A

LOC	DIST	REVISIONS			
GP	00	REV	DATE	BY	APPV
-	-	SEE SHEET 1	-	-	-

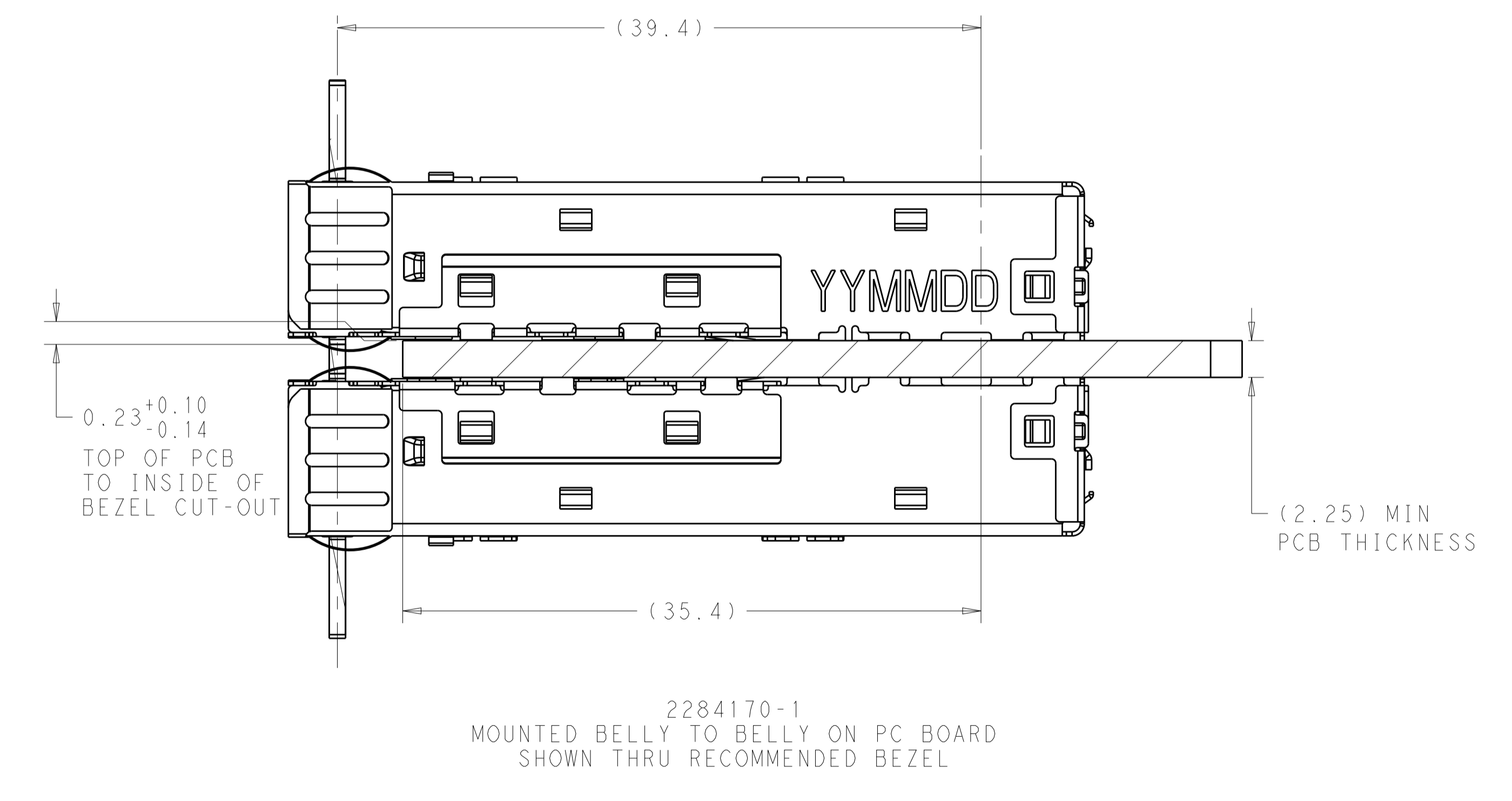
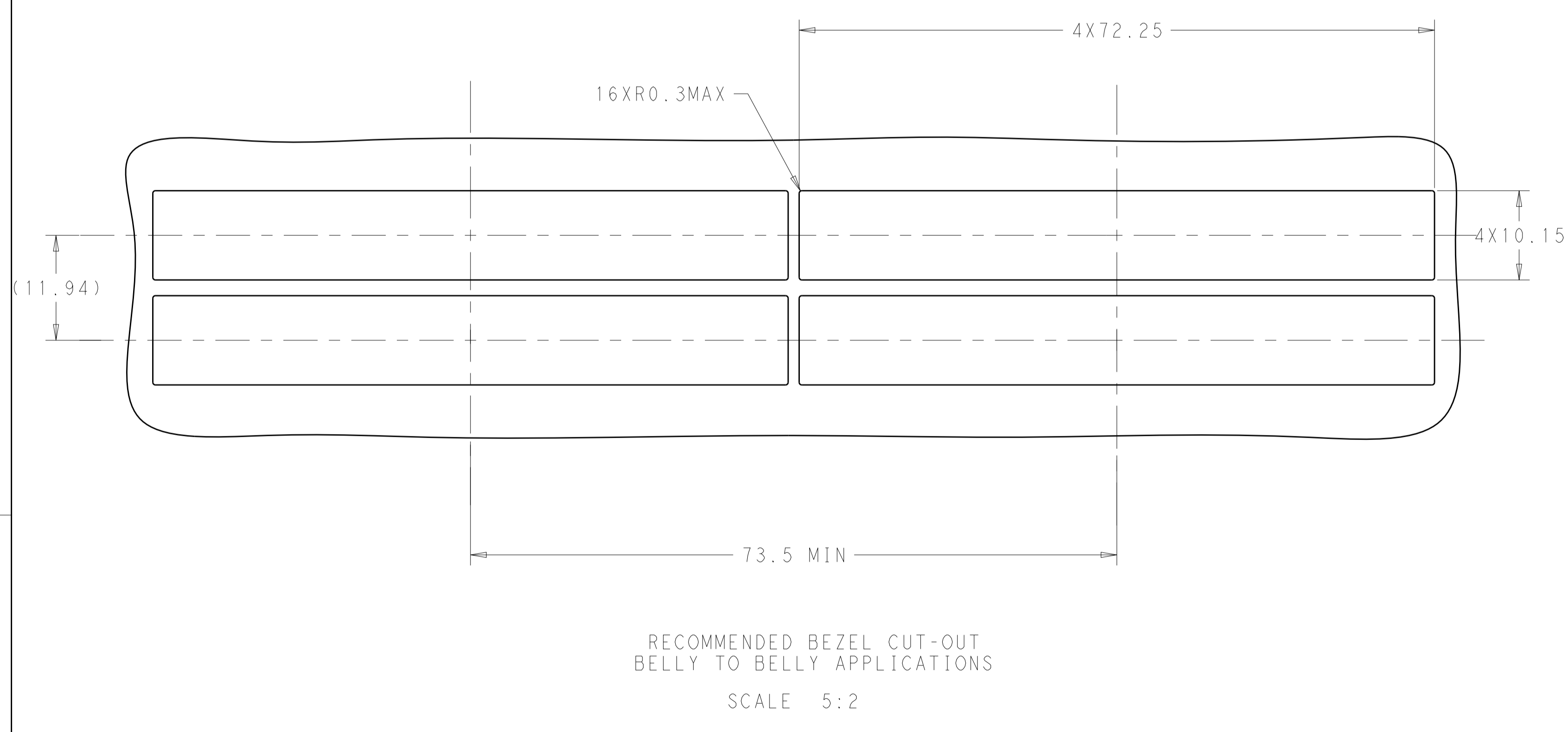
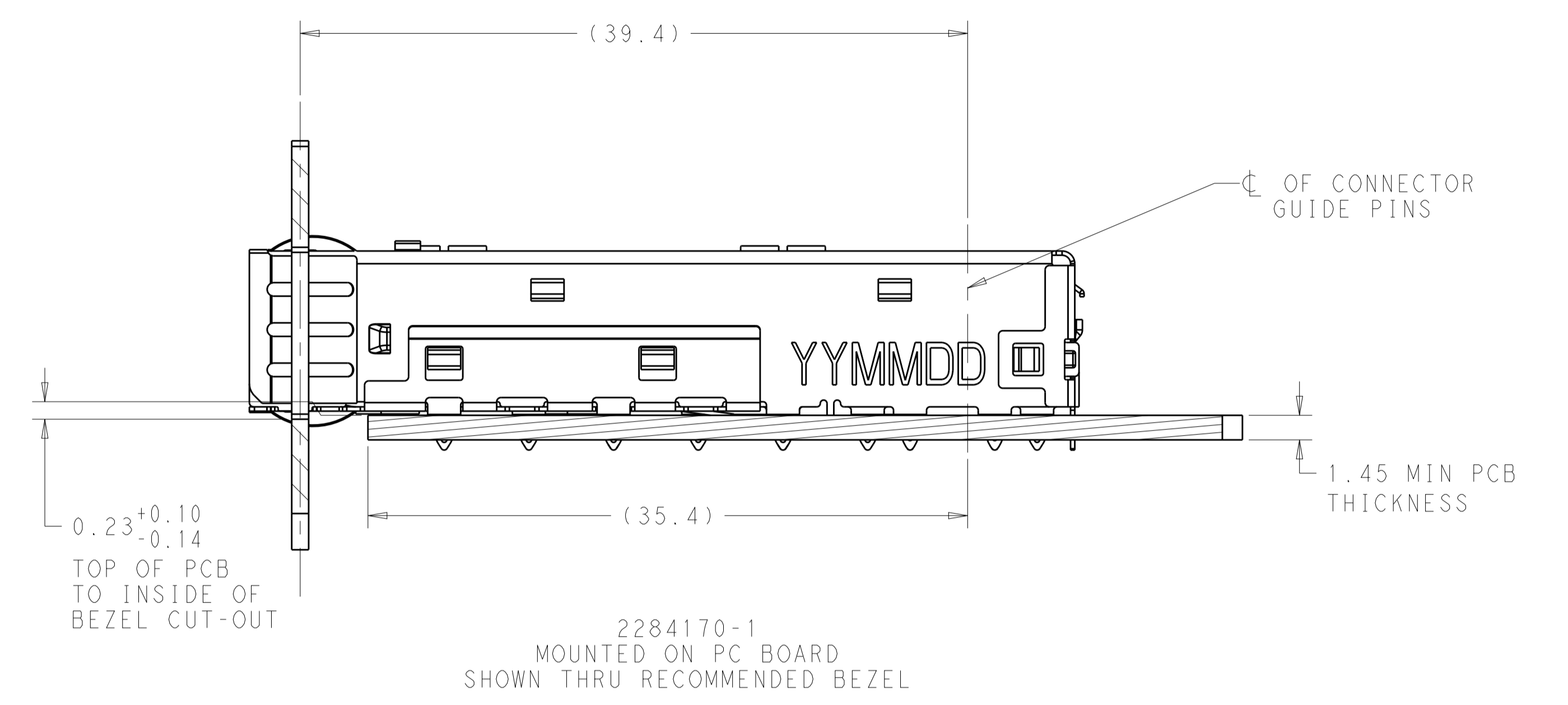
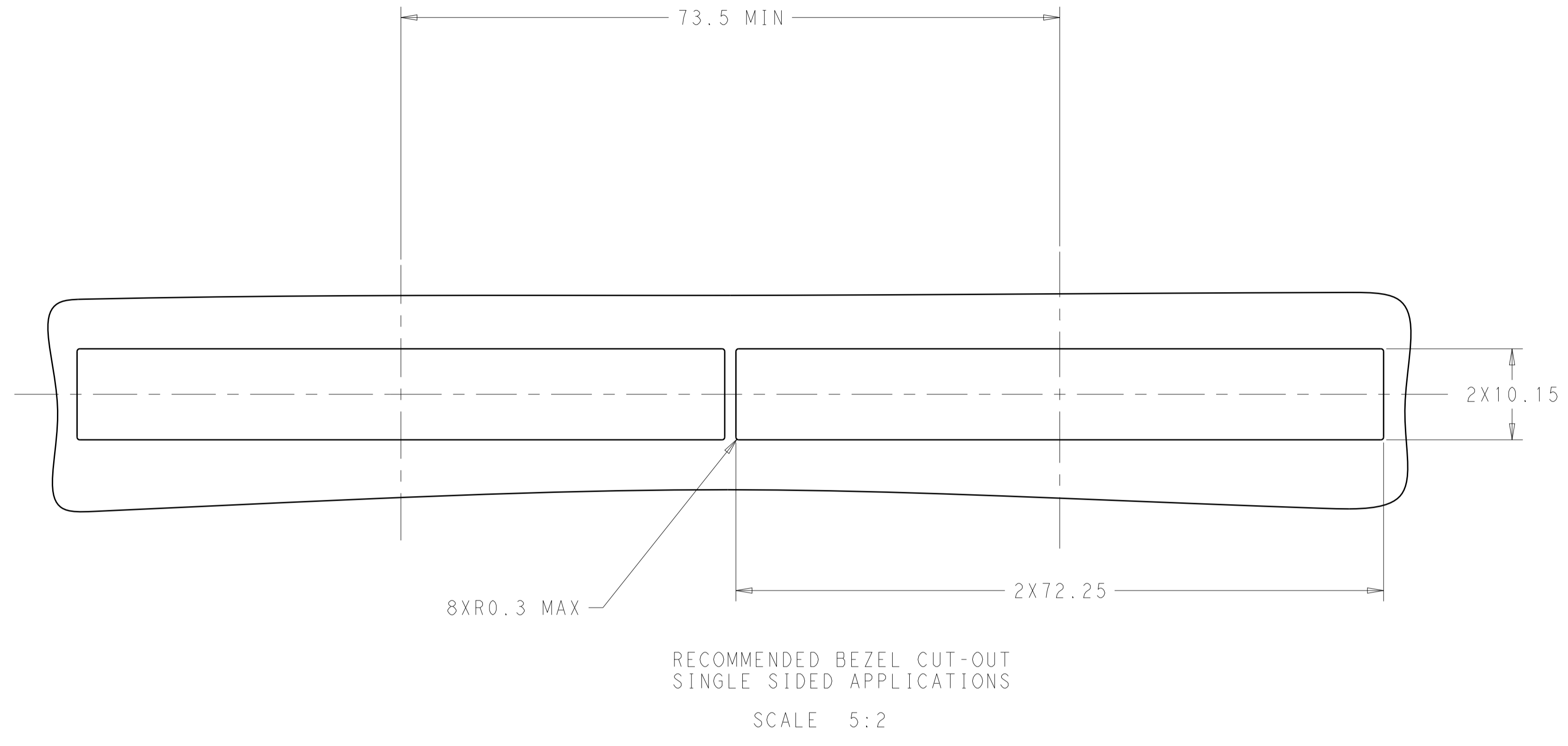

THIS DRAWING IS A CONTROLLED DOCUMENT.		DWN: J. WANG 08AUG2014	STE TE Connectivity
DIMENSIONS: mm		CHK: S. HAN 08AUG2014	
TOLERANCES UNLESS OTHERWISE SPECIFIED:		APPV: S. HAN 08AUG2014	NAME: SFP+ ENHANCED 1X5 CAGE ASSEMBLY PRESS FIT, EXTERNAL EMI SPRINGS
0 PLC ±0.1		PRODUCT SPEC	
1 PLC ±0.1		108-2364	SIZE: CAGE CODE DRAWING NO RESTRICTED TO
2 PLC ±0.1		APPLICATION SPEC	
3 PLC ±0.1		114-13120	A100779C=2284170
4 PLC ±		WEIGHT	
ANGLES ±		Customer Drawing	SCALE 4:1 SHEET 2 OF 4 REV A
FINISH			

