

CODE NO.	CONTACT	A	B	C	D	E	F	G	H	J
CL683-0002-2-57	20	10	6.8	5.5	4.5	9.8	8.2	7	10.4	7.6
CL683-0241-3-57	26	11.5	8.3	7	6	11.3	9.7	8.5	11.9	9.1
CL683-0003-5-57	30	12.5	9.3	8	7	12.3	10.7	9.5	12.9	10.1
CL683-0004-8-57	40	15	11.8	10.5	9.5	14.8	13.2	12	15.4	12.6
CL683-0005-0-57	50	17.5	14.3	13	12	17.3	15.7	14.5	17.9	15.1
CL683-0006-3-57	60	20	16.8	15.5	14.5	19.8	18.2	17	20.4	17.6
CL683-0007-6-57	70	22.5	19.3	18	17	22.3	20.7	19.5	22.9	20.1
CL683-0008-9-57	80	25	21.8	20.5	19.5	24.8	23.2	22	25.4	22.6

NOTES 1 : LEAD CO-PLANARITY INCLUDE REINFORCED METAL FITTINGS SHALL BE 0.1mm MAX.
 2 WATCH NOT LET THE CONTACTS TOUCH THE SECTION ESPECIALLY WHEN THE PADS OF AREA NOT RESIST FINISHED.

MATED HIGHT (h)		(mm)
HEADER NO.	RECEPTACLE NO.	
DF17#(2.0)-*DP-0.5V(57)	DF17#(3.0)-*DS-0.5V(57)	5
DF17#(4.0)-*DP-0.5V(57)		7

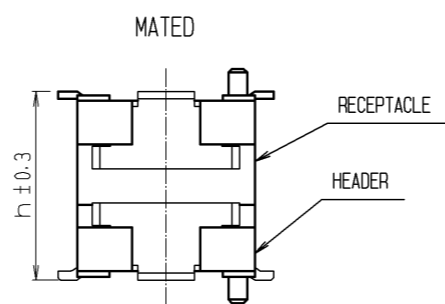

NO.	MATERIAL	FINISH . REMARKS	NO.	MATERIAL	FINISH . REMARKS
2	POLYAMIDE (PA6T)	WHITE BEIGE , UL94V-0	7	PS	CLEAR (REINFORCEMENT COLLAR)
1	PHOSPHER BRONZE	CONTACT AREA : GOLD PLATED 0.1µm min LEAD AREA : GOLD PLATED 0.02µm min UNDER PLATING : NICKEL 1µm min	6	PS	BLACK (PLASTIC REEL)
			5	POLYESTER	CLEAR (COVER TAPE)
			4	PS	CLEAR (EMBOSSED CARRIER TAPE)
			3	PHOSPHER BRONZE	TIN PLATED 1µm min UNDER PLATING : NICKEL 1µm min

UNITS	SCALE	COUNT	DESCRIPTION OF REVISIONS	DESIGNED	CHECKED	DATE
mm	5 : 1	3	DIS-H-008322	KR. AJITO	YH. MICHIDA	13. 11. 20

APPROVED	CHECKED	DESIGNED	DRAWN	DATE
KH. IKEDA	TS. MIYAZAKI	YH. MICHIDA	MS. SATO	11. 12. 12

DRAWING NO.	PART NO.	CODE NO.
EDC3-162127-77	DF17(3.0)-*DS-0.5V(57)	CL683

Aug.1.2016 Copyright 2016 HIROSE ELECTRIC CO., LTD. All Rights Reserved.

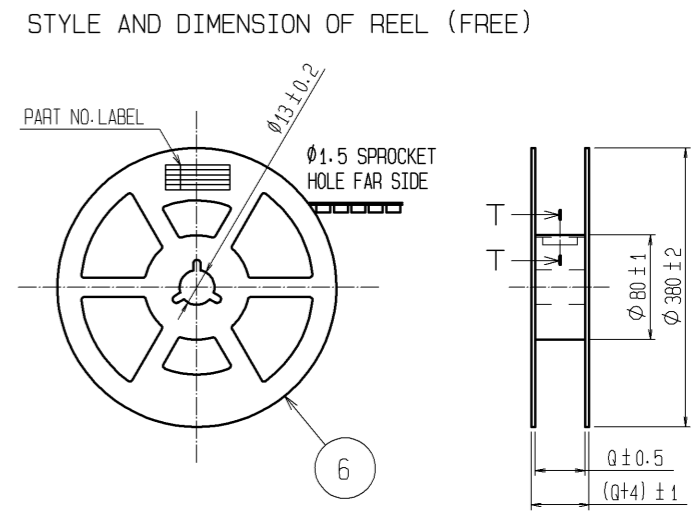
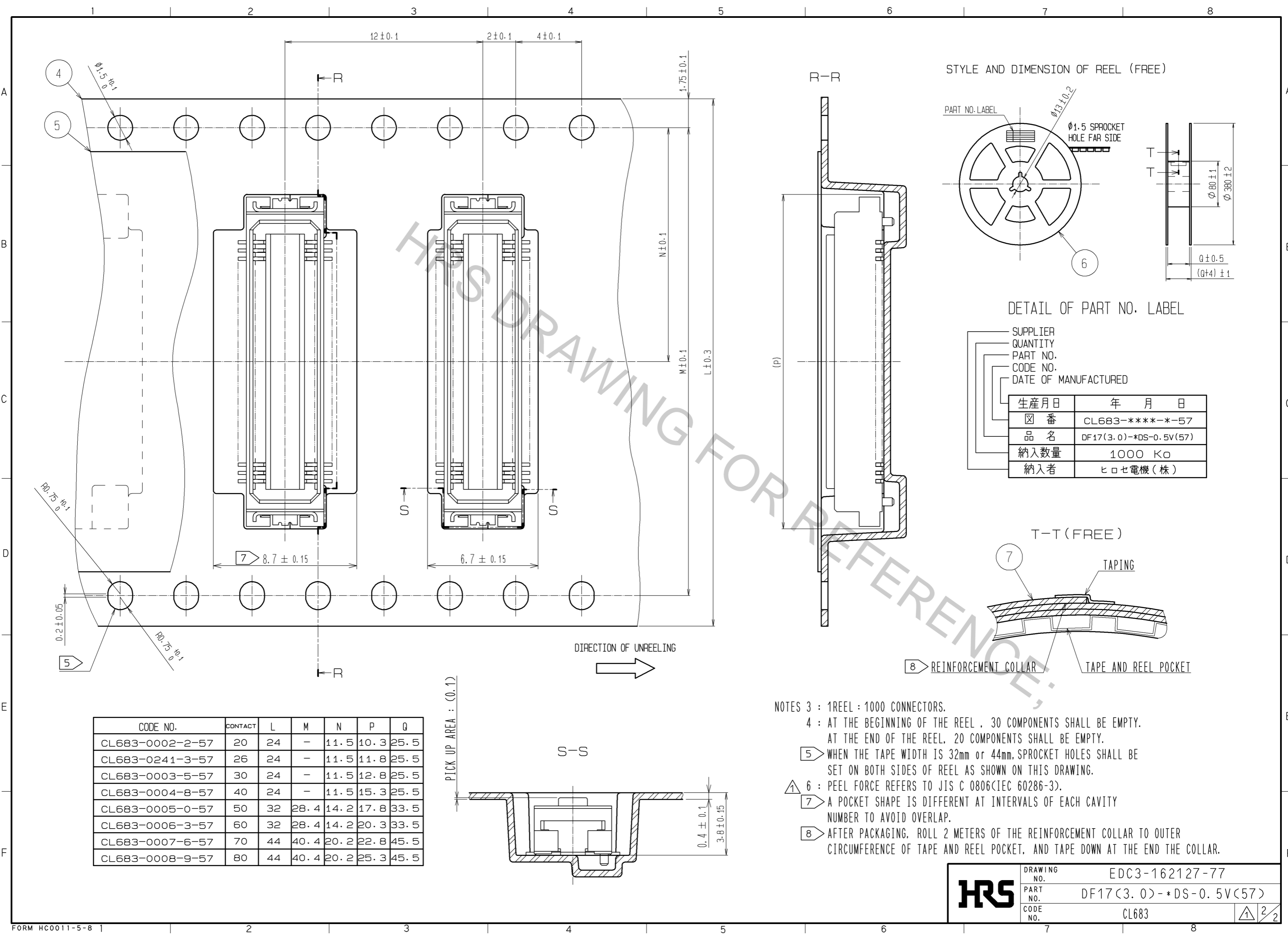

DETAIL OF PART NO. LABEL

SUPPLIER
QUANTITY
PART NO.
CODE NO.
DATE OF MANUFACTURED

生産月日	年 月 日
☒ 番	CL683-****-*57
品名	DF17(3.0)-*DS-0.5V(57)
納入数量	1000 KO
納入者	ヒロセ電機(株)

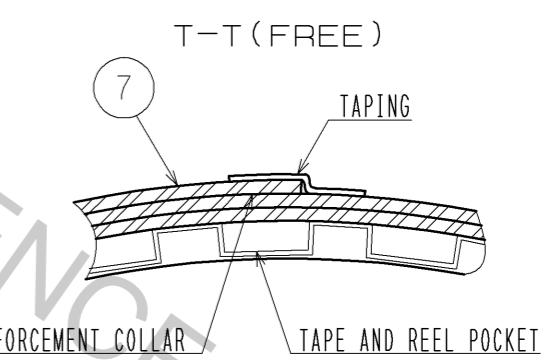

CODE NO.	CONTACT	L	M	N	P	Q
CL683-0002-2-57	20	24	-	11.5	10.3	25.5
CL683-0241-3-57	26	24	-	11.5	11.8	25.5
CL683-0003-5-57	30	24	-	11.5	12.8	25.5
CL683-0004-8-57	40	24	-	11.5	15.3	25.5
CL683-0005-0-57	50	32	28.4	14.2	17.8	33.5
CL683-0006-3-57	60	32	28.4	14.2	20.3	33.5
CL683-0007-6-57	70	44	40.4	20.2	22.8	45.5
CL683-0008-9-57	80	44	40.4	20.2	25.3	45.5

- NOTES 3 : 1REEL : 1000 CONNECTORS.
- 4 : AT THE BEGINNING OF THE REEL , 30 COMPONENTS SHALL BE EMPTY.
AT THE END OF THE REEL, 20 COMPONENTS SHALL BE EMPTY.
- 5 WHEN THE TAPE WIDTH IS 32mm or 44mm, SPROCKET HOLES SHALL BE SET ON BOTH SIDES OF REEL AS SHOWN ON THIS DRAWING.
- 6 : PEEL FORCE REFERS TO JIS C 0806(IEC 60286-3).
- 7 A POCKET SHAPE IS DIFFERENT AT INTERVALS OF EACH CAVITY NUMBER TO AVOID OVERLAP.
- 8 AFTER PACKAGING, ROLL 2 METERS OF THE REINFORCEMENT COLLAR TO OUTER CIRCUMFERENCE OF TAPE AND REEL POCKET, AND TAPE DOWN AT THE END THE COLLAR.

HRS	DRAWING NO.	EDC3-162127-77
	PART NO.	DF17(3.0)-*DS-0.5V(57)
	CODE NO.	CL683