

Aug.1.2016 Copyright 2016 HIROSE ELECTRIC CO., LTD. All Rights Reserved.

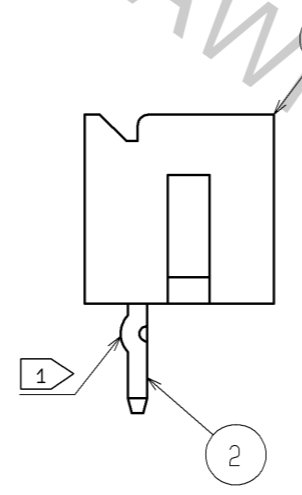

| CODE No. | PART No. | CONTACT | A | B | C |
|--------------|---------------|---------|------|------|------|
| CL543-0165-0 | DF3A- 2P-2DSA | 2 | 6.0 | 4.6 | 2.0 |
| CL543-0166-2 | DF3A- 3P-2DSA | 3 | 8.0 | 6.6 | 4.0 |
| CL543-0167-5 | DF3A- 4P-2DSA | 4 | 10.0 | 8.6 | 6.0 |
| CL543-0168-8 | DF3A- 5P-2DSA | 5 | 12.0 | 10.6 | 8.0 |
| CL543-0169-0 | DF3A- 6P-2DSA | 6 | 14.0 | 12.6 | 10.0 |
| CL543-0170-0 | DF3A- 7P-2DSA | 7 | 16.0 | 14.6 | 12.0 |
| CL543-0171-2 | DF3A- 8P-2DSA | 8 | 18.0 | 16.6 | 14.0 |
| CL543-0172-5 | DF3A- 9P-2DSA | 9 | 20.0 | 18.6 | 16.0 |
| CL543-0173-8 | DF3A-10P-2DSA | 10 | 22.0 | 20.6 | 18.0 |
| CL543-0174-0 | DF3A-11P-2DSA | 11 | 24.0 | 22.6 | 20.0 |
| CL543-0175-3 | DF3A-12P-2DSA | 12 | 26.0 | 24.6 | 22.0 |
| CL543-0176-6 | DF3A-13P-2DSA | 13 | 28.0 | 26.6 | 24.0 |
| CL543-0177-9 | DF3A-14P-2DSA | 14 | 30.0 | 28.6 | 26.0 |
| CL543-0178-1 | DF3A-15P-2DSA | 15 | 32.0 | 30.6 | 28.0 |

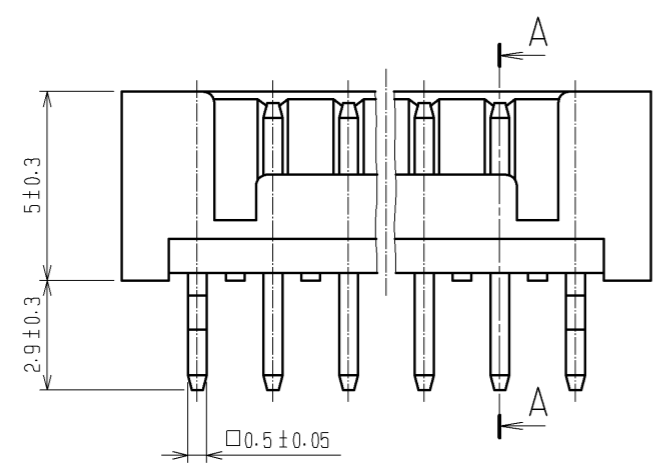
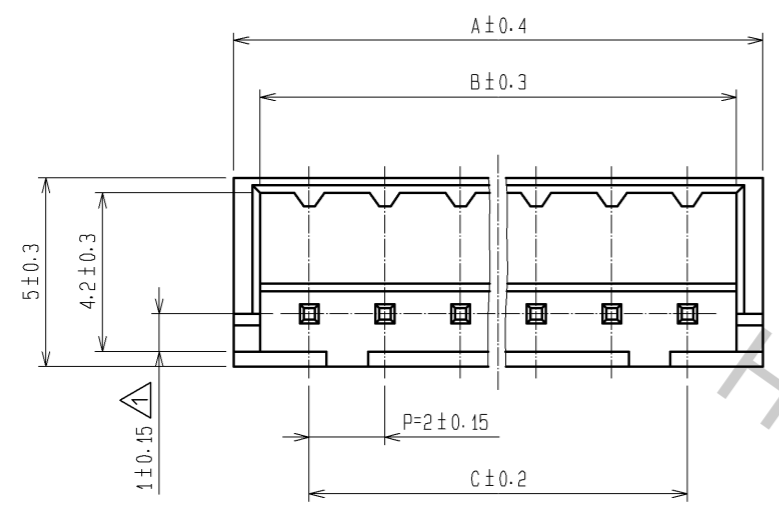
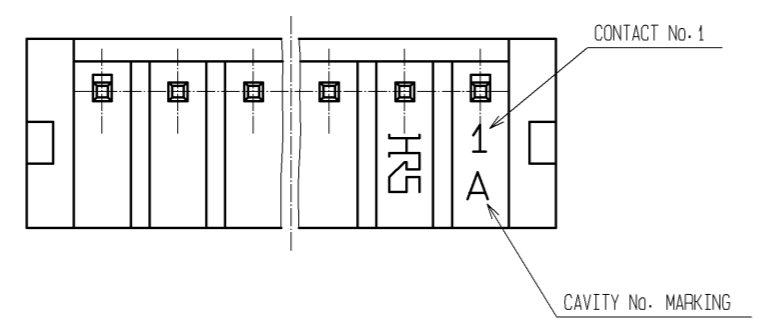
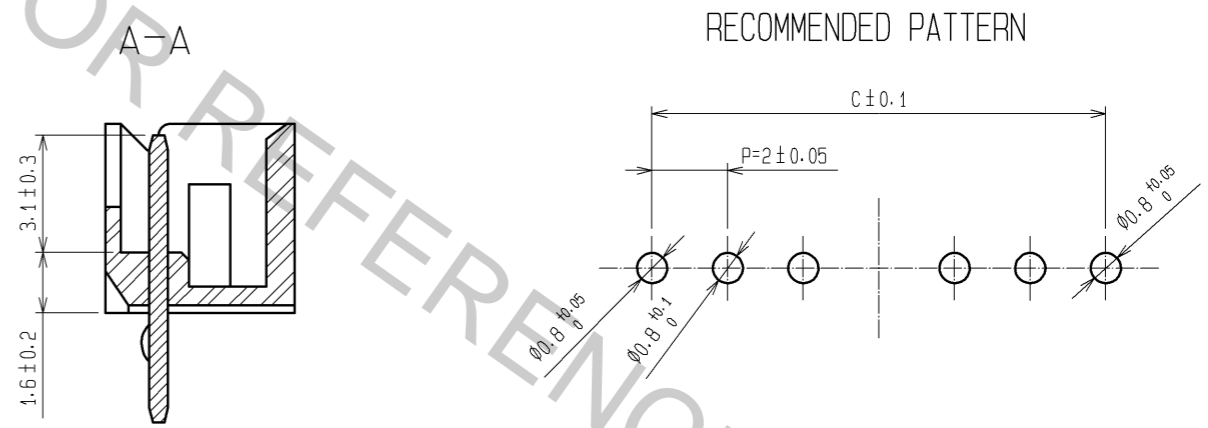

NOTES 1: KINK PROCESSING IS CARRIED OUT TO THE TERMINAL OF BOTH SIDES. (CONTACT No. 1, No. *)

| | | | | | |
|---------------------------|-----------|-------------------------|------------|------------------------------------------|---------------------------------------------------------------------|
| 1 | POLYAMIDE | BLACK, UL94V-0 | 2 | BRASS | SURFACE: TIN PLATED 1μ min UNDER PLATING: NICKEL PLATED 0.5μ min |
| NO. | MATERIAL | FINISH, REMARKS | NO. | MATERIAL | FINISH, REMARKS |
| UNITS mm | | SCALE 5 : 1 | COUNT 1 | DESCRIPTION OF REVISIONS DIS-H-004732 | DESIGNED MI. SAKIMURA |
| | | APPROVED : TY. OMA | 06.08.31 | DRAWING NO. | EDC3-162184-03 |
| HIROSE ELECTRIC CO., LTD. | | CHECKED : HK. UMEHARA | 06.08.31 | PART NO. | DF3A- * P-2DSA |
| | | DESIGNED : TS. KUMAZAWA | 06.08.30 | CODE NO. | CL543 |
| | | DRAWN : AK. MIURA | 06.08.29 | | |