

NO.	MATERIAL	FINISH	REMARKS	NO.	MATERIAL	FINISH	REMARKS
2	PHOSPHOR BRONZE	CONTACT AREA: Au 0.05 μm MIN SMT LEAD: Au 0.05 μm MIN UNDERPLATING: NICKEL 1 μm MIN		6	PS		CLEAR, REINFORCEMENT COLLAR
				5	PS		BLACK, PLASTIC REEL
				4	POLYESTER		CLEAR, COVER TAPE
1	LCP	BLACK, UL94V-0		3	PS		CLEAR, EMBOSSED CARRIER TAPE

UNITS	SCALE	COUNT	DESCRIPTION OF REVISIONS	DESIGNED	CHECKED	DATE
mm	10:1	1				
APPROVED: MO. ISHIDA			15.07.15	DRAWING NO. EDC-337747-51-01		
CHECKED: TS. MIYAZAKI			15.07.15	PART NO. DF40HC(3.5)-80DS-0.4V(51)		
DESIGNED: SH. HOSODA			15.07.15	CODE NO. CL684-4162-7-51		
DRAWN: KR. AJITO			15.07.15	1/2		

EMBOSSED CARRIER TAPE PACKING(FREE)

STYLE AND DIMENSION OF REEL(FREE)

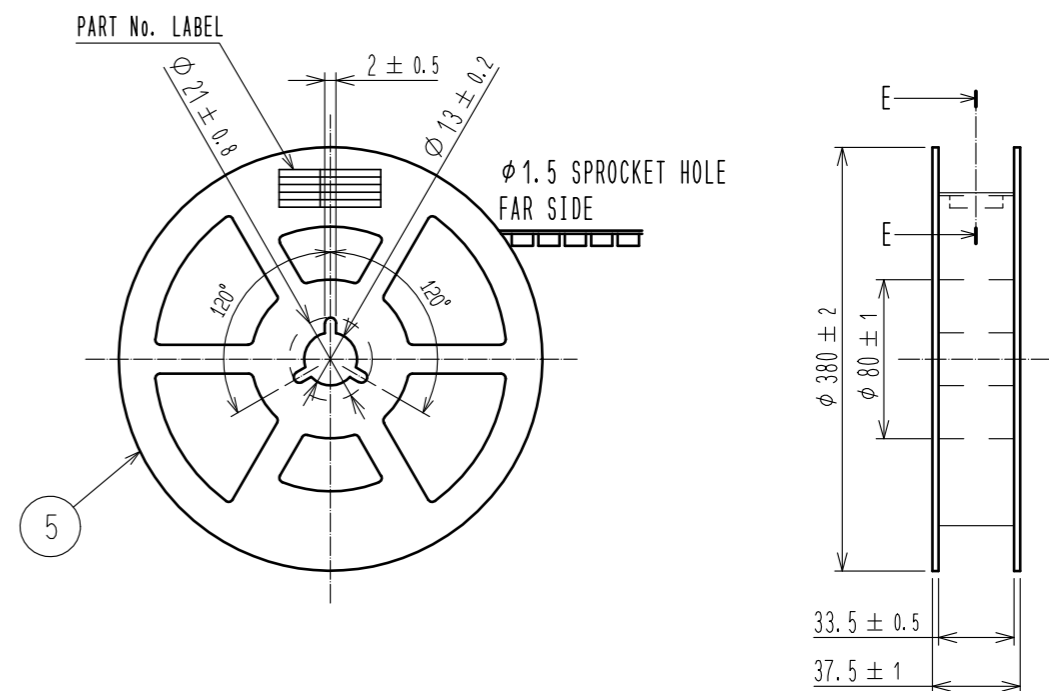
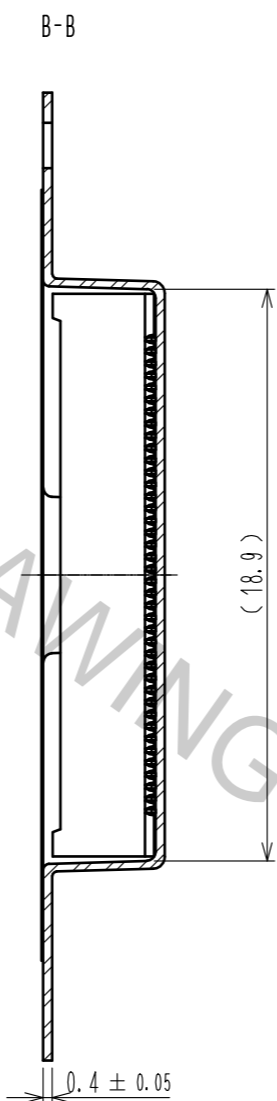
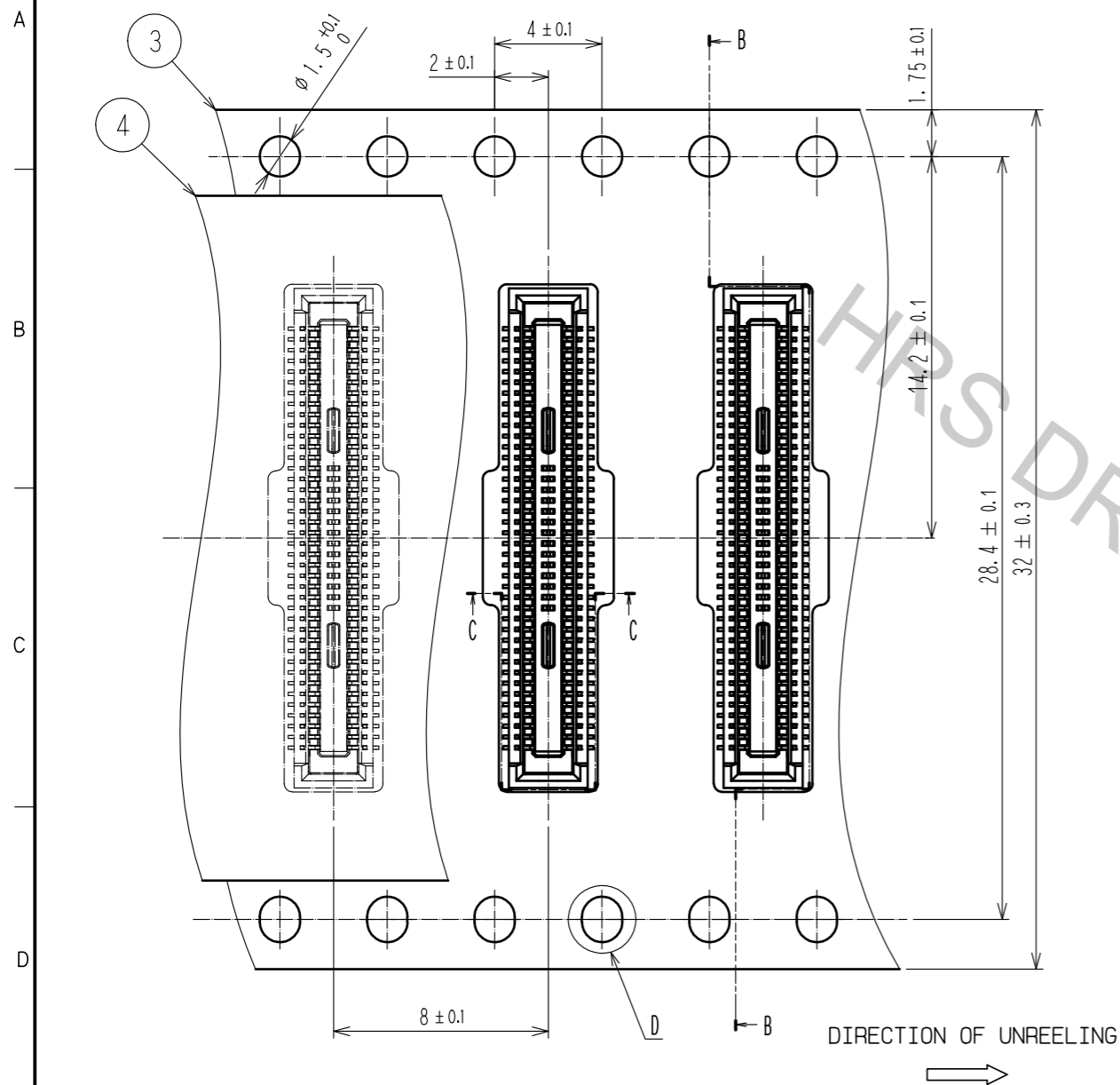

8 DETAIL OF PART No. LABEL

製造年月日	** ** *
製品コード	CL684-4162-7-51
製品名	DF40HC(3.5)-80DS-0.4V(51)
数量	4000
納入者	ヒロセ電機(株)

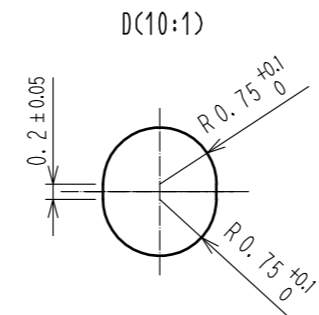
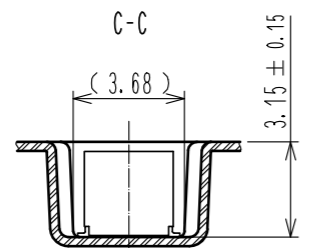
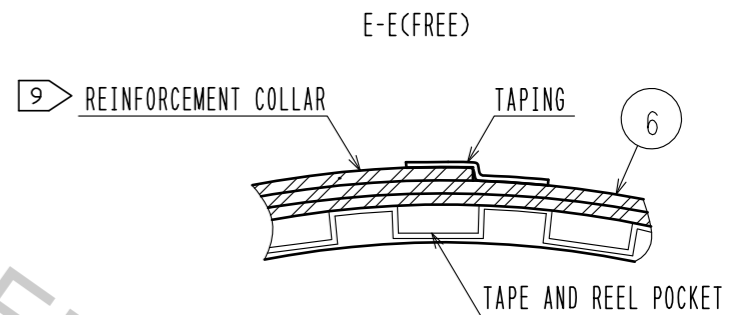

- NOTES
- PER REEL 4000 CONNECTORS.
  - THE DIMENSIONS IN PARENTHESES ARE FOR REFERENCE.
  - REFER TO JIS C 0806, IEC 60286-3 (PACKING OF COMPONENTS FOR AUTOMATIC HANDLING)
  - DETAIL OF PART No. LABEL IS WRITTEN IN JAPANESE. PART No. LABEL DESCRIBES THE FOLLOWING INFORMATION FROM TOP.  
 PRODUCTION DATE:  
 PRODUCT CODE: CL684-4162-7-51  
 PART NUMBER: DF40HC(3.5)-80DS-0.4V(51)  
 NUMBER OF PIECES: 4000 PIECES  
 SUPPLIER NAME: HIROSE ELECTRIC CO., LTD.
  - AFTER PACKAGING, ROLL 2 METERS OF THE REINFORCEMENT COLLAR TO OUTER CIRCUMFERENCE OF TAPE AND REEL POCKET, AND TAPE DOWN AT THE END THE COLLAR.

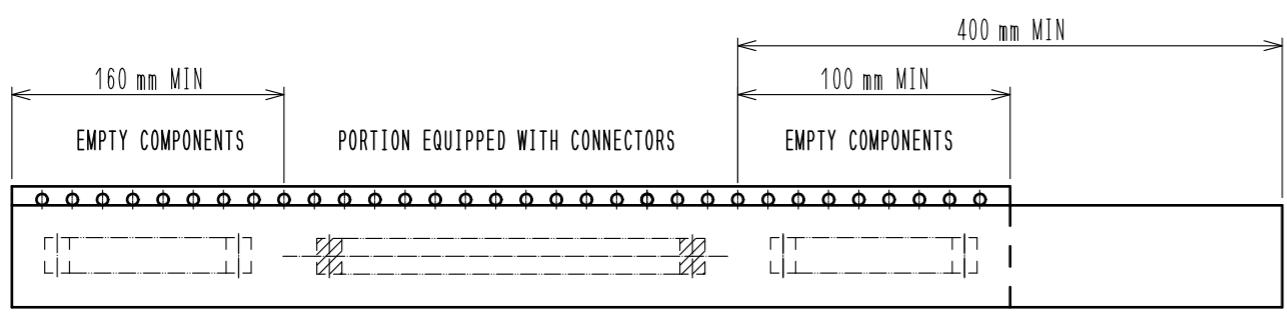

<b>HRS</b>	DRAWING NO.	EDC-337747-51-01
	PART NO.	DF40HC(3.5)-80DS-0.4V(51)
	CODE NO.	CL684-4162-7-51
		2/2

Aug.1.2016 Copyright 2016 HIROSE ELECTRIC CO., LTD. All Rights Reserved.