

Aug.1.2016 Copyright 2016 HIROSE ELECTRIC CO., LTD. All Rights Reserved.

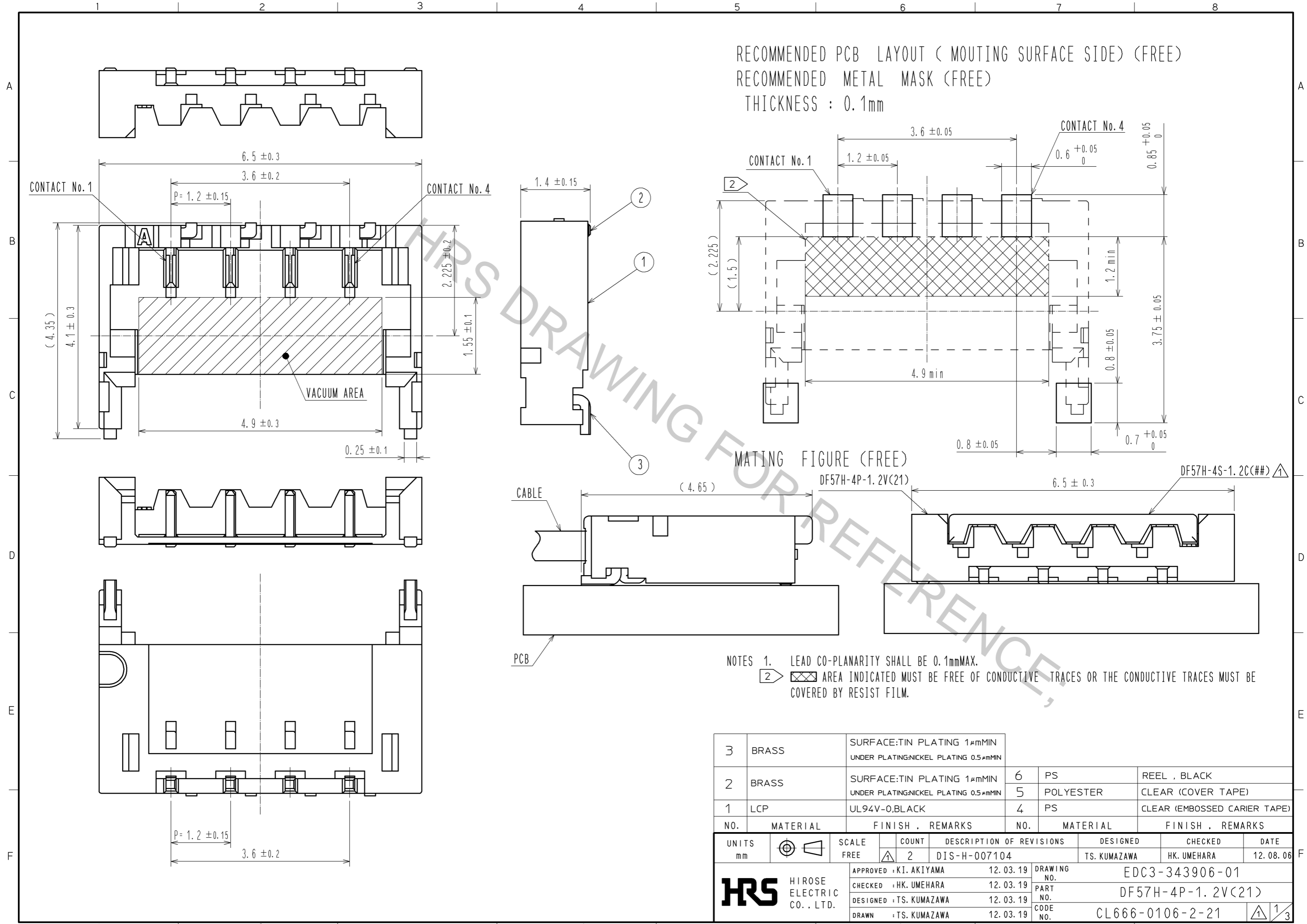

RECOMMENDED PCB LAYOUT (MOUNTING SURFACE SIDE) (FREE)
 RECOMMENDED METAL MASK (FREE)
 THICKNESS : 0.1mm

MATING FIGURE (FREE)

- NOTES 1. LEAD CO-PLANARITY SHALL BE 0.1mmMAX.
 2. AREA INDICATED MUST BE FREE OF CONDUCTIVE TRACES OR THE CONDUCTIVE TRACES MUST BE COVERED BY RESIST FILM.

NO.	MATERIAL	FINISH . REMARKS	NO.	MATERIAL	FINISH . REMARKS
3	BRASS	SURFACE:TIN PLATING 1μmMIN UNDER PLATING:NICKEL PLATING 0.5μmMIN	6	PS	REEL , BLACK
2	BRASS	SURFACE:TIN PLATING 1μmMIN UNDER PLATING:NICKEL PLATING 0.5μmMIN	5	POLYESTER	CLEAR (COVER TAPE)
1	LCP	UL94V-0,BLACK	4	PS	CLEAR (EMBOSSD CARRIER TAPE)

UNITS	SCALE	COUNT	DESCRIPTION OF REVISIONS	DESIGNED	CHECKED	DATE
mm	FREE	2	DIS-H-007104	TS. KUMAZAWA	HK. UMEHARA	12. 08. 06

APPROVED	CHECKED	DESIGNED	DRAWN	DRAWING NO.	PART NO.	CODE NO.
KI. AKIYAMA	HK. UMEHARA	TS. KUMAZAWA	TS. KUMAZAWA	EDC3-343906-01	DF57H-4P-1. 2V(21)	CL666-0106-2-21
12. 03. 19	12. 03. 19	12. 03. 19	12. 03. 19			

Aug.1.2016 Copyright 2016 HIROSE ELECTRIC CO., LTD. All Rights Reserved.

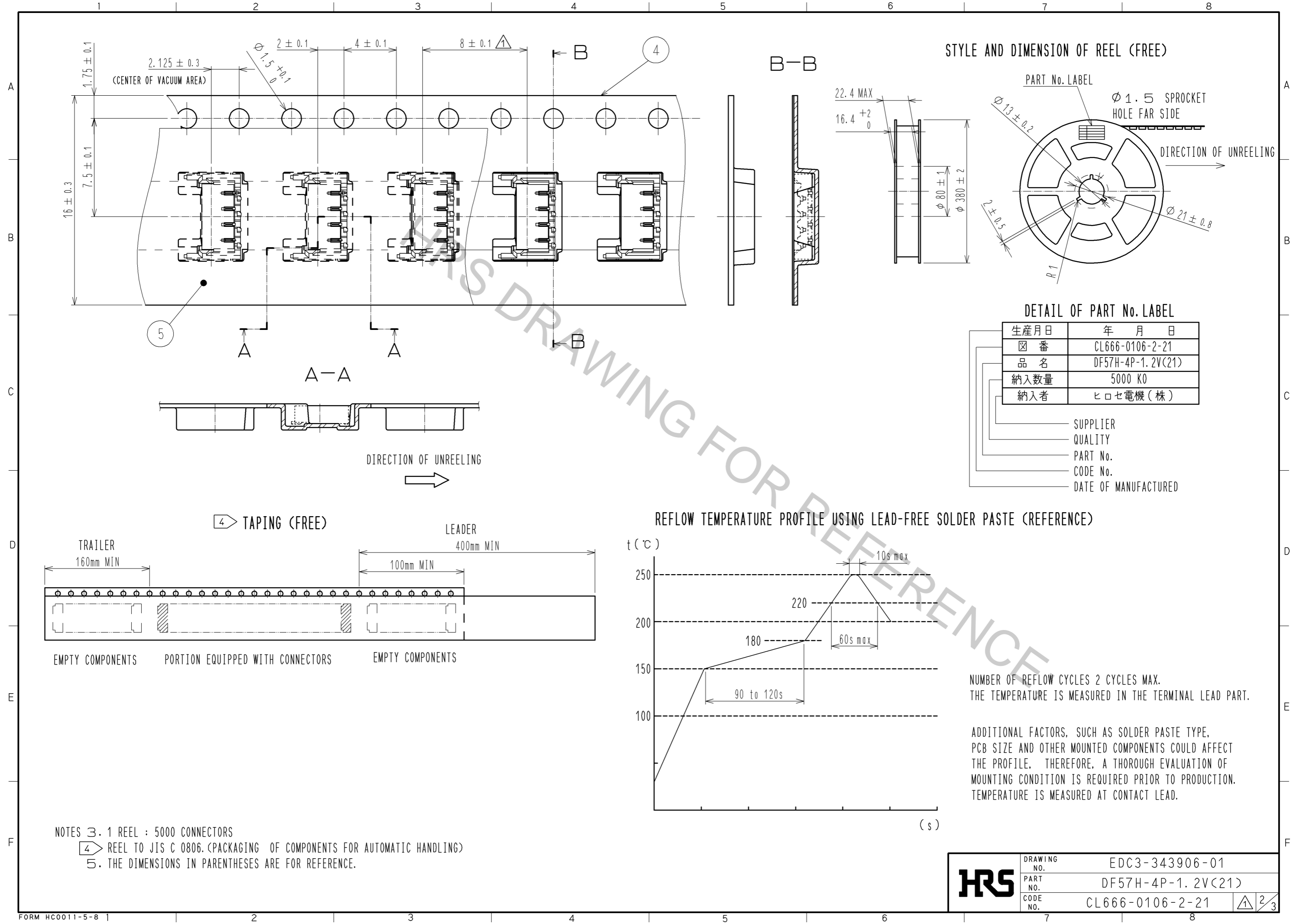

STYLE AND DIMENSION OF REEL (FREE)

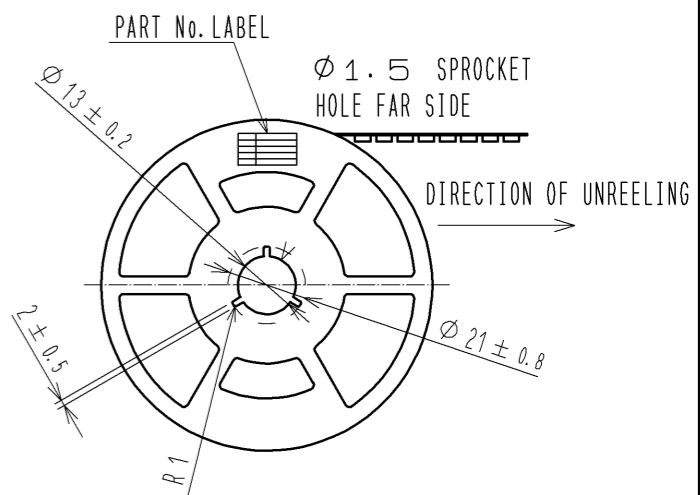

DETAIL OF PART No. LABEL

生産月日	年 月 日
図 番	CL666-0106-2-21
品 名	DF57H-4P-1.2V(21)
納入数量	5000 KO
納入者	ヒロセ電機(株)

- SUPPLIER
- QUALITY
- PART No.
- CODE No.
- DATE OF MANUFACTURED

REFLOW TEMPERATURE PROFILE USING LEAD-FREE SOLDER PASTE (REFERENCE)

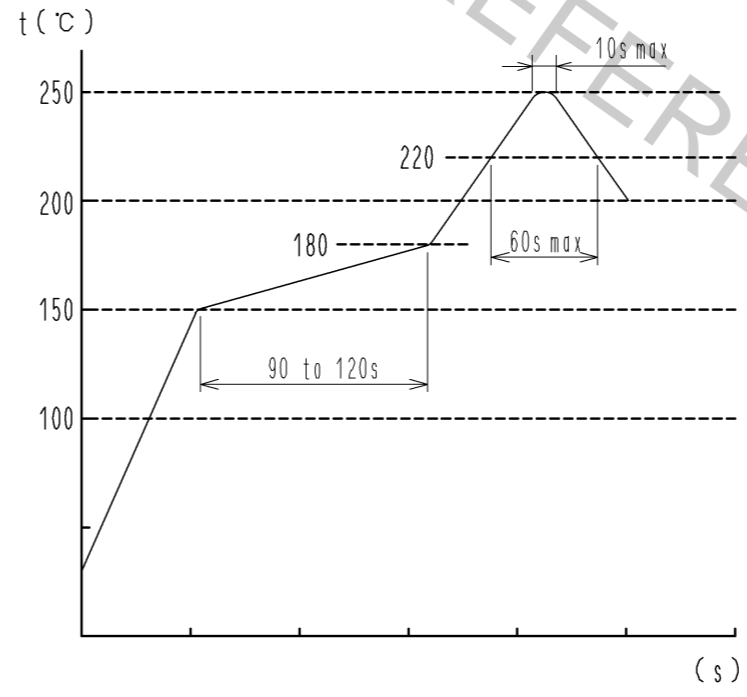

NUMBER OF REFLOW CYCLES 2 CYCLES MAX.
THE TEMPERATURE IS MEASURED IN THE TERMINAL LEAD PART.

ADDITIONAL FACTORS, SUCH AS SOLDER PASTE TYPE, PCB SIZE AND OTHER MOUNTED COMPONENTS COULD AFFECT THE PROFILE. THEREFORE, A THOROUGH EVALUATION OF MOUNTING CONDITION IS REQUIRED PRIOR TO PRODUCTION. TEMPERATURE IS MEASURED AT CONTACT LEAD.

- NOTES
- 1 REEL : 5000 CONNECTORS
 - 2 REEL TO JIS C 0806. (PACKAGING OF COMPONENTS FOR AUTOMATIC HANDLING)
 - 3 THE DIMENSIONS IN PARENTHESES ARE FOR REFERENCE.

HRS	DRAWING NO.	EDC3-343906-01
	PART NO.	DF57H-4P-1.2V(21)
	CODE NO.	CL666-0106-2-21
		\triangle 2/3

DF57 Series Mating / Unmating Operation Instruction

Mating

① By positioning the convexity of the socket sides to the header concavity, align the centers of the socket and the header in pitch direction.

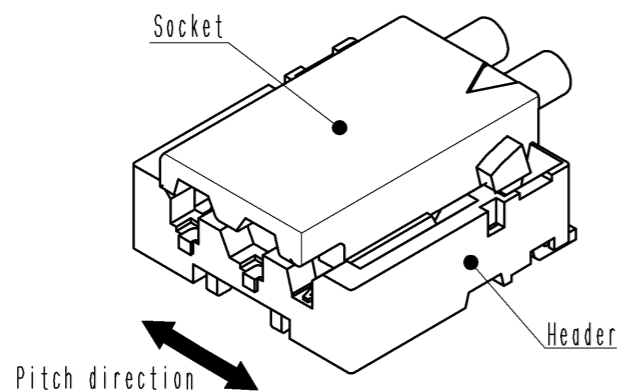

② Slightly press the socket down at cable side to tilted angle.

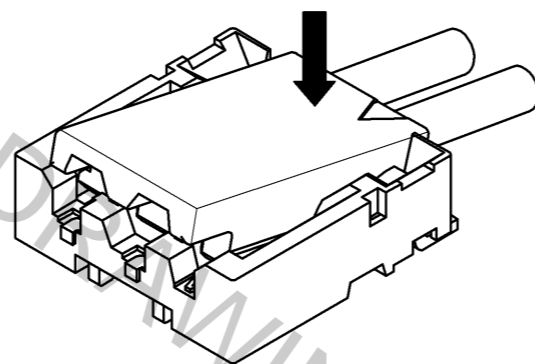

③ Press down at the lever side with stabilizing the cable side to insert. Mating completes.

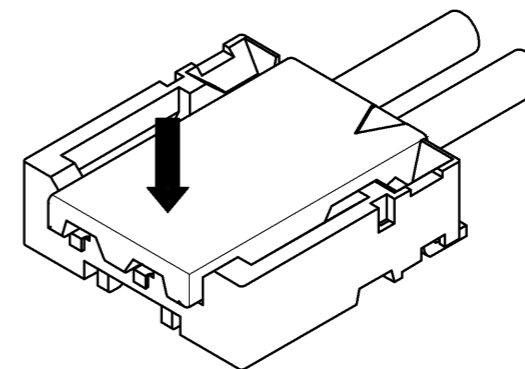

Unmating

① Hook the lever with finger nail.

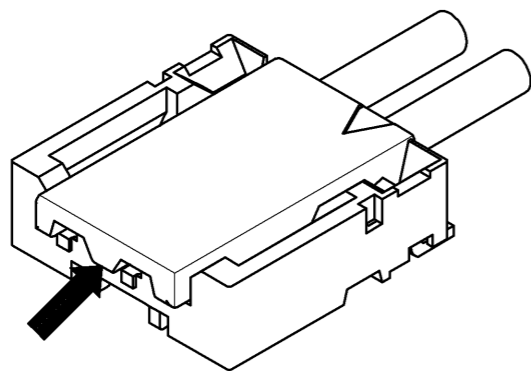

② Lift up to the upper direction and friction lock is released.

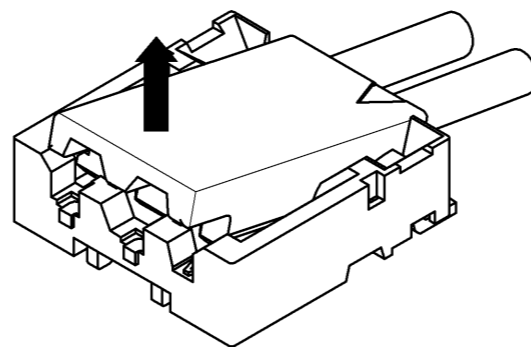

③ Lift up to the upper direction and positive lock is released. Removal completes.

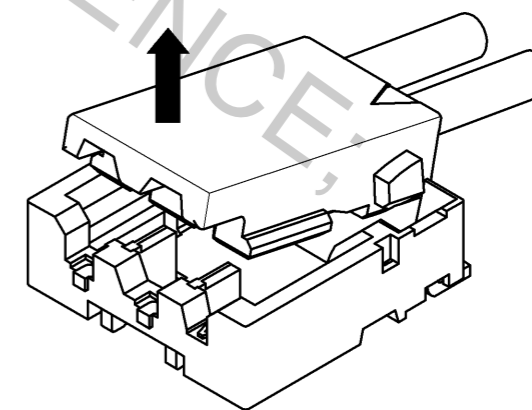

HRS	DRAWING NO.	EDC3-343906-01	
	PART NO.	DF57H-4P-1.2V(21)	
	CODE NO.	CL666-0106-2-21	

Aug.1.2016 Copyright 2016 HIROSE ELECTRIC CO., LTD. All Rights Reserved.