

Aug.1.2016 Copyright 2016 HIROSE ELECTRIC CO., LTD. All Rights Reserved.

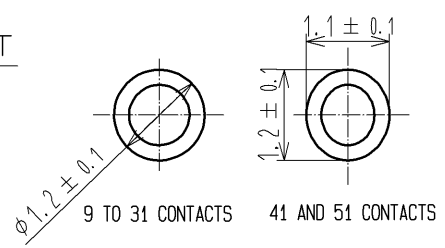

RECOMMENDED PATTERN

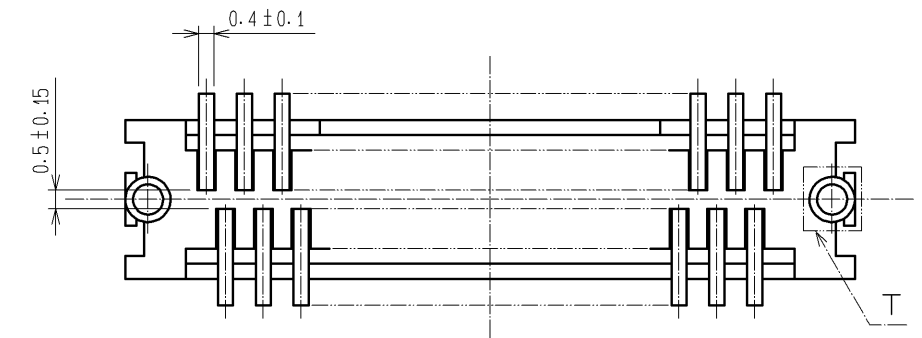
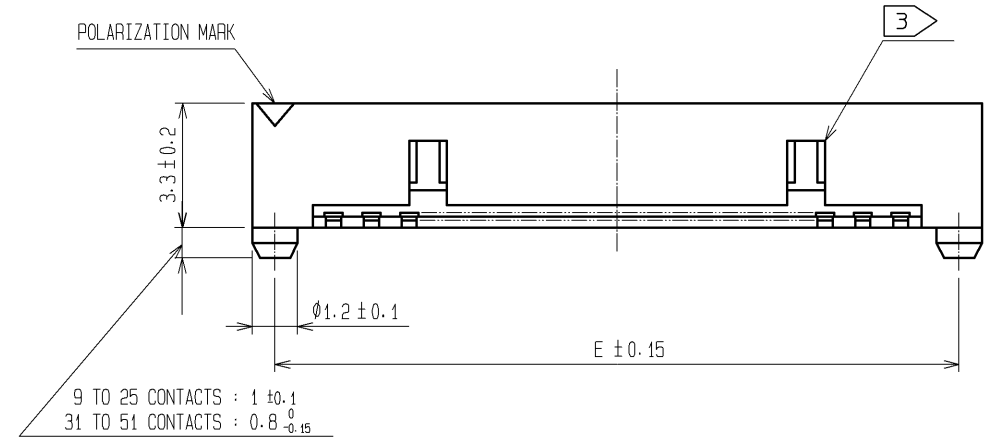
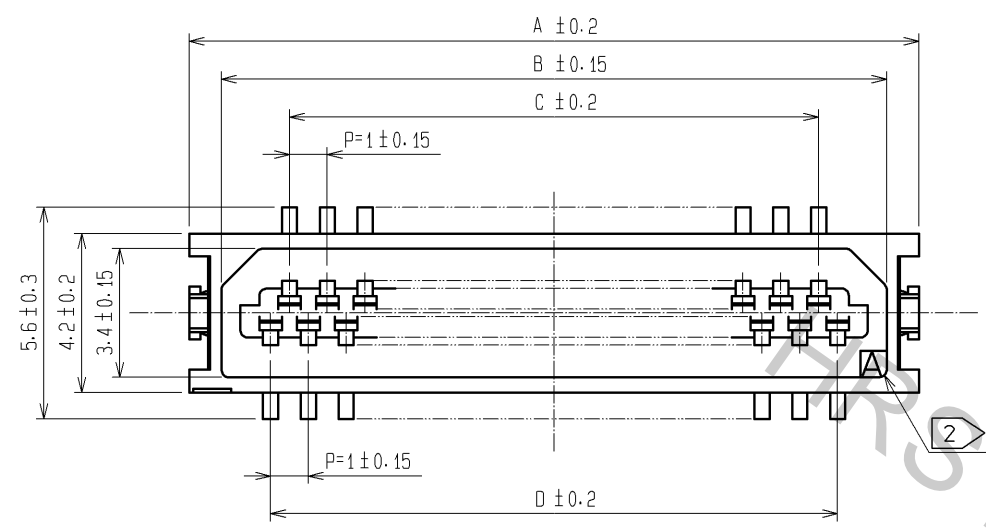
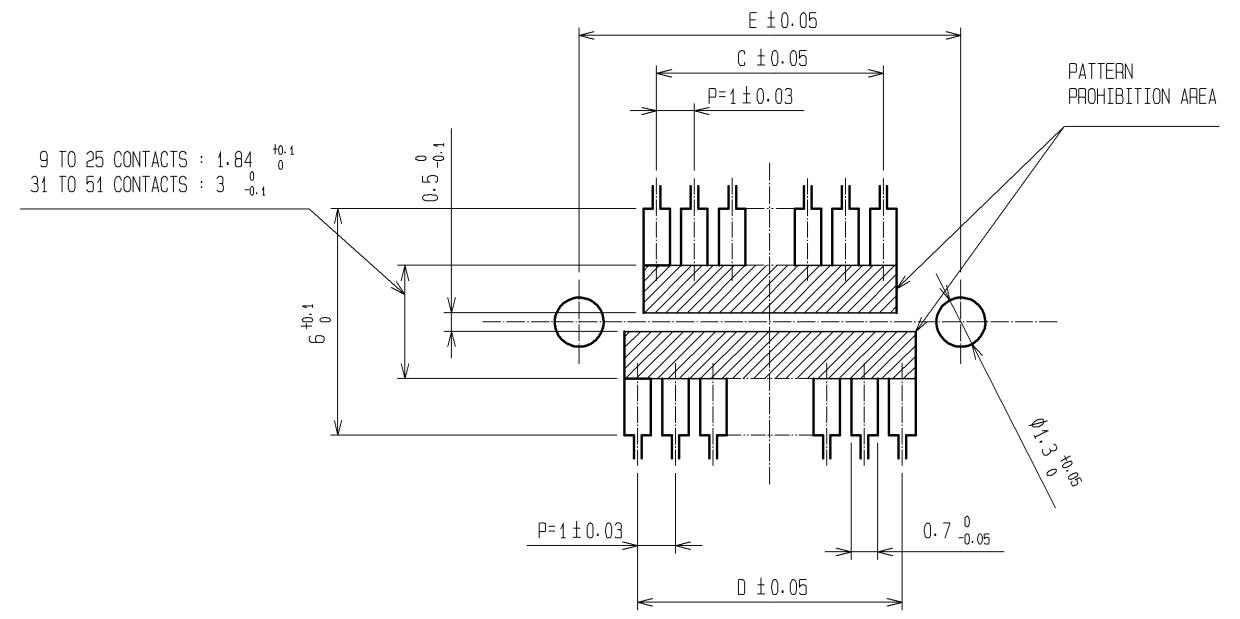

PART No.	CODE No.	NUMBER OF CONTACTS	A	B	C	D	E
DF9A-9P-1V(22)	CL540-0016-0-22	9	8.3	6.6	3	4	7.1
DF9A-11P-1V(22)	CL540-0017-3-22	11	9.3	7.6	4	5	8.1
DF9A-13P-1V(22)	CL540-0018-6-22	13	10.3	8.6	5	6	9.1
DF9A-15P-1V(22)	CL540-0019-9-22	15	11.3	9.6	6	7	10.1
DF9A-17P-1V(22)	CL540-0020-8-22	17	12.3	10.6	7	8	11.1
DF9A-19P-1V(22)	CL540-0021-0-22	19	13.3	11.6	8	9	12.1
DF9A-21P-1V(22)	CL540-0022-3-22	21	14.3	12.6	9	10	13.1
DF9A-23P-1V(22)	CL540-0023-6-22	23	15.3	13.6	10	11	14.1
DF9A-25P-1V(22)	CL540-0024-9-22	25	16.3	14.6	11	12	15.1
DF9A-31P-1V(22)	CL540-0025-1-22	31	19.3	17.6	14	15	18.1
DF9A-41P-1V(22)	CL540-0223-5-22	41	24.3	22.6	19	20	23.1
DF9A-51P-1V(22)	-	51	29.3	27.6	24	25	28.1

NOTES 1 : LEAD CO-PLANARITY INCLUDE REINFORCED METAL FITTINGS SHALL BE 0.1mm MAX.
 ② HRS MARK AND CAV NO. ARE INDICATED IN APPROX POSITION SHOWN.
 ③ 9 TO 25 CONTACT CONNECTORS HAVE ONE LOCK AT CENTER OF HOUSING.
 31 TO 51 CONTACT CONNECTORS HAVE TWO LOCKS AS PER DRAWING.

NO.	MATERIAL	FINISH . REMARKS	NO.	MATERIAL	FINISH . REMARKS
3	PS	CLEAR(EMBOSSED CARRIER TAPE)	7	PS	REINFORCEMENT COLLAR
2	PHOSPHOR BRONZE	TIN PLATED(HOT DIP) 1μm min	6	PS	BLACK(PLASTIC REEL)
1	POLYAMIDE	BEIGE. UL94V-0	5	POLYIMIDE	BROWN(HEAT-RESISTANCE TAPE)
			4	POLYESTER	CLEAR(COVER TAPE)

UNITS	SCALE	COUNT	DESCRIPTION OF REVISIONS	DESIGNED	CHECKED	DATE
mm	5 : 1	△				

APPROVED : KH. IKEDA	12.02.01	DRAWING NO.	EDC3-306115-02
CHECKED : AR. TAKAHASHI	12.02.01	PART NO.	DF9A-*P-1V(22)
DESIGNED : SH. HOSODA	12.02.01	CODE NO.	CL540-
DRAWN : KT. IWAMA	12.02.01		

Aug.1.2016 Copyright 2016 HIROSE ELECTRIC CO., LTD. All Rights Reserved.

STYLE AND DIMENSION OF REEL (FREE)

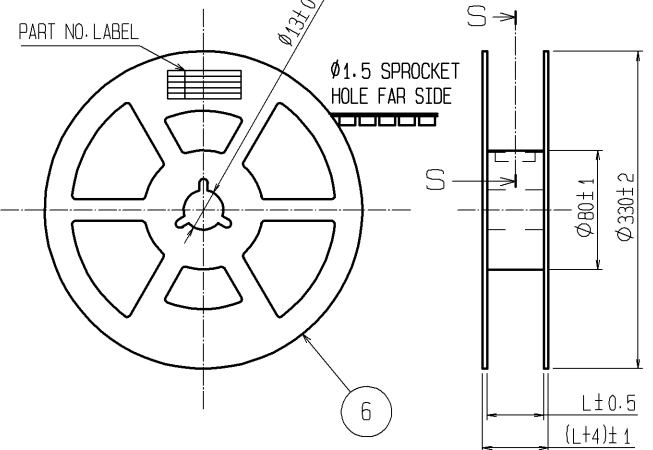
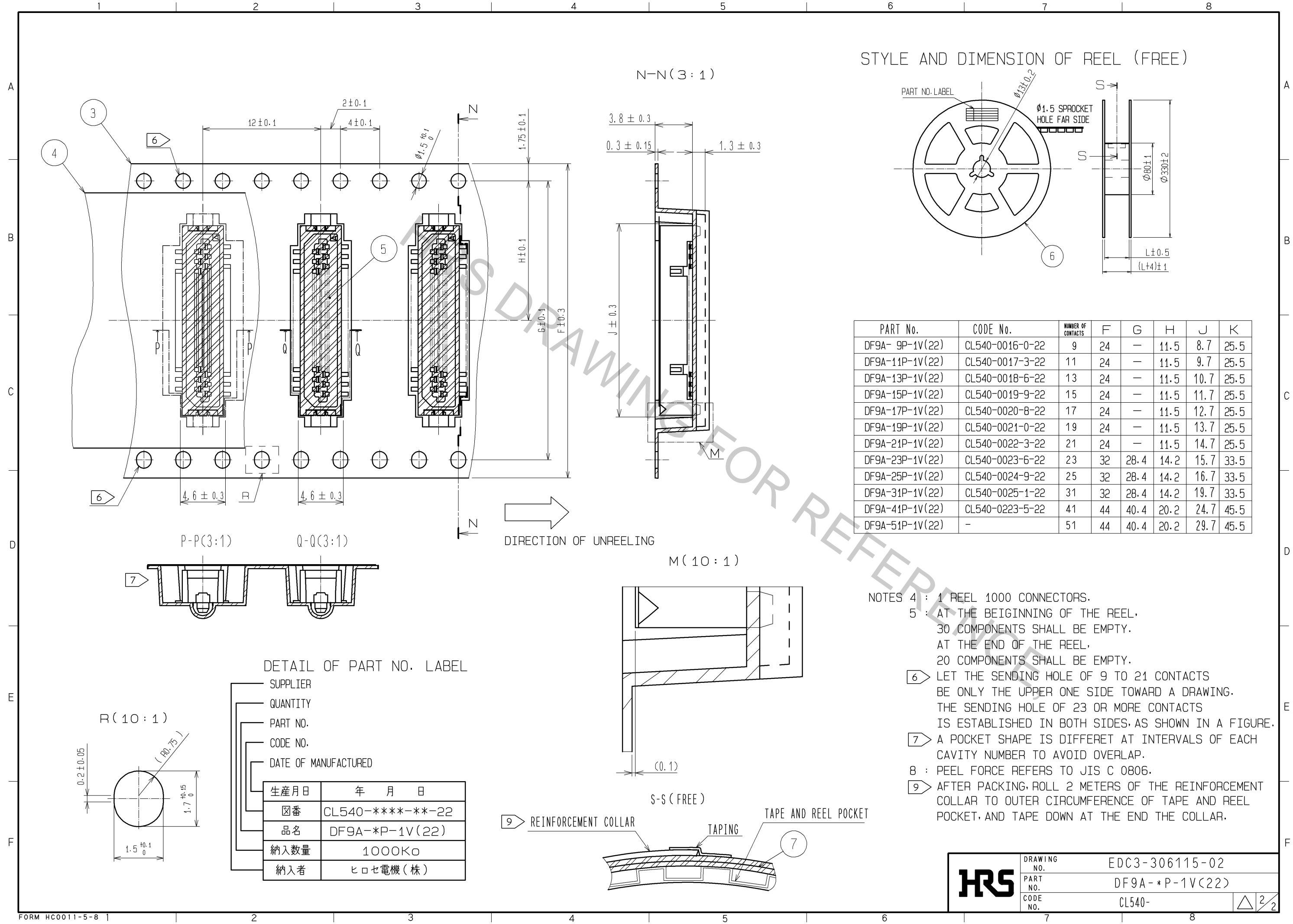

PART No.	CODE No.	NUMBER OF CONTACTS	F	G	H	J	K
DF9A-9P-1V(22)	CL540-0016-0-22	9	24	-	11.5	8.7	25.5
DF9A-11P-1V(22)	CL540-0017-3-22	11	24	-	11.5	9.7	25.5
DF9A-13P-1V(22)	CL540-0018-6-22	13	24	-	11.5	10.7	25.5
DF9A-15P-1V(22)	CL540-0019-9-22	15	24	-	11.5	11.7	25.5
DF9A-17P-1V(22)	CL540-0020-8-22	17	24	-	11.5	12.7	25.5
DF9A-19P-1V(22)	CL540-0021-0-22	19	24	-	11.5	13.7	25.5
DF9A-21P-1V(22)	CL540-0022-3-22	21	24	-	11.5	14.7	25.5
DF9A-23P-1V(22)	CL540-0023-6-22	23	32	28.4	14.2	15.7	33.5
DF9A-25P-1V(22)	CL540-0024-9-22	25	32	28.4	14.2	16.7	33.5
DF9A-31P-1V(22)	CL540-0025-1-22	31	32	28.4	14.2	19.7	33.5
DF9A-41P-1V(22)	CL540-0223-5-22	41	44	40.4	20.2	24.7	45.5
DF9A-51P-1V(22)	-	51	44	40.4	20.2	29.7	45.5

- NOTES
- 4 : 1 REEL 1000 CONNECTORS.
 - 5 : AT THE BEIGINNING OF THE REEL, 30 COMPONENTS SHALL BE EMPTY. AT THE END OF THE REEL, 20 COMPONENTS SHALL BE EMPTY.
 - 6 LET THE SENDING HOLE OF 9 TO 21 CONTACTS BE ONLY THE UPPER ONE SIDE TOWARD A DRAWING. THE SENDING HOLE OF 23 OR MORE CONTACTS IS ESTABLISHED IN BOTH SIDES, AS SHOWN IN A FIGURE.
 - 7 A POCKET SHAPE IS DIFFERET AT INTERVALS OF EACH CAVITY NUMBER TO AVOID OVERLAP.
 - 8 : PEEL FORCE REFERS TO JIS C 0806.
 - 9 AFTER PACKING, ROLL 2 METERS OF THE REINFORCEMENT COLLAR TO OUTER CIRCUMFERENCE OF TAPE AND REEL POCKET, AND TAPE DOWN AT THE END THE COLLAR.

DETAIL OF PART NO. LABEL

SUPPLIER	
QUANTITY	
PART NO.	
CODE NO.	
DATE OF MANUFACTURED	
生産月日	年 月 日
図番	CL540-****-**-22
品名	DF9A-*P-1V(22)
納入数量	1000K ϕ
納入者	ヒロセ電機(株)

HRS	DRAWING NO.	EDC3-306115-02
	PART NO.	DF9A-*P-1V(22)
	CODE NO.	CL540-