

RECOMMENDED LAND PATTERN DIMENSION OF PCB  
(RECOMMENDED METAL MASK THICKNESS: 0.15mm)

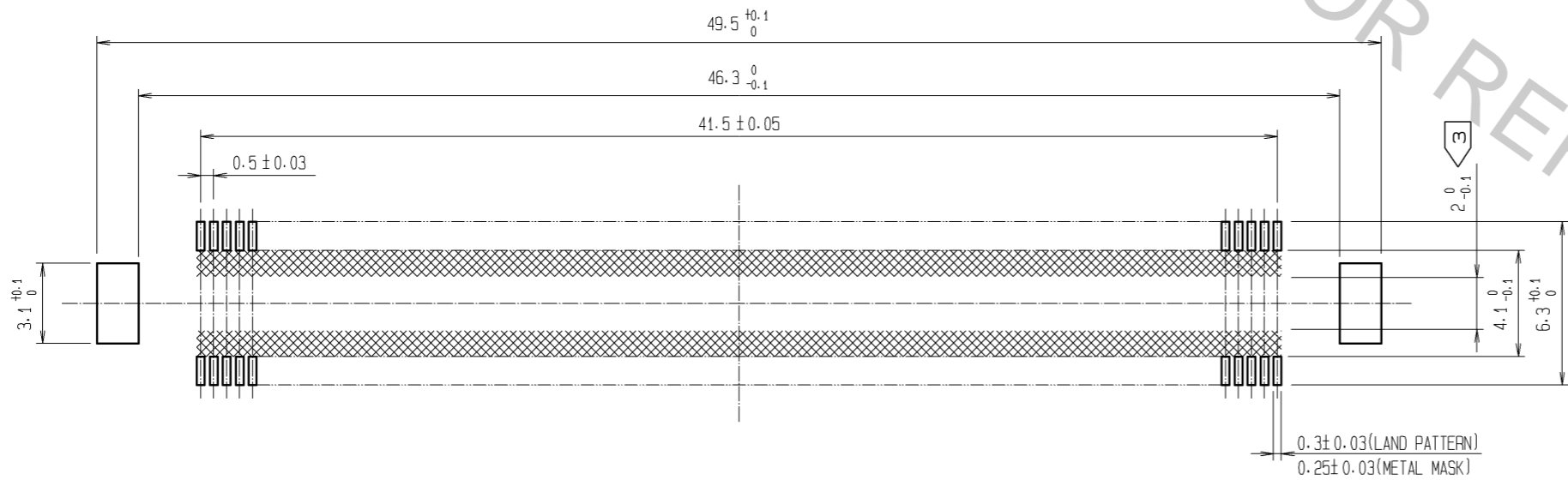

- NOTES
- 1 SMT LEAD-COPLANARITY: 0.1 MAX.
  - 2 THIS PRODUCT HAS NO POLARITY TO PATTERN FOR MOUNTING.
  - 3 MAKE SURE WIDTH OF PATTERN IS WITHIN THAT OF LAND, OR LEAD MAY TOUCH PATTERN. (THIS APPLIES TO HATCHED AREA.)
  - 4 EMBOSS CARRIER TAPE PACKAGE IS APPLIED ON THIS PRODUCT. PLEASE REFER TO THE SHEET 2/2 FOR THE DETAILS.
  - 5 THE DIMENSIONS IN PARENTHESES ARE FOR REFERENCE.

3	PHOSPHOR BRONZE	TIN-PLATING							
2	PHOSPHOR BRONZE	CONTACT AREA: GOLD 0.1µm min. LEAD AREA: TIN-PLATING 1µm min. UNDER PLATING: NICKEL 1µm min.	5	POLYESTER	TOP COVER TAPE				
1	LCP	BEIGE UL94V-0	4	POLYSTYRENE	EMBOSSED CARRIER TAPE				
NO.	MATERIAL	FINISH	REMARKS	NO.	MATERIAL	FINISH	REMARKS		
UNITS		mm	SCALE	4 : 1	COUNT	DESCRIPTION OF REVISIONS	DESIGNED	CHECKED	DATE
<b>HRS</b> HIROSE ELECTRIC CO., LTD.		APPROVED	: HT. YAMAGUCHI	10.07.29	DRAWING NO.	EDC3-151975-21			
		CHECKED	: HT. YAMAGUCHI	10.07.29	PART NO.	FX10B-168P-SV1(91)			
		DESIGNED	: SY. KAMIGA	10.07.29	CODE NO.	CL570-0154-6-91			
		DRAWN	: HK. SUNADORI	10.07.28					

# DRAWING FOR PACKING(2:1)

REELED DIMENSION(Free)

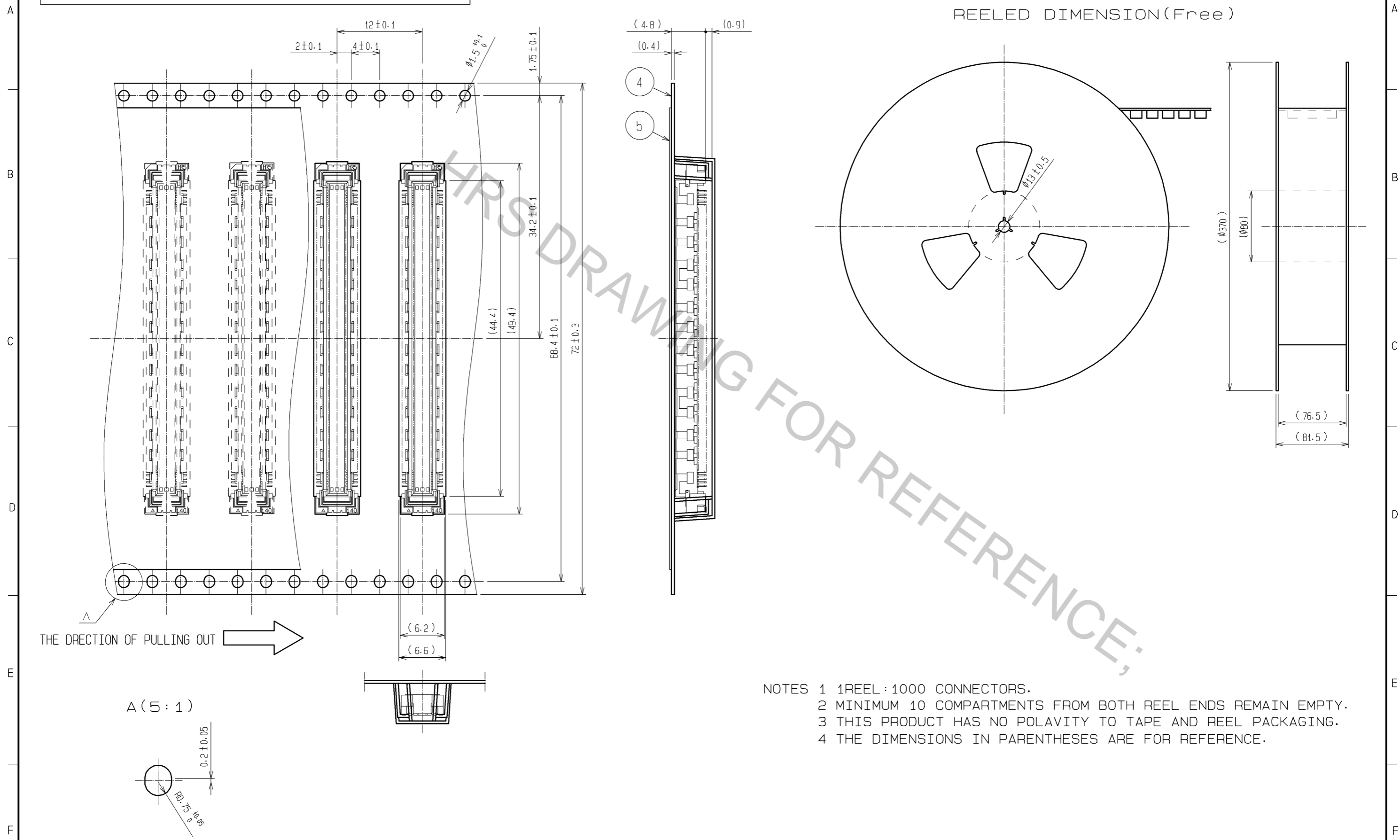

THE DIRECTION OF PULLING OUT →

- NOTES
- 1 REEL : 1000 CONNECTORS.
  - 2 MINIMUM 10 COMPARTMENTS FROM BOTH REEL ENDS REMAIN EMPTY.
  - 3 THIS PRODUCT HAS NO POLARITY TO TAPE AND REEL PACKAGING.
  - 4 THE DIMENSIONS IN PARENTHESES ARE FOR REFERENCE.

<b>HRS</b>	DRAWING NO.	EDC3-151975-21
	PART NO.	FX10B-168P-SV1(91)
	CODE NO.	CL570-0154-6-91
		△ 2/2

Aug.1.2016 Copyright 2016 HIROSE ELECTRIC CO., LTD. All Rights Reserved.