

Aug.1.2016 Copyright 2016 HIROSE ELECTRIC CO., LTD. All Rights Reserved.

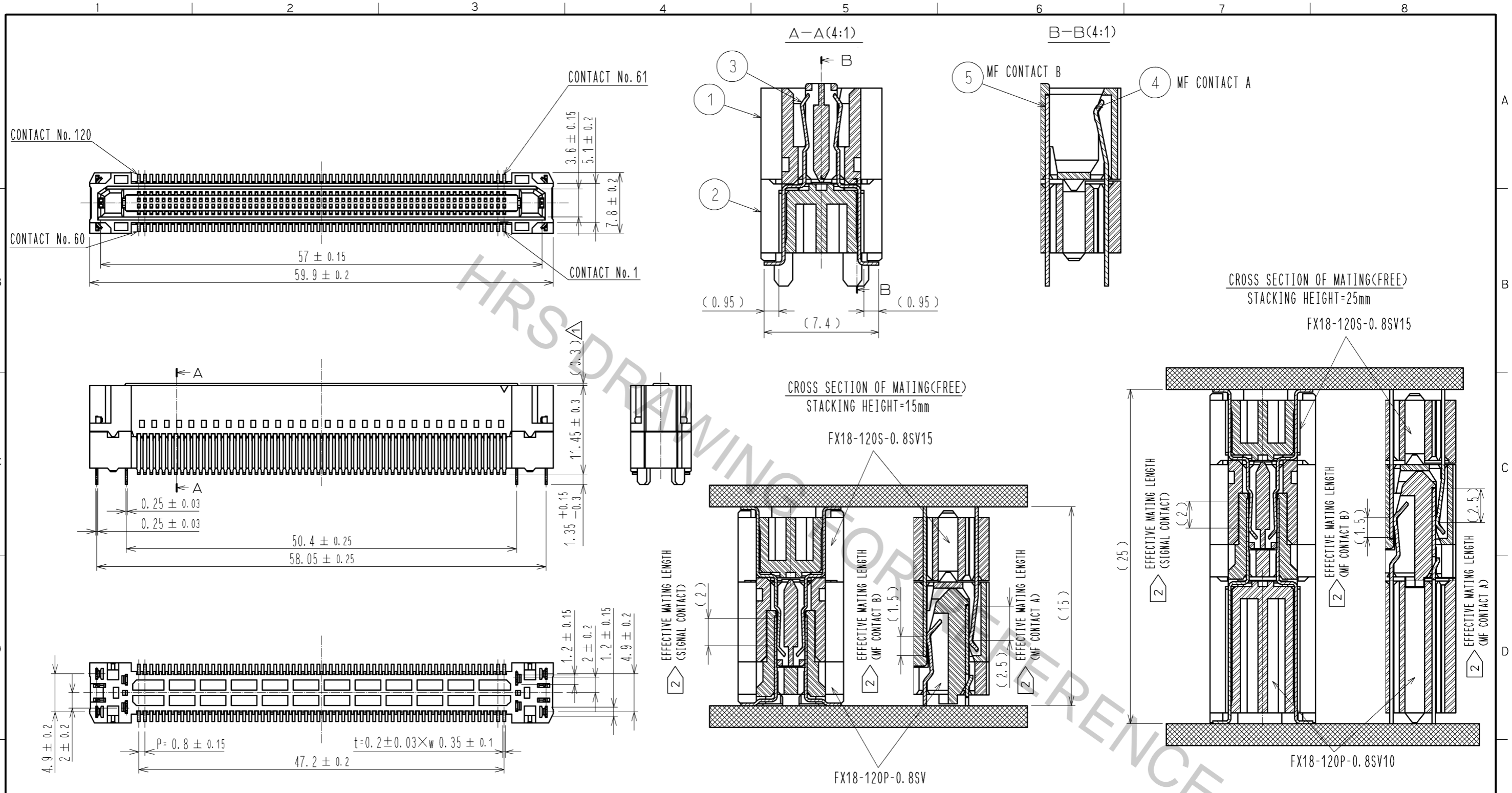

NOTE 1 LEAD CO—PLANARITY IS 0.1mm MAX.
 2 CONTACTS ARE 3 STEPS SEQUENTIAL. (MF CONTACT A=>SIGNAL CONTACT=>MF CONTACT B) WHEN USING THIS SEQUENTIAL STRUCTURE, PLEASE AVOID ANGLED INSERTION.
 3 MF CONTACT A AND MF CONTACT B CAN BE USED AS POWER SUPPLY CONTACT. (3A/PIN MAX)
 4 IT SHOWS THE VACUUM PICKUP AREA. (SEE PAGE 2) REMOVE THE MYLAR TAPE BEFORE MATING CONNECTORS.
 5 THIS IS PACKAGED IN TRAY. (40pcs/TRAY)
 6 BLEMISH AND HIT MARK CAN BE OCCURED THROUGH OUT THE MANUFACTURING PROCESS WHICH DOESN' T AFFECT QUALITY LEVEL.
 7 THE DIMENSIONS IN PARENTHESES ARE FOR REFERENCES.

NO.	MATERIAL	FINISH	REMARKS	NO.	MATERIAL	FINISH	REMARKS
3	PHOSPHOR BRONZE		CONTACT AREA:GOLD 0.1 μm LEAD AREA:GOLD 0.03 μm UNDER PLATING:NICKEL 1.3 μm	5	COPPER ALLOY		CONTACT AREA:GOLD 0.1 μm LEAD AREA:TIN-PLATING 1 μm UNDER PLATING:NICKEL 1.3 μm
2	POLYAMIDE	BLACK	UL94V-0	4	COPPER ALLOY		CONTACT AREA:GOLD 0.1 μm LEAD AREA:TIN-PLATING 1 μm UNDER PLATING:NICKEL 1.3 μm
1	POLYAMIDE	BLACK	UL94V-0				

UNITS	SCALE	COUNT	DESCRIPTION OF REVISIONS	DESIGNED	CHECKED	DATE
mm	2 : 1	4	DIS-F-005578	TH. SANO	KI. HIROKAWA	11.07.21

APPROVED	CHECKED	DESIGNED	DRAWN	DRAWING NO.	PART NO.	CODE NO.
HS. OKAWA	KI. HIROKAWA	TH. SANO	TH. SANO	EDC3-334389-00	FX18-120S-0.8SV15	CL579-0029-1-00

Aug.1.2016 Copyright 2016 HIROSE ELECTRIC CO., LTD. All Rights Reserved.

RECOMMENDED LAND PATTERN DIMENSION OF PCB(2:1)
(PCB THICKNESS:t=1.6mm METAL MASK THICKNESS:t=0.12mm)

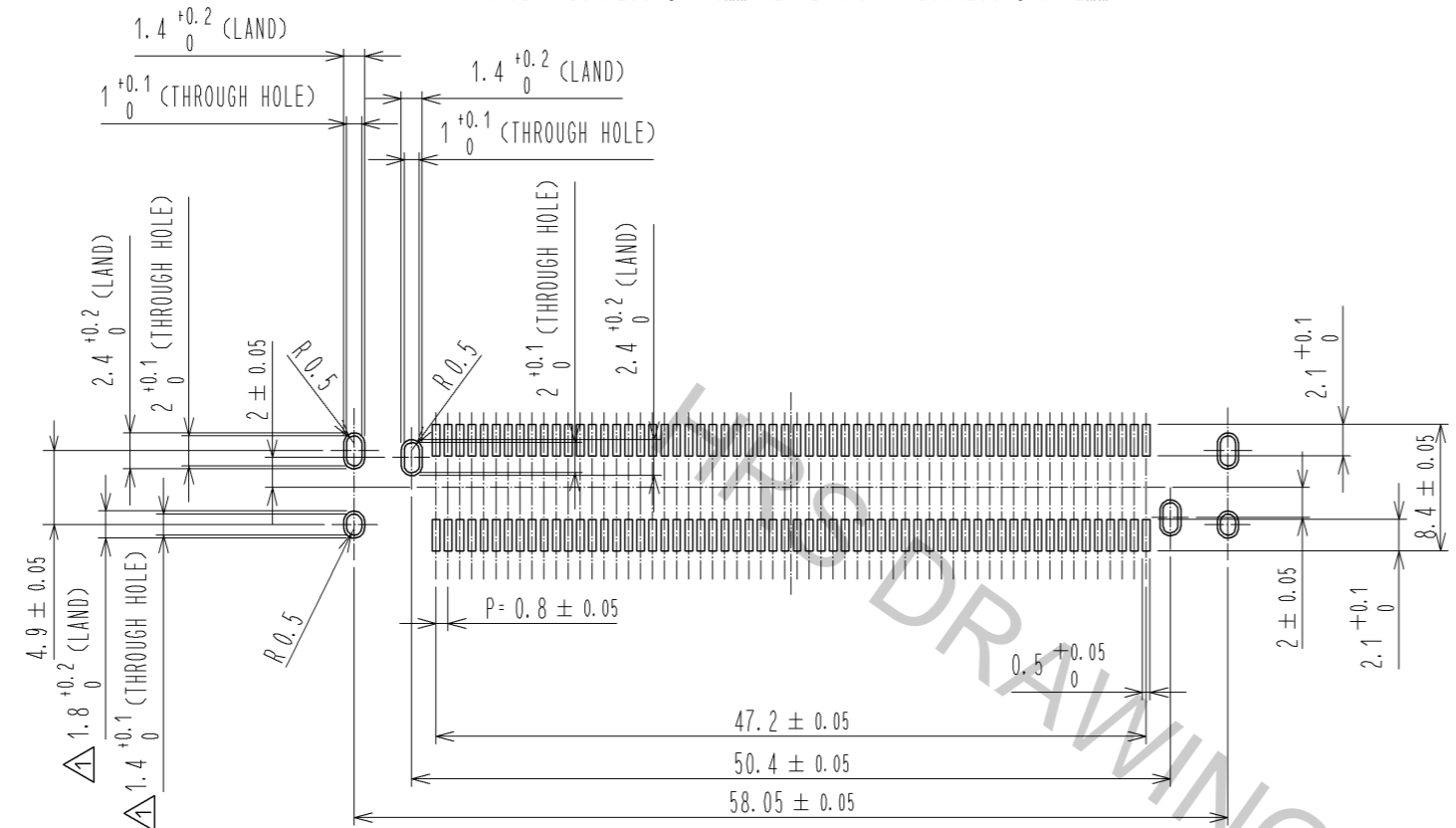

5 DRAWING FOR PACKING(1:2)

8 CONFIGURATION OF MF CONTACT A

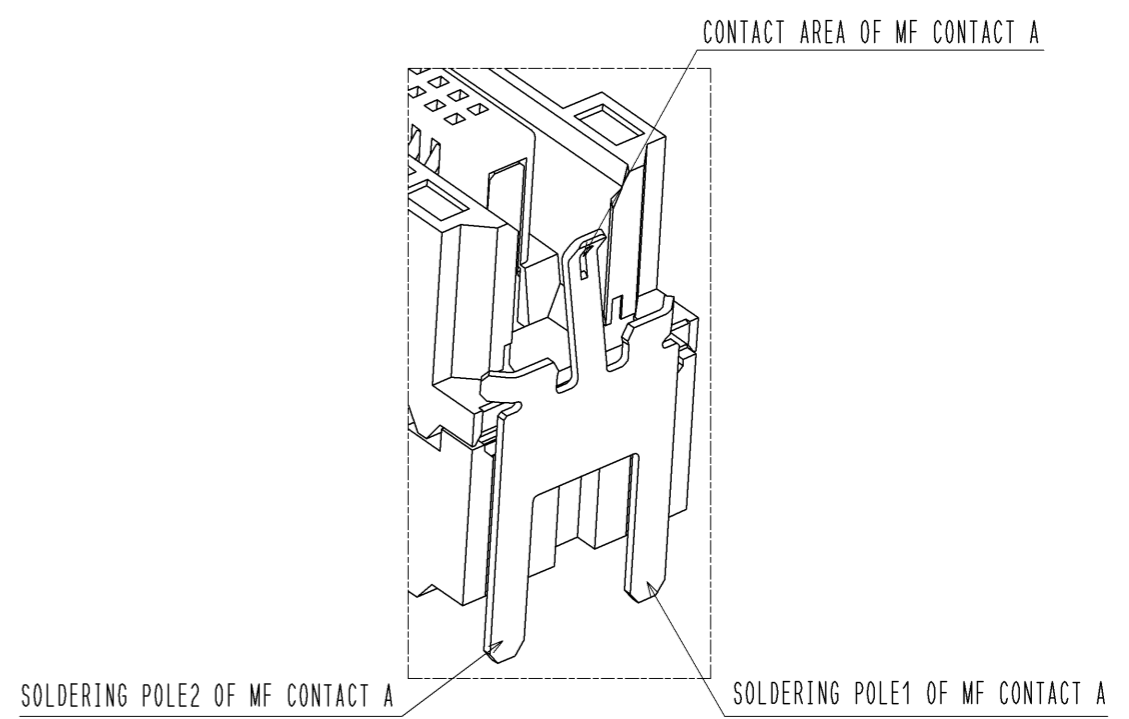

NOTE 8 SOLDERING LEAD OF MF CONTACT A SPLITS INTO TWO POLES.
BE SURE TO CONNECT TO THE SAME CIRCUIT.

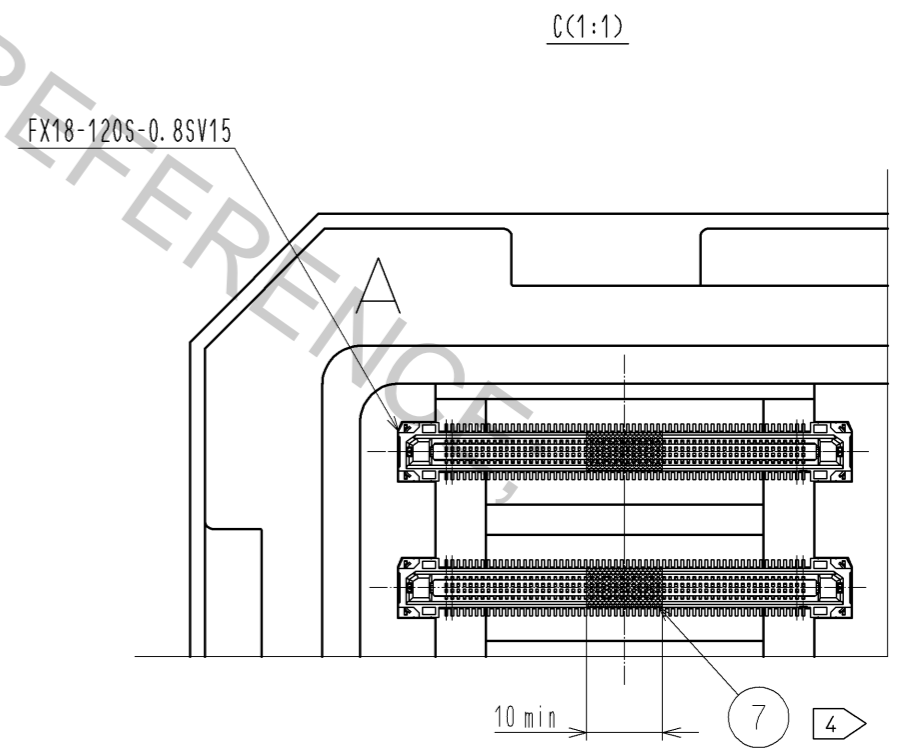
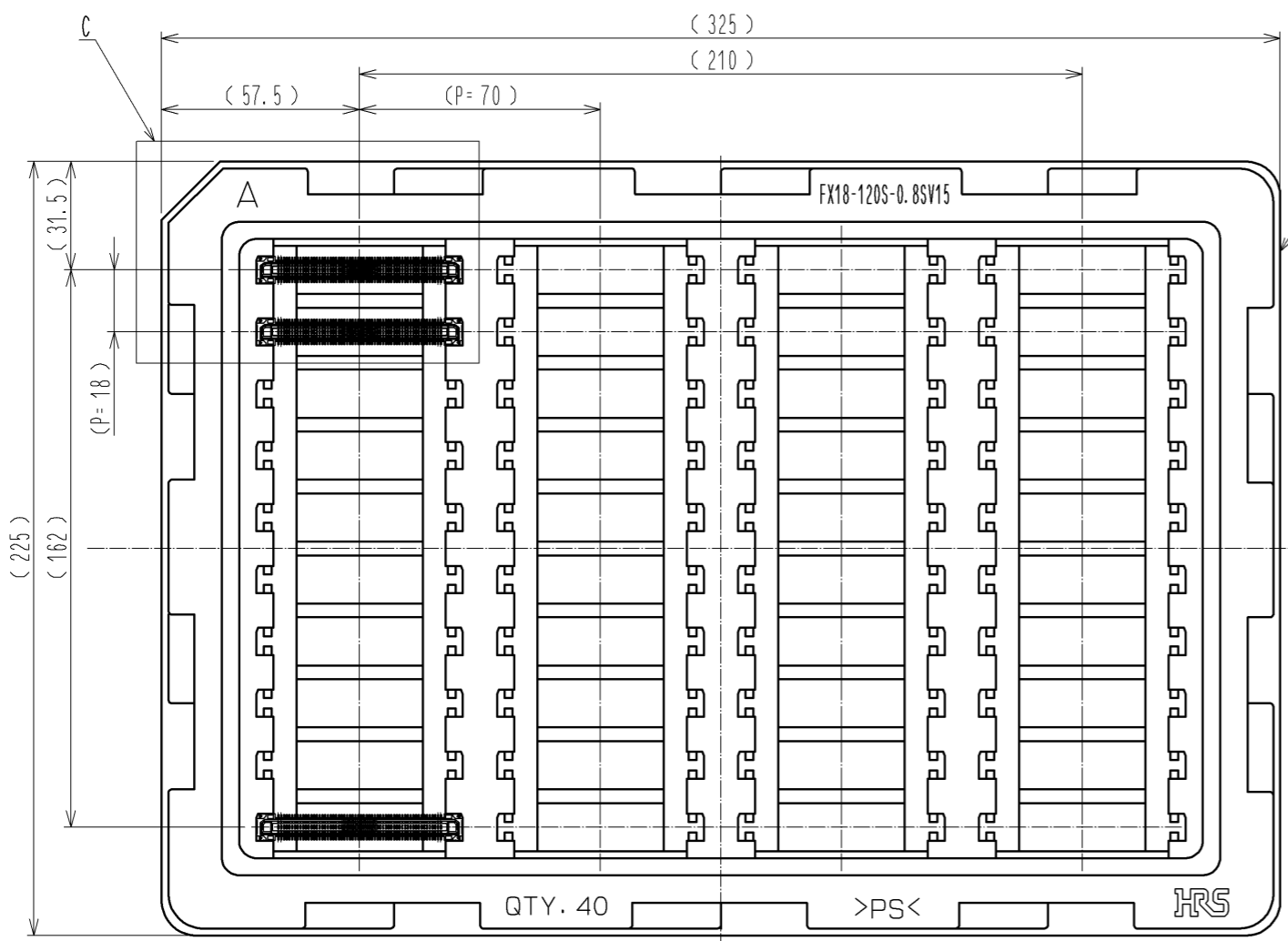

HRS	DRAWING NO.	EDC3-334389-00
	PART NO.	FX18-120S-0.8SV15
	CODE NO.	CL579-0029-1-00
		1/2