

Aug.1.2016 Copyright 2016 HIROSE ELECTRIC CO., LTD. All Rights Reserved.

COUNT	DESCRIPTION OF REVISIONS	BY	CHKD	DATE	COUNT	DESCRIPTION OF REVISIONS	BY	CHKD	DATE
1	RE-F-4613	S.M	M.T	'96.4.2					

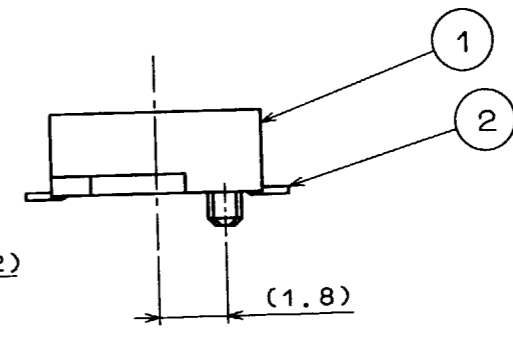
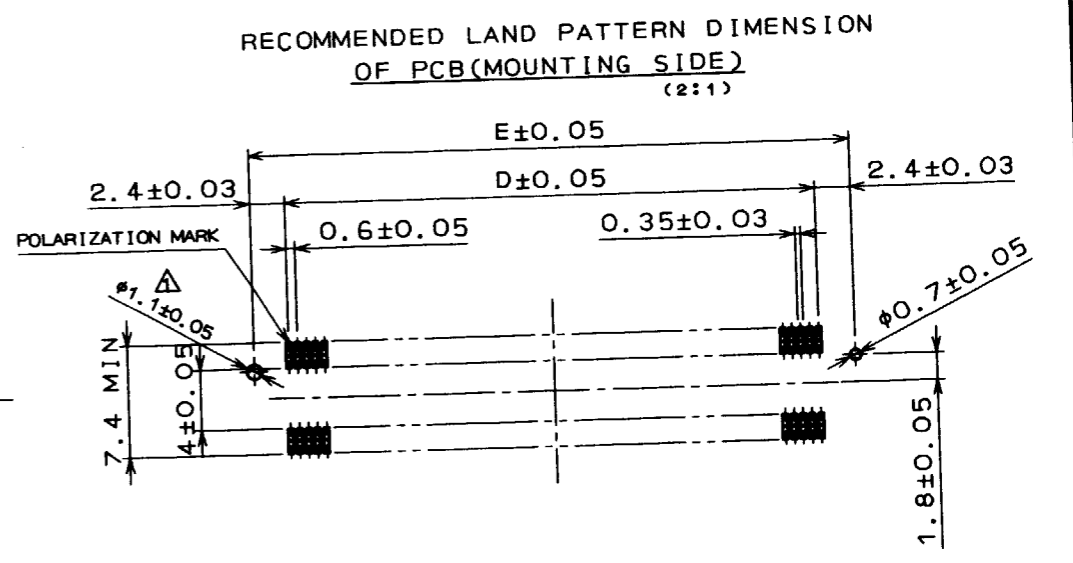
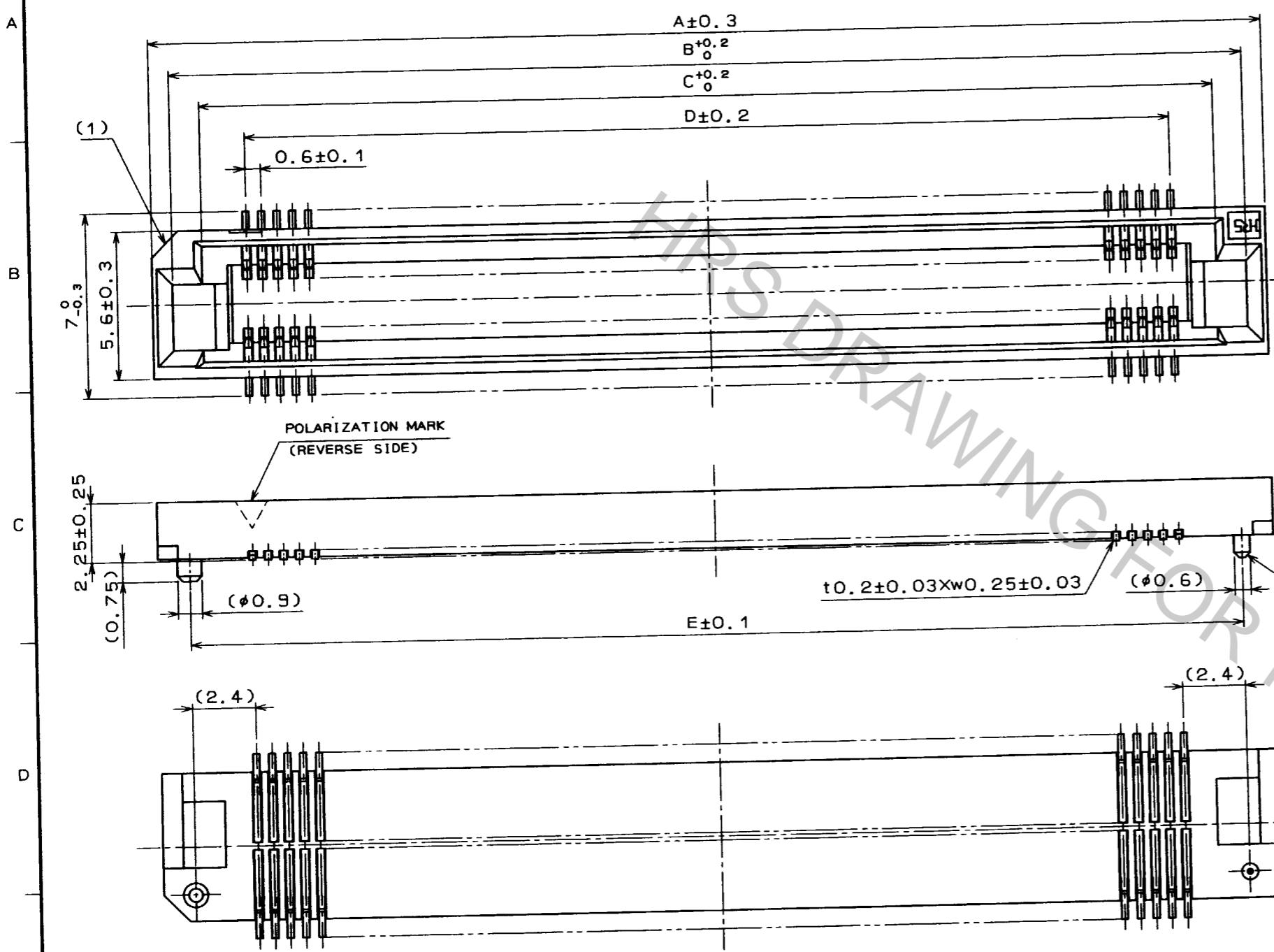

NUMBER OF CONTACT	PART NO.	CODE NO.	DRAWING NO.	A	B	C	D	E
60	FX8-60S-SV	CL578-0201-5	ADC3-150674	24.6	23.05	20.8	17.4	22.2
80	FX8-80S-SV	CL578-0203-0	ADC3-150740	30.6	29.05	26.8	23.4	28.2
90	FX8-90S-SV	CL578-0204-3	ADC3-150675	33.6	32.05	29.8	26.4	31.2
100	FX8-100S-SV	CL578-0205-6	ADC3-150676	36.6	35.05	32.8	29.4	34.2
120	FX8-120S-SV	CL578-0206-9	ADC3-150677	42.6	41.05	38.8	35.4	40.2
140	FX8-140S-SV	CL578-0207-1	ADC3-150678	48.6	47.05	44.8	41.4	46.2

NOTE 1 READ CO-PLANARITY SHALL BE 0.1mm.
 2 FOR MODIFICATION, ETC., PREVENTIVE HOLE FOR SINK MARK MAY BE ADDED DEPENDS ON CIRCUMSTANCES.

2	PHOSPHOR BRONZE	CONTACT AREA: GOLD (0.1μm) OVER NICKEL OTHERS: GOLD (FLASH) OVER NICKEL	1	PPS	LIGHT BROWN (UL94V-0)
NO.	MATERIAL	FINISH, REMARKS	NO.	MATERIAL	FINISH, REMARKS
CODE NO. (OLD)		DRAWN	DESIGNED	CHECKED	APPROVED
		S. Morita	J. Matsukawa	M. Tomita	Y. Yoshimura
		950420	950420	950420	950420
DRAWING NO. EDC3-150730			PART NO. FX8-***S-SV		
SCALE 5:1			CODE NO. CL578		
UNITS mm			HRS HIROSE ELECTRIC CO., LTD.		

TO
PCM