

1		2			3			4		
COUNT	DESCRIPTION OF REVISIONS	BY	CHKD	DATE	COUNT	DESCRIPTION OF REVISIONS	BY	CHKD	DATE	
1	DIS-C-000409	D.M	M.S	06.12.19						

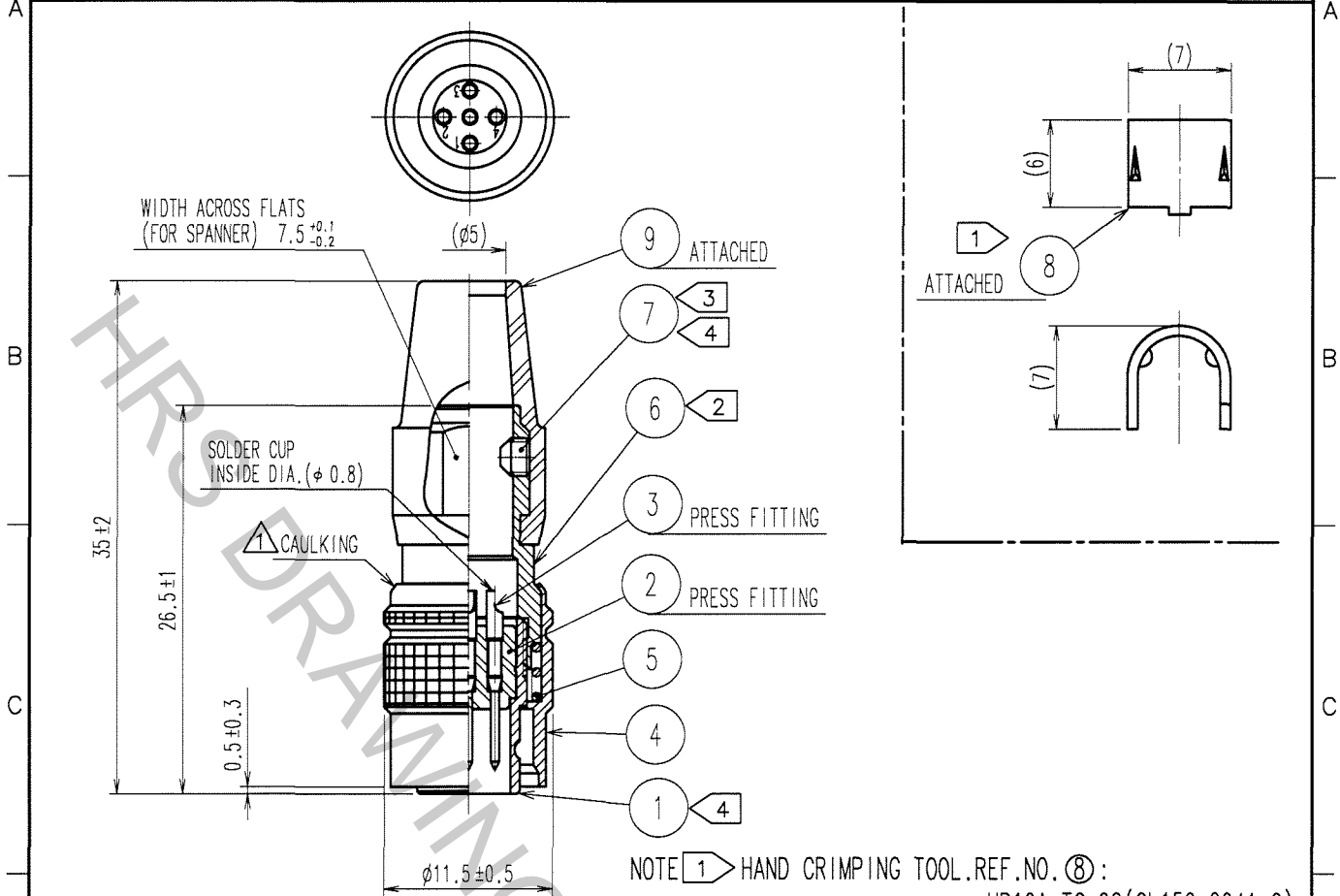

- NOTE ① HAND CRIMPING TOOL. REF. NO. ⑧ :
HR10A-TC-02 (CL150-0041-2)
- ② THE HOLE DIAMETER FOR CRIMPING: $\phi 5.3$
- ③ THE RECOMMENDED CLAMP TORQUE, REF. NO. ⑥ : 1.5-2 N·m.
- ④ ACROSS FLATS HEXAGON HEAD OF REF. NO. ⑦ : 1.27
- ⑤ THE RECOMMENDED CLAMP TORQUE, REF. NO. ⑦ : 0.3-0.4 N·m.
- ⑥ LOCTITE 242, HENKEL JAPAN OR EQUIVALENT IS RECOMMENDED TO PREVENT REF. NO. ① AND ⑦ FROM LOOSENING.
- ⑦ ONE EXAMPLE OF THE ROTATION OF REF. NO. ⑥ TO REF. NO. ① IS SHOWN.

5	STEEL	NICKEL PLATING			
4	BRASS	MATTE FINISH NICKEL PLATED	9	CR	(BLACK)
3	BRASS	SILVER PLATING 2 μ m min.	8	BRASS	
2	POLYAMIDE	(BLACK) UL94V-0	7	STEEL	NICKEL PLATING HEXAGON SOCKET SET SCREW M2.6x0.45x2
1	ZINC ALLOY	MATTE FINISH NICKEL PLATED	6	BRASS	NICKEL PLATING
NO.	MATERIAL	FINISH, REMARKS	NO.	MATERIAL	FINISH, REMARKS

CODE NO. (OLD) CL		DRAWN T. KOMATSU 05.11.16	DESIGNED D. MATSUNE 05.11.18	CHECKED E. KUNII 05.11.22	APPROVED M. SATO 05.11.25	RELEASED
DRAWING NO. EDC4-025301-73		PART NO. HR10A-7P-5P(73)				
SACLE 2 : 1		CODE NO. CL110-0318-5-73				1 1
UNITS mm		HRS HIROSE ELECTRIC CO., LTD.				

TO
R