

COUNT	DESCRIPTION OF REVISIONS	BY	CHKD	DATE	COUNT	DESCRIPTION OF REVISIONS	BY	CHKD	DATE
1	DIS-C-000585	T.K	E.K	07.07.27					

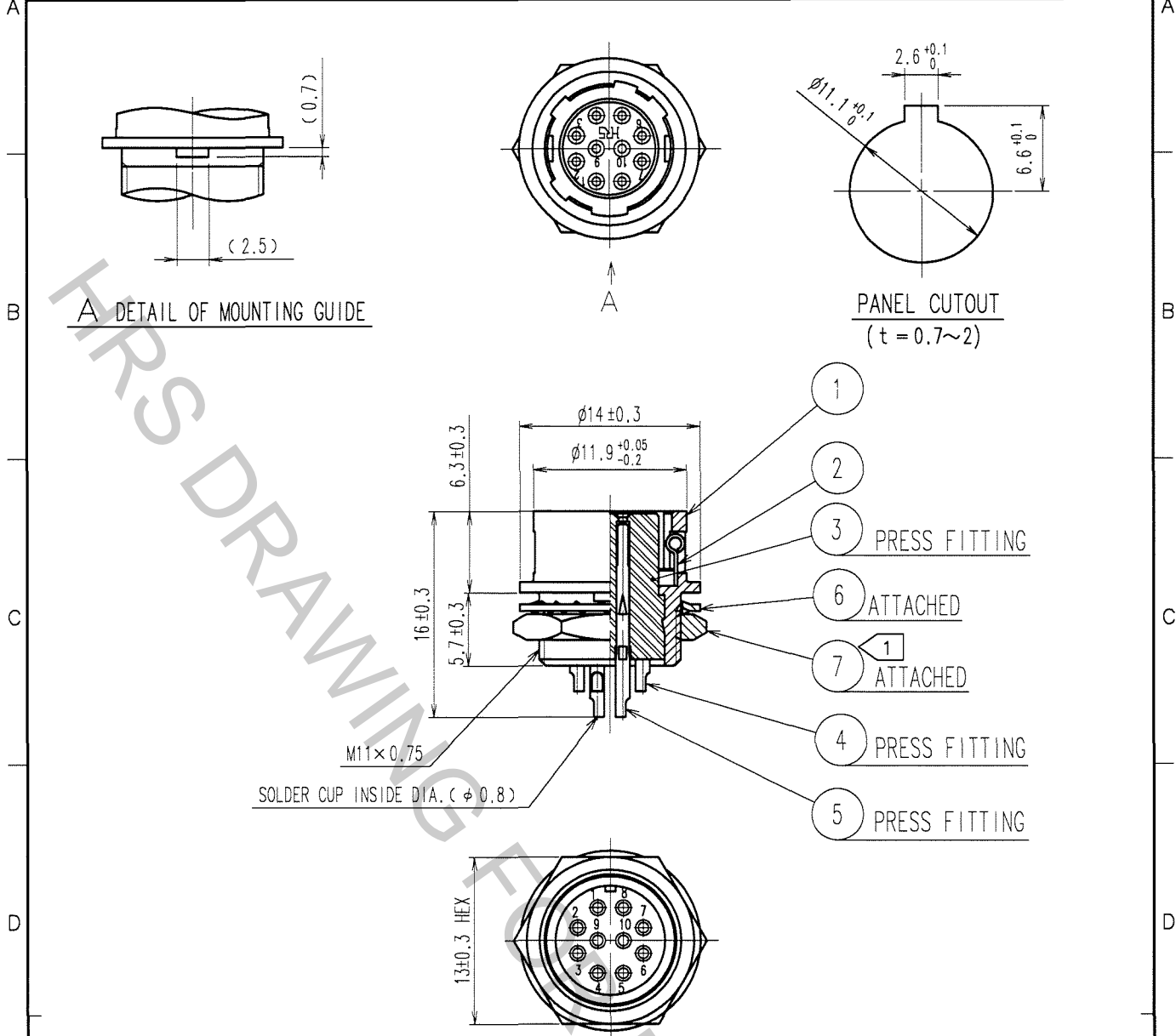

NOTE 1 THE RECOMMENDED CLAMP TORQUE OF REF. NO. 7 TO BE 2 N · m.
 LOCTITE 242, HENKEL JAPAN OR EQUIVALENT IS RECOMMENDED TO
 PREVENT REF. NO. 7 FROM LOOSENING.

3	POLYAMIDE	(BLACK) UL94V-0	7	BRASS	NICKEL PLATING
2	STAINLESS STEEL		6	PHOSPHOR BRONZE	NICKEL PLATING
1	ZINC ALLOY	MATTE FINISH NICKEL PLATED	5	PHOSPHOR BRONZE	SILVER PLATING 2μm min.
			4	PHOSPHOR BRONZE	
NO.	MATERIAL	FINISH, REMARKS	NO.	MATERIAL	FINISH, REMARKS

CODE NO. (OLD)	DRAWN	DESIGNED	CHECKED	APPROVED	RELEASED
CL	D.MATSUNE	D.MATSUNE	E.KUNII	M.SATO	
	'05 10 01	'05 10 01	'05 10 03	'05 10 14	

TO
R

 SCALE 2 : 1 UNITS mm	DRAWING NO. EDC4-021368-71 HIROSE ELECTRIC CO., LTD.	PART NO. HR10A-10R-10S(71) CODE NO. CL110-0409-9-71	1 1
-----------------------------------	--	--	--------