

Aug.1.2016 Copyright 2016 HIROSE ELECTRIC CO., LTD. All Rights Reserved.

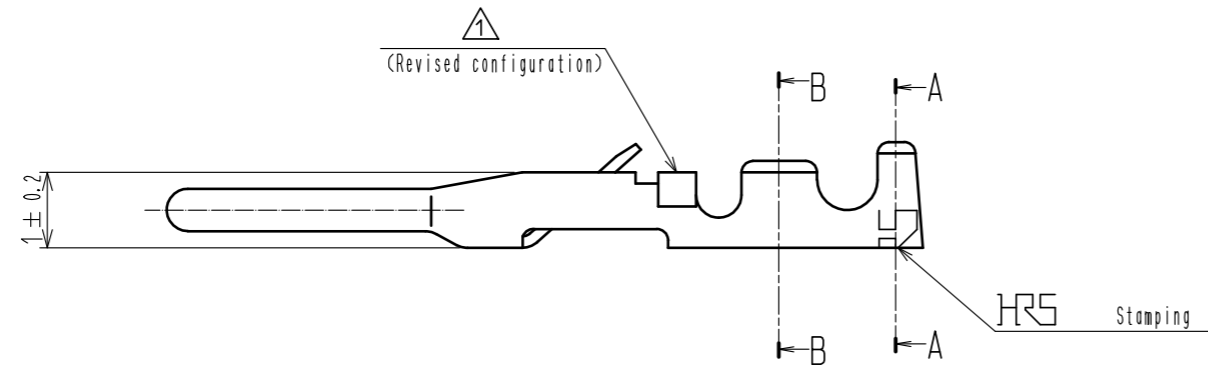
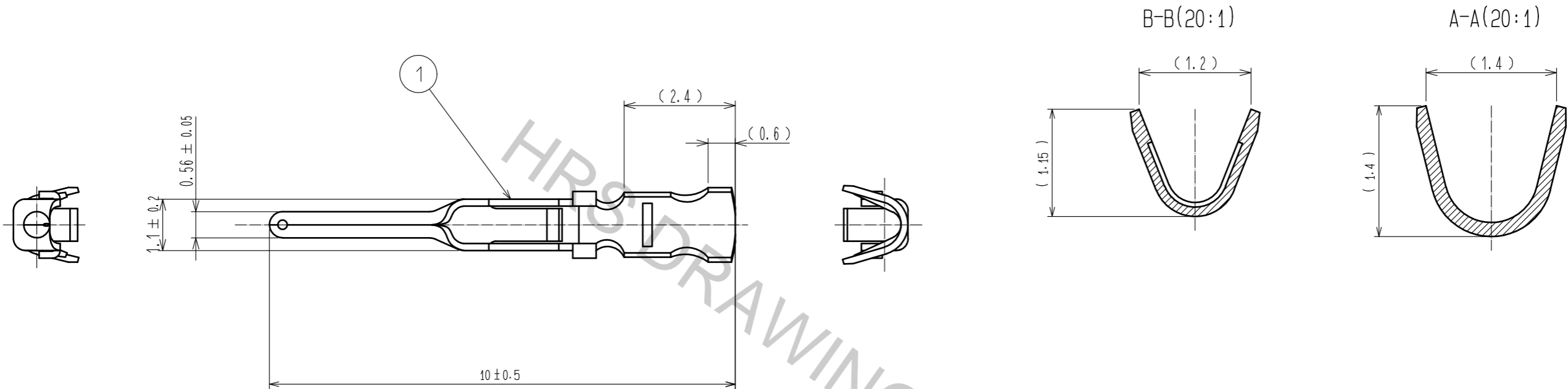

Notes 1 Applicable wire : AGW #26~#30
 △ Hand crimping tool : HT802/HR12-SC-1(CL150-0400-3-00)

1	Phosphor bronze	Silver plated (100bulk contacts are contained per bag.)
NO.	MATERIAL	FINISH . REMARKS
UNITS mm		SCALE 10:1
		COUNT 1
		DESCRIPTION OF REVISIONS DIS-C-00000816
		DESIGNED HK. NAMAI
		CHECKED HY. KOBAYASHI
		DATE 16. 02. 23
HRS	HIROSE ELECTRIC CO., LTD.	APPROVED : MR. YOSHIDA 05. 01. 05
		CHECKED : MO. SATOH 05. 01. 05
		DESIGNED : YH. YAMADA 05. 01. 05
		DRAWN : YH. YAMADA 05. 01. 05
		DRAWING NO. EDC3-021603-00
		PART NO. HR10-PC-112
		CODE NO. CL110-0513-0-00