

Aug.1.2016 Copyright 2016 HIROSE ELECTRIC CO., LTD. All Rights Reserved.

COUNT	DESCRIPTION OF REVISIONS	BY	CHKD	DATE	COUNT	DESCRIPTION OF REVISIONS	BY	CHKD	DATE
2	DIS-C-000633	H.Z	K.E	07.05.28					

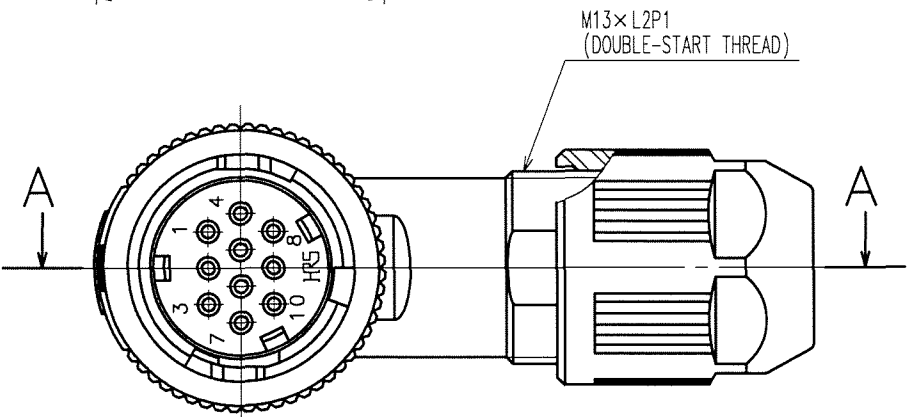
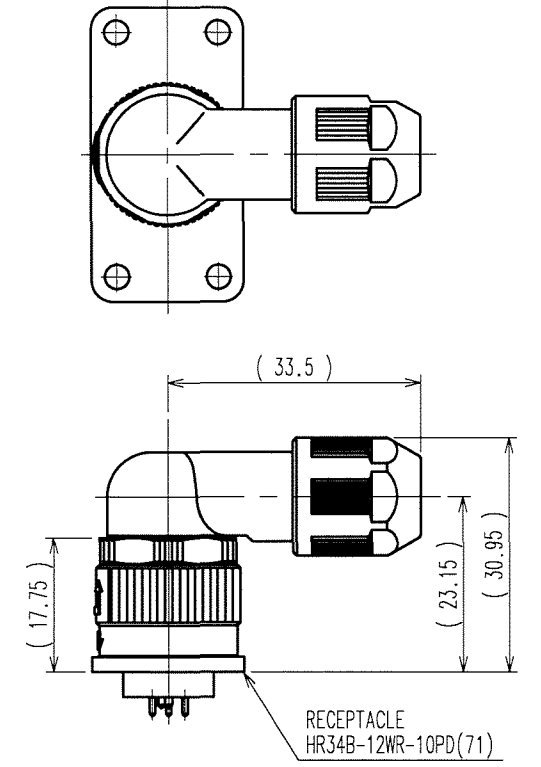
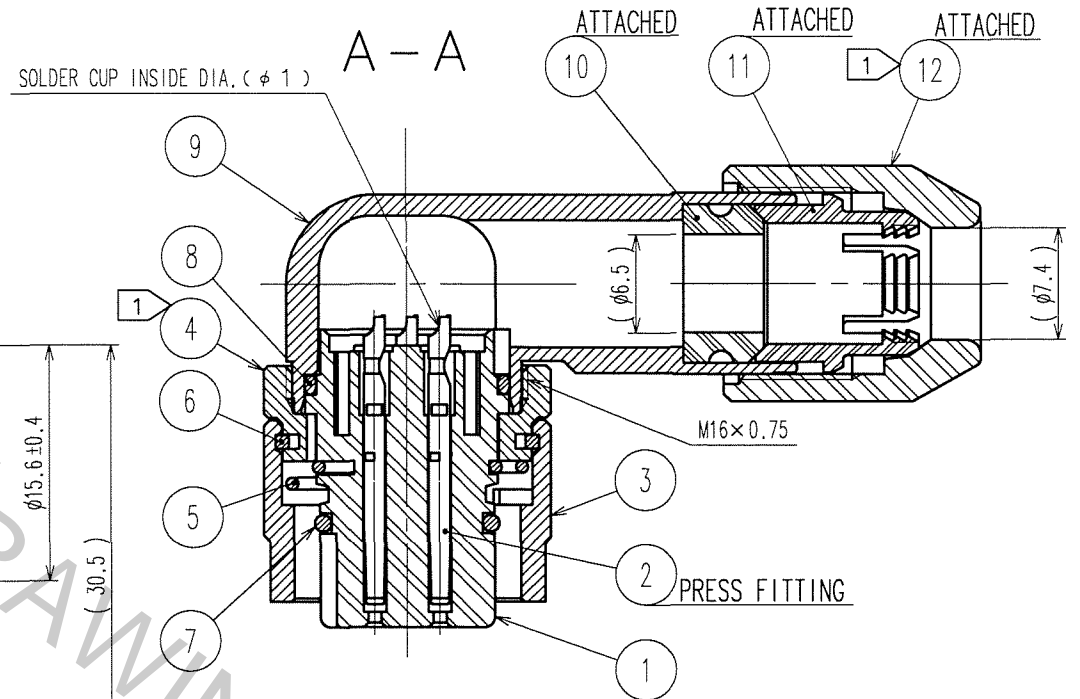
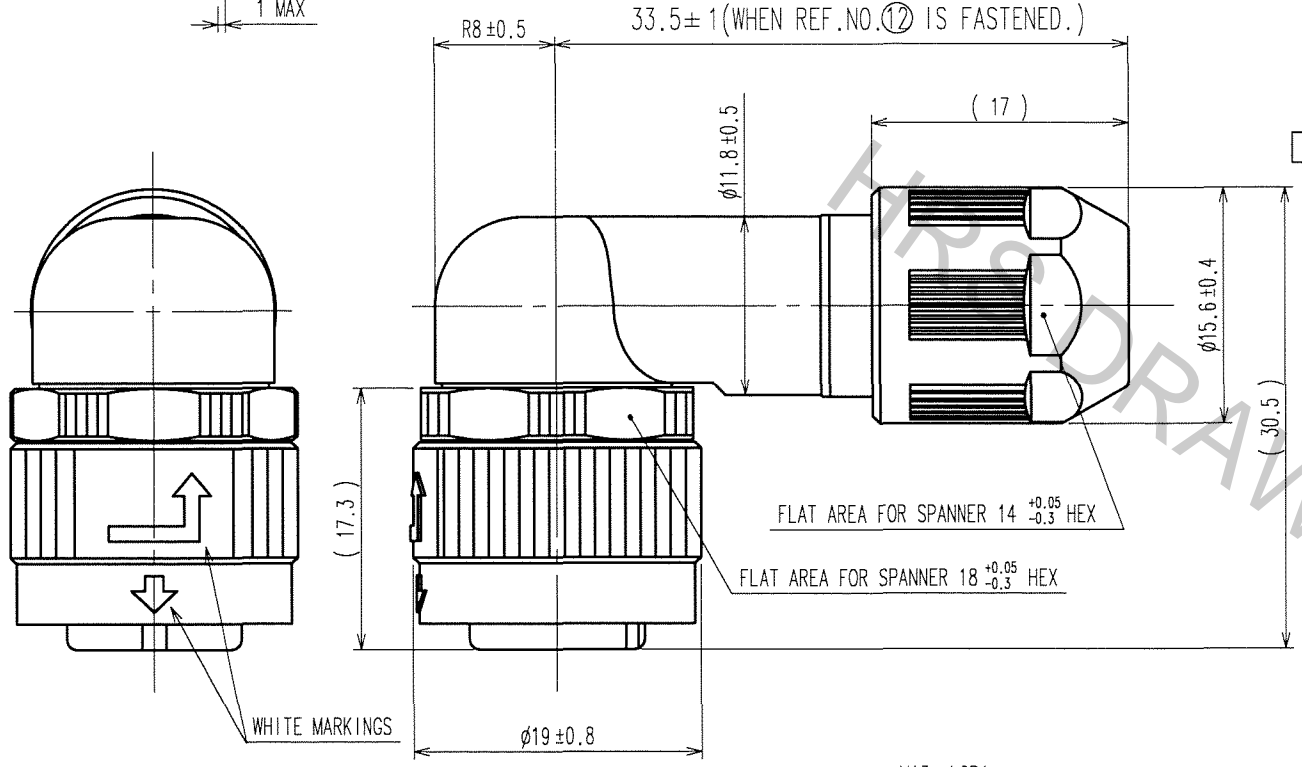
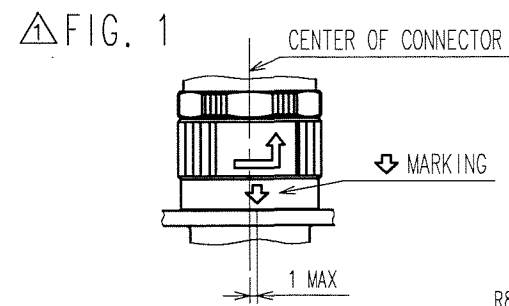

5	STAINLESS STEEL		12	POLYPHENYLENE SULFIDE (BLACK)	UL94V-0
4	ZINC ALLOY	BLACK CHROME PLATING	11	POLYAMIDE (WHITE)	UL94V-0
3	ZINC ALLOY	BLACK CHROME PLATING	10	HYDROGENATION ACRYLONITRILE BUTADIENE RUBBER (BLACK)	
2	PHOSPHOR BRONZE	CONTACT AREA :GOLD 0.2μ m MIN. TERMINAL AREA:GOLD FLASH. UNDER PLATING:NICKEL 2μ m MIN.	9	ALUMINIUM ALLOY	BLACK CHROMATE TREATMENT (TRIVALENT CHROMIUM)
1	POLYPHENYLENE SULFIDE (BLACK)	UL94V-0	8	FLURO RUBBER (BLACK)	
			7	FLURO RUBBER (BLACK)	
			6	PHOSPHOR BRONZE	NICKEL PLATING
NO.	MATERIAL	FINISH, REMARKS	NO.	MATERIAL	FINISH, REMARKS

NOTES 1 THE RECOMMENDED TIGHTENING TORQUE, ADHESIVE AND PRIMER FOR M16×0.75 PORTION OF REF NO. ④ AND ⑨ AND M13×L2P1 PORTION OF REF NO. ⑨ AND ⑫ ARE AS FOLLOWINGS.  
 THE ADHESIVE AND PRIMER SHOULD BE ATTACHED ON THE MALE SCREW PORTION OF REF NO. ⑨ .  
 TIGHTENING TORQUE: 0.9 TO 1 N·m.  
 ADHESIVE: LOCTITE 242 MADE BY HENKEL JAPAN LTD.  
 PRIMER: LOCK PRIMER 7649, MADE BY HENKEL JAPAN LTD. (ONLY M13×L2P1)

- 2 ROTATION EXAMPLES ARE SHOWN FOR REF.NO. ①, ④, ⑨, AND ⑫.
- 3 THE RECOMMENDED CABLE:UL20276-SB(FLEX)5×23AWG+1P×25AWG MADE BY HITACHI CABLE LTD.
- 4 CONDUIT IS NOT APPLICABLE TO THIS CONNECTOR.
- 5 MAKE SURE THAT ↕ MARKING IS POSITIONED WITHIN 1 FROM THE CENTER OF CONNECTOR AS SHOWN IN FIG.1.WHEN MATED TO THE APPLICABLE RECEPTACLE,OTHERWISE, THE CONNECTORS ARE NOT COMPLETELY MATED,AND INSERT THIS PLUG TO THE RECEPTACLE TO THE END UNTIL THE ↕ MARKING IS LOCATED IN THE CENTER OF THE CONNECTOR.

CODE NO. (OLD)		DRAWN	DESIGNED	CHECKED	APPROVED	RELEASED
CL		M. SATO	H. ZENBA	K. EZAWA	M. SATO	
		07.04.03	07.04.03	07.04.03	07.04.03	
DRAWING NO.		PART NO.				
EDC3-114025-71		HR34B-12WLPA-10S(71)				
SCALE		CODE NO.				
2 : 1		CL134-0005-0-71				
UNITS		mm				

TO
R