

Aug.1.2016 Copyright 2016 HIROSE ELECTRIC CO., LTD. All Rights Reserved.

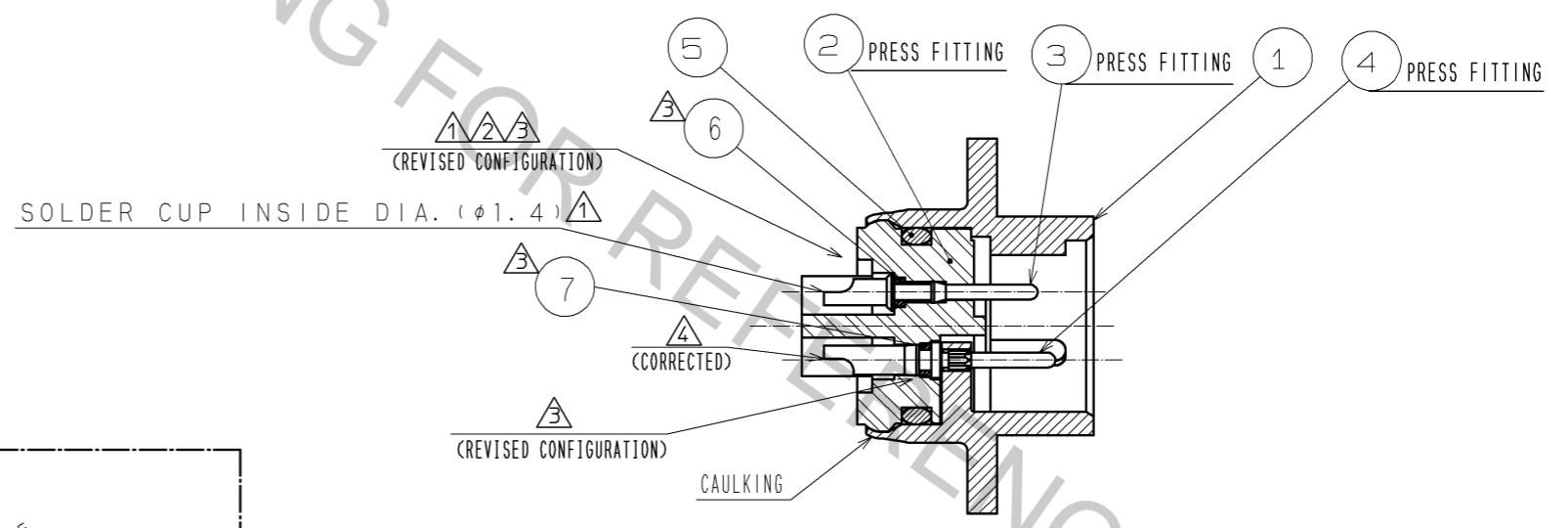

NOTES 1 CHECK THAT THE O-RING IS PROPERLY SET AT THE GROOVE OF THE DEVICE.
WHILE MOUNTING THE CONNECTOR, MAKE SURE THAT THE O-RING IS NOT CAUGHT.

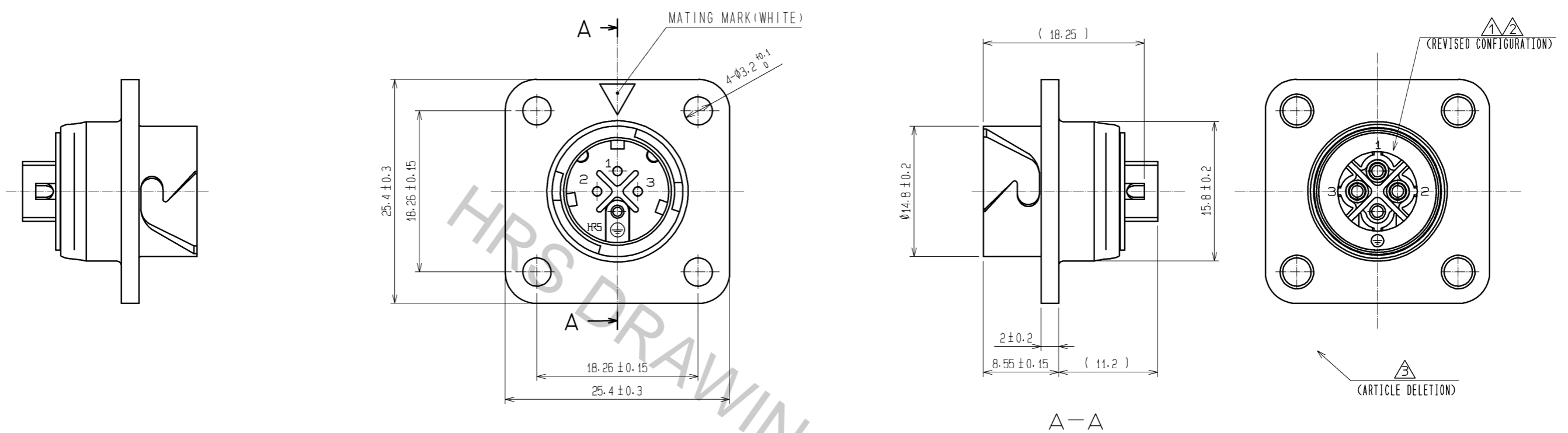
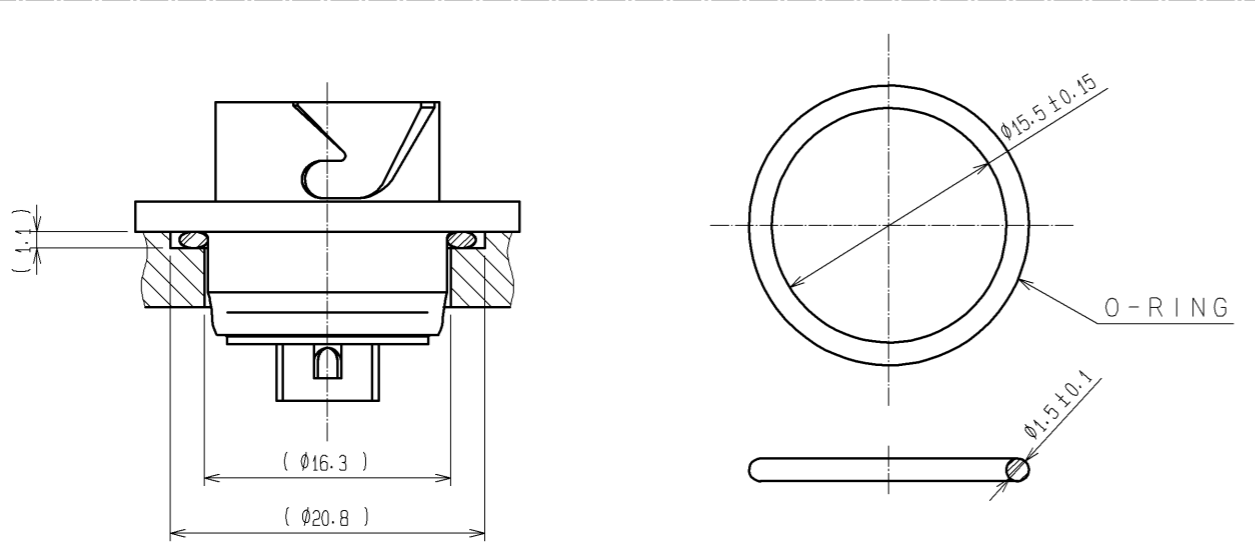

PANEL CUTOUT AND O-RING (REFERENCE)

NO.	MATERIAL	FINISH	REMARKS	NO.	MATERIAL	FINISH	REMARKS
4	BRASS	SILVER PLATING 2μm MIN					
3	BRASS	SILVER PLATING 2μm MIN	△7		FLUORO RUBBER (BLACK)		
2	POLYPHENYLENE SULFIDE	(BLACK) UL94V-0	△6		FLUORO RUBBER (BLACK)		
1	ZINC ALLOY	BLACK CHROMATE TREATMENT (Cr3)		5	FLUORO RUBBER (BLACK)		

UNITS	SCALE	COUNT	DESCRIPTION OF REVISIONS	DESIGNED	CHECKED	DATE
mm	2:1	1	DIS-C-001248	HT. ZENBA	SI. MATSUZAKI	09.04.23

APPROVED	DATE	DRAWING NO.
MO. SATOH	07.10.17	EDC3-114851-00
CHECED	DATE	PART NO.
EJ. KUNII	07.10.17	HR34B-12WRB-4P
DESIGNED	DATE	CODE NO.
DS. MATSUNE	07.10.16	CL134-0021-6-00
DRAWN	DATE	
HN. TANAKA	07.10.10	