

Aug.1.2016 Copyright 2016 HIROSE ELECTRIC CO., LTD. All Rights Reserved.

COUNT	DESCRIPTION OF REVISIONS	BY	CHKD	DATE	COUNT	DESCRIPTION OF REVISIONS	BY	CHKD	DATE
2	DIS-E-001346	Y.S	Y.E	07.03.16					

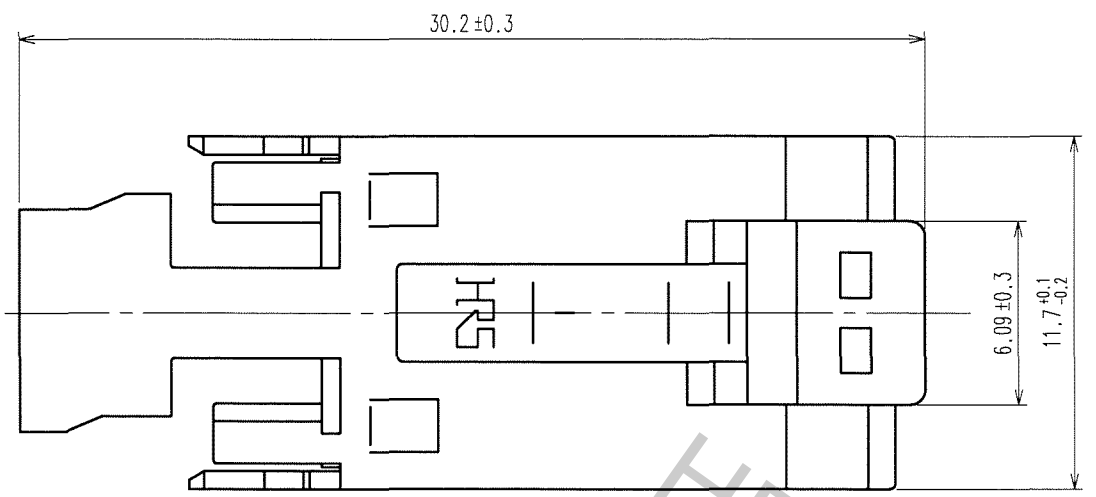

NOTES. 1. APPLICABLE CABLE.

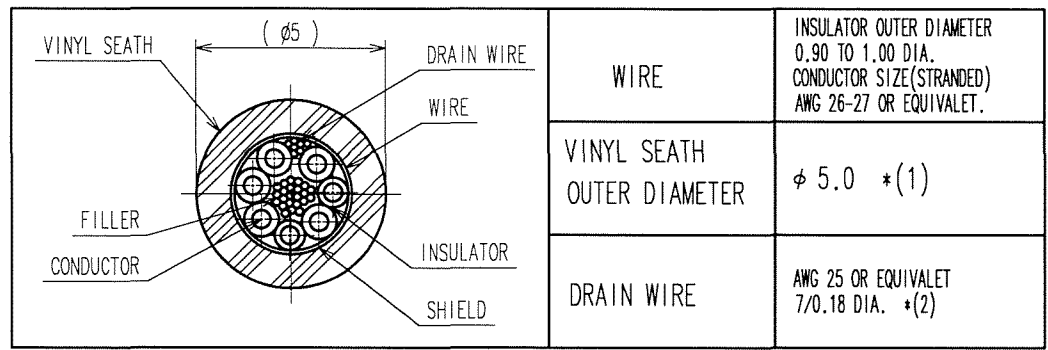

- *(1) CABLE ENTRY IS 5.6 MIN.
- *(2) CONSTRUCTION IS FOR REFERENCE.

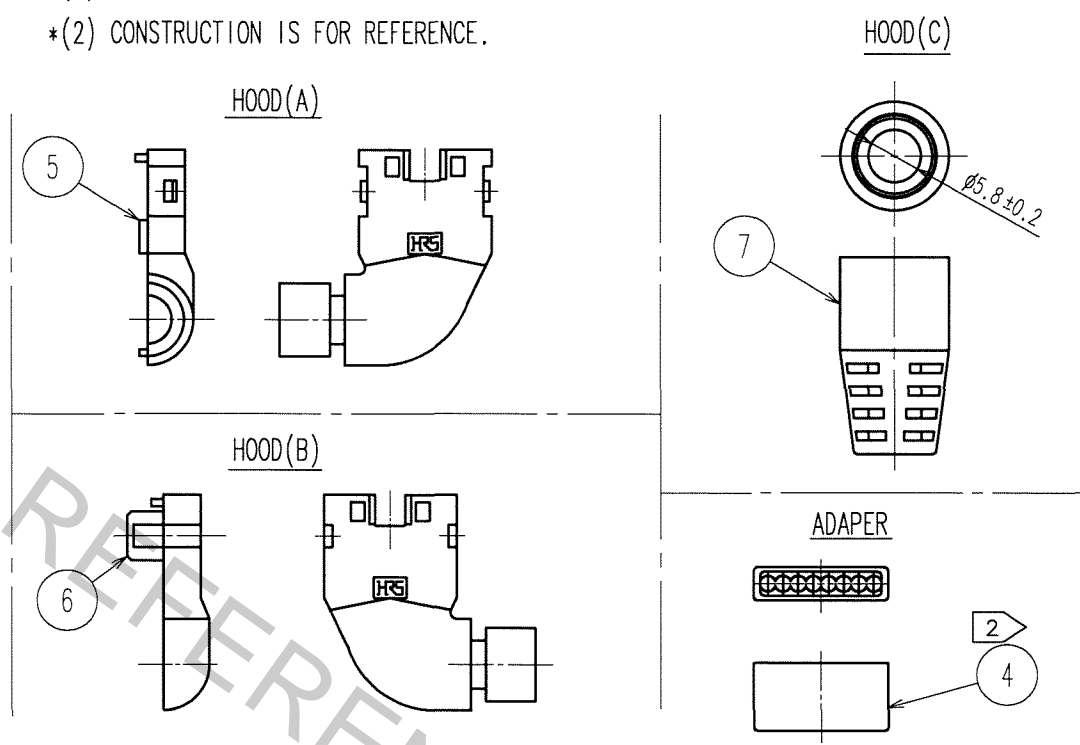
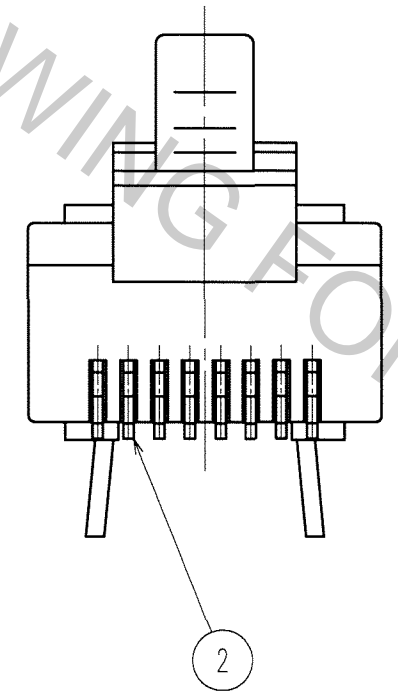
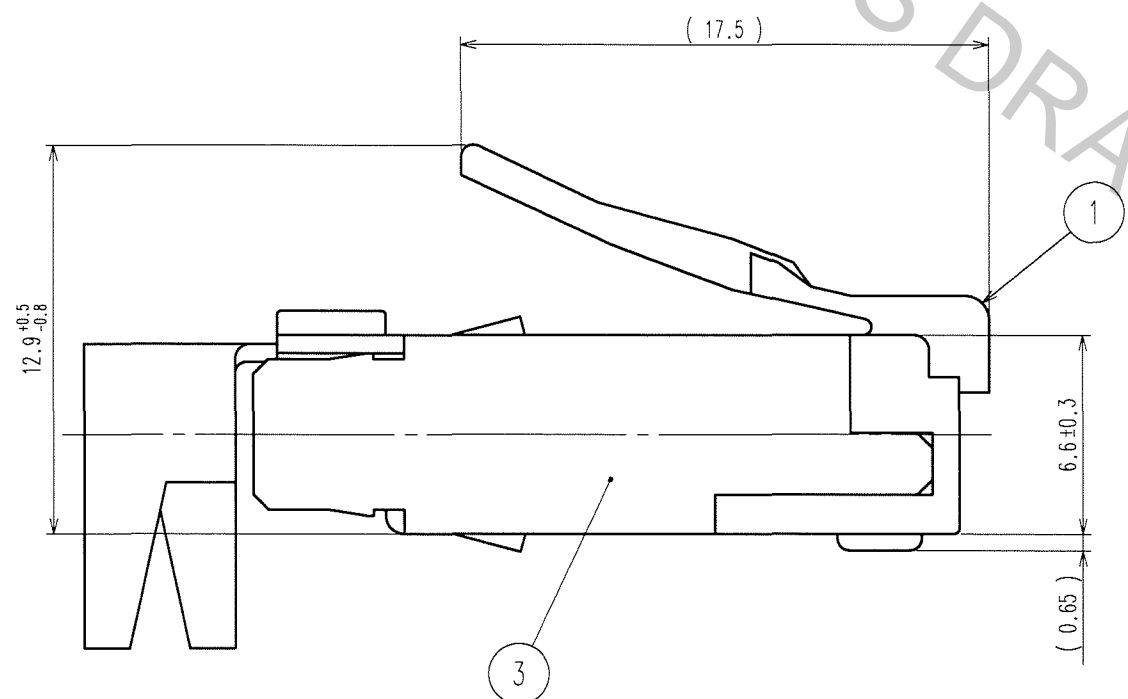

- 2 ADAPTER SHALL BE USED TO ALIGN INDIVIDUAL WIRE.
- 3. THE DIMENSION IN PARENTHESIS IS FOR REFERENCE.

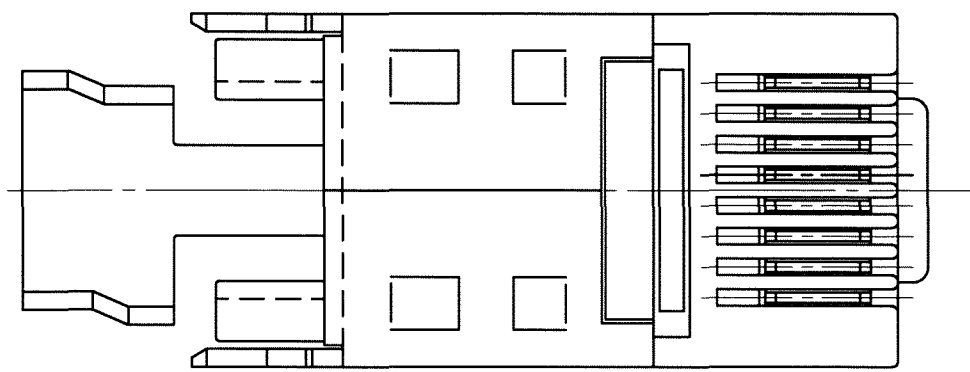

3	BRASS	OVER: TIN REFLOW PLATING 1μ m min UNDER: COPPER PLATING 0.5μ m min	7	PVC	BLACK
2	PHOSPHOR BRONZE	CONTACT: GOLD PLATING 1.27μ m min TERMINAL: GOLD PLATING 0.03μ m min UNDER: NICKEL PLATING 2μ m min	6	POLYCARBONATE	BLACK
1	POLYCARBONATE	TRANSPARENCY	5	POLYCARBONATE	BLACK
			4	POLYCARBONATE	TRANSPARENCY
NO.	MATERIAL	FINISH, REMARKS	NO.	MATERIAL	FINISH, REMARKS

CODE NO. (OLD)	DRAWN	DESIGNED	CHECKED	APPROVED	RELEASED
	Y.SATO	T.TANIGUCHI	Y.ENAMI	H.MIWA	
	05.09.21	05.10.03	05.10.07	05.10.13	

 SCALE 4 : 1 UNITS mm	DRAWING NO. EDC3-120680-01 HRS HIROSE ELECTRIC CO., LTD	PART NO. TM11APA-88P(03) CODE NO. CL222-2781-9-03	1/1
-----------------------------------	---	--	-----

TO
Q2