

Aug.1.2016 Copyright 2016 HIROSE ELECTRIC CO., LTD. All Rights Reserved.

RECOMMENDED PATTERN

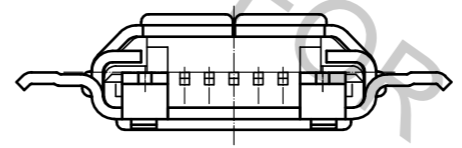

4 DRAWING FOR PACKING(FREE)

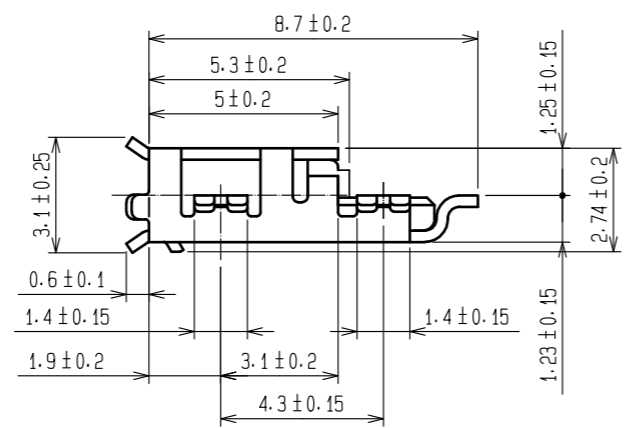
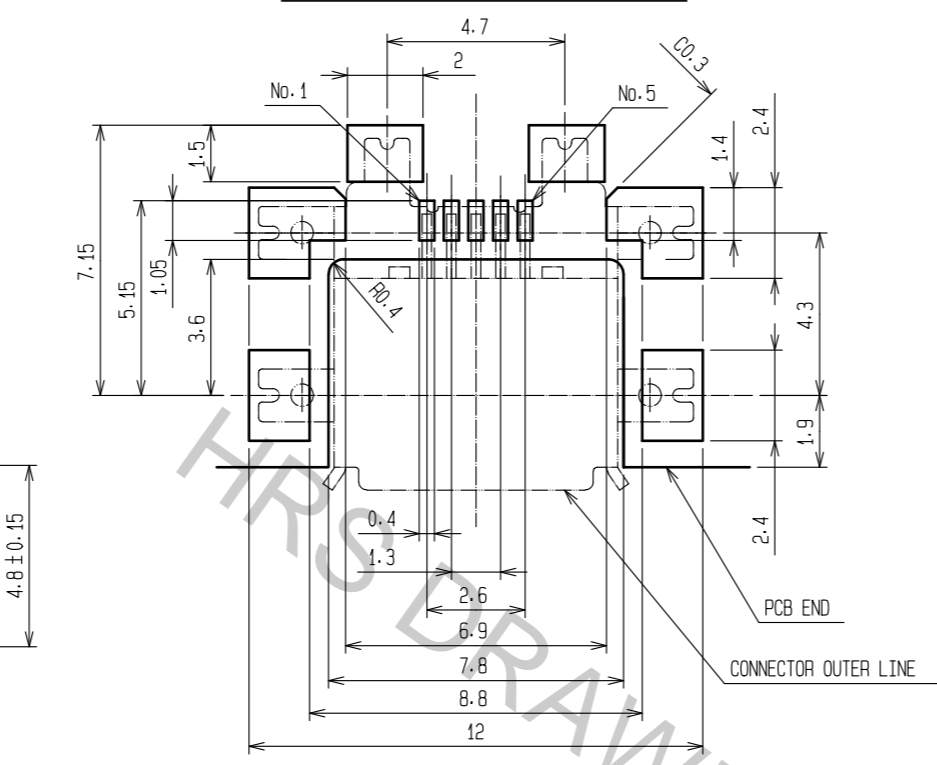
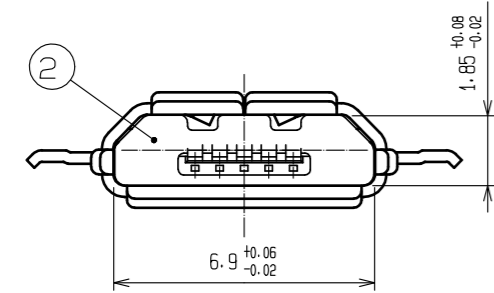
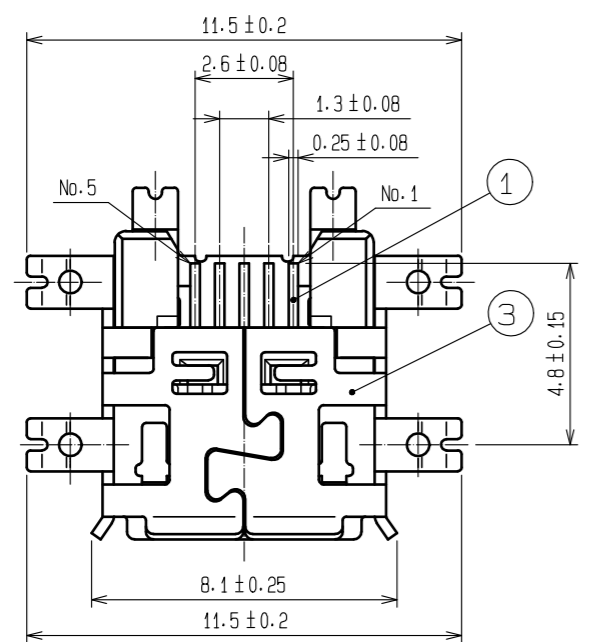
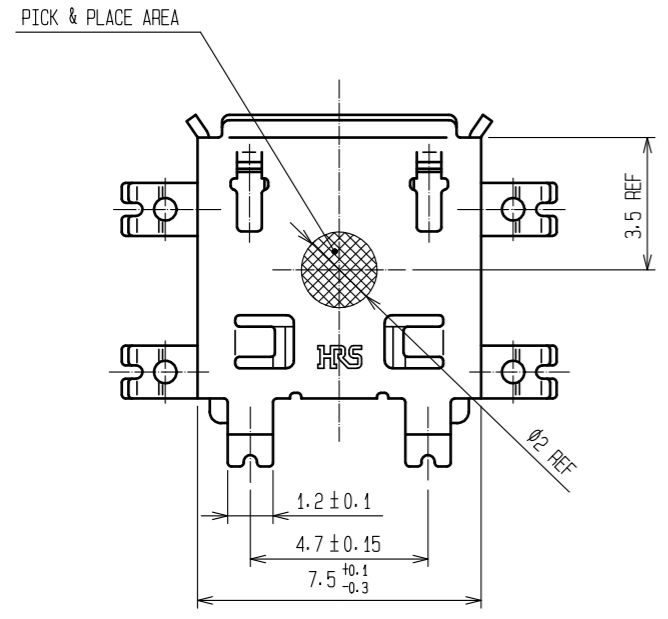
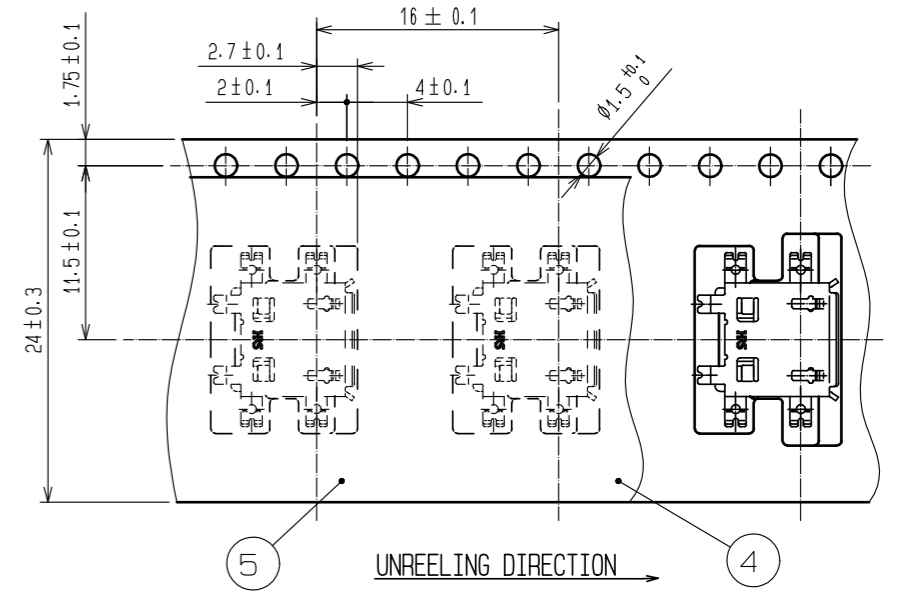

- NOTES 1 INTERFACE DIMENSIONS CONFORMS TO MICRO-B RECEPTACLE OF USB STANDARDS.  
 2 CO-PLANARITY TO BE 0.08 MAX.  
 3 PLATING  
 CONTACT AREA : GOLD 0.05μm MIN.  
 OVER PALLADIUM NICKEL 0.75μm MIN.  
 LEAD AREA : GOLD 0.05μm MIN.  
 UNDER PLATING: NICKEL 2μm MIN.  
 4 PER REEL: 1500 pcs  
 5 AS FOR PART No.3, THE PERFORMANCE REMAINS GOOD EVEN IF THERE IS A RUBBING WOUND BY THE ASSEMBLY PROCESS, AND THE PERFORMANCE REMAINS GOOD EVEN IF THERE IS A DIFFERENCE OF THE COLOR OF PLATING WITH THE MANUFACTURING LOT.

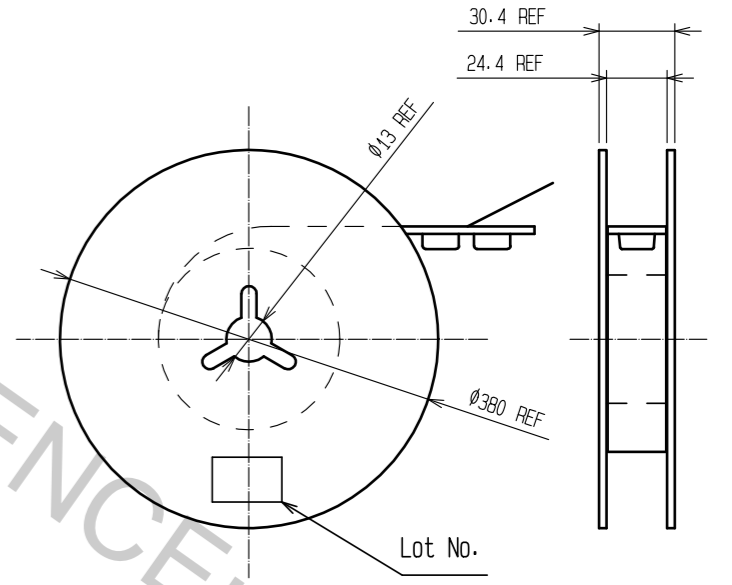

2	LCP	COLOR BLACK UL94V-0	5	PE	
1	COPPER ALLOY	3	4	PS	
			3	STAINLESS STEEL	TIN PLATING 3.8μm min. LUBRICANT
NO.	MATERIAL	FINISH . REMARKS	NO.	MATERIAL	FINISH . REMARKS
UNITS mm		SCALE 5 : 1	COUNT 	DESCRIPTION OF REVISIONS	DESIGNED
					CHECKED
					DATE
APPROVED : NM. NISHIMATSU 15.10.27			DRAWING NO. EDC-126186-30-00		
CHECKED : KN. ICHIKAWA 15.10.27			PART NO. ZX62M-B-5P(30)		
DESIGNED : TS. ITO 15.10.27			CODE NO. CL242-0024-7-30		
DRAWN : AK. AKIYAMA 15.10.27					
<b>HRS</b> HIROSE ELECTRIC CO., LTD.					