

Spezifikation für Freigabe / specification for release

Kunde / customer :
 Artikelnummer / part number : **7499151120**
 Bezeichnung : **LAN-Übertrager WE-RJ45LAN 10/100/1000 BaseT**
 description : **LAN-Transformer WE-RJ45LAN 10/100/1000 BaseT**



DATUM / DATE : 2015-01-26

A Mechanische Abmessungen / dimensions :

B Lötpad / soldering spec. :

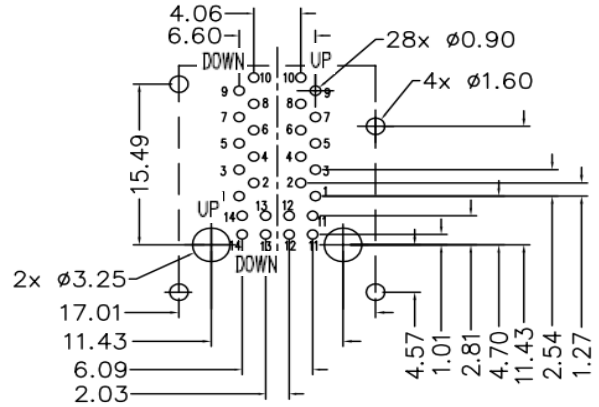
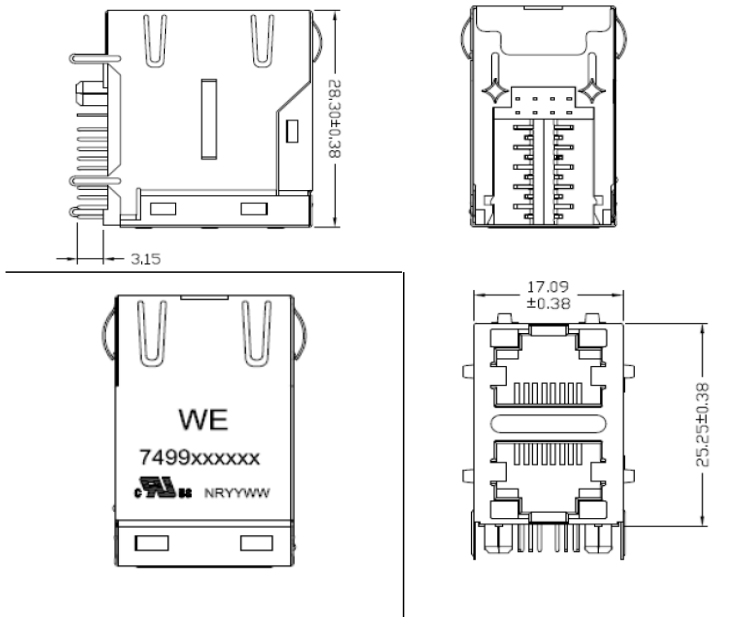

C Elektrische Eigenschaften / electrical properties :

Eigenschaften / properties	Testbedingungen / test conditions		Wert / value	Einheit / unit	tol.
Induktivität / Inductance	100kHz / 100mV @ 8mA DC-Bias	OCL	350	µH	min.
Übersetzungsverhältnis / Turns ratio	100kHz / 100mV	TR	1 : 1	Tx	3%
			1 : 1	Rx	
Insertion Loss	1-100MHz	IL	-1,1	dB	max.
Return Loss	1-30MHz @ 100Ω	RL	-18	dB	min.
	40-60MHz @ 100Ω		-14		
	60-80MHz @ 100Ω		-12		
	80-100MHz @ 100Ω		-10		
Crosstalk	1-10MHz	CT	-35	dB	min.
	15-60MHz		-26		
	60-100MHz		-24		
Common Mode Rejection	1-60MHz	CMR	-40	dB	min.
	60-100MHz		-30		

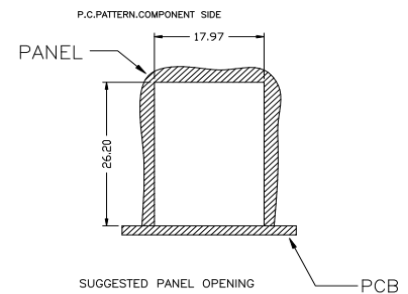

D Prüfgeräte / test equipment :

HP4395A

E Testbedingungen / test conditions :

Luftfeuchtigkeit / humidity: 33%
 Umgebungstemperatur / temperature: +25°C

F Werkstoffe & Zulassungen / material & approvals :

Basismaterial / base material: Ferrit / ferrite
 Draht / wire: UEW/Y 155°C
 Kontaktmaterial/ contact plating: 100% tin w. nickel underpalting
 30µ"gold plating on contact area
 Gehäuse / housing: Thermoplastic UL-94V0
 LED: 1,8-2,8 V / 20mA
 Shield: 50µ" nickel over 0.01" cooper alloy

G Eigenschaften / general specifications :

Betriebstemp. / operating temperature: -40 °C to +85 °C
 Hochspannungsprüfung / Hipot test: 1500Vrms 1min.
 Geeignet für 1000BaseT-Anwendungen gemäß IEEE 802.3ab /
 Compliant with IEEE 802.3ab for 1000BaseT

Freigabe erteilt / general release:

Kunde / customer

Datum / date

Unterschrift / signature

Würth Elektronik

Geprüft / checked

Kontrolliert / approved

Name	Änderung / modification	Datum / date
JaB	Revision 04	2015-01-26
Mle	Revision 03	2013-06-05
Mru	Revision 02	2013-05-13
Mle	Revision 01	2013-02-07
Mle	Revision 00	2012-06-18

Würth Elektronik eiSos GmbH & Co.KG

D-74638 Waldenburg · Max-Eyth-Straße 1 - 3 · Germany · Telefon (+49) (0) 7942 - 945 - 0 · Telefax (+49) (0) 7942 - 945 - 400
<http://www.we-online.com>

Spezifikation für Freigabe / specification for release

Kunde / customer :

Artikelnummer / part number :

7499151120



Bezeichnung : **LAN-Übertrager WE-RJ45LAN 10/100/1000 BaseT**

description : **LAN-Transformer WE-RJ45LAN 10/100/1000 BaseT**

DATUM / DATE : 2015-01-26

H Schaltbild / Schematics :

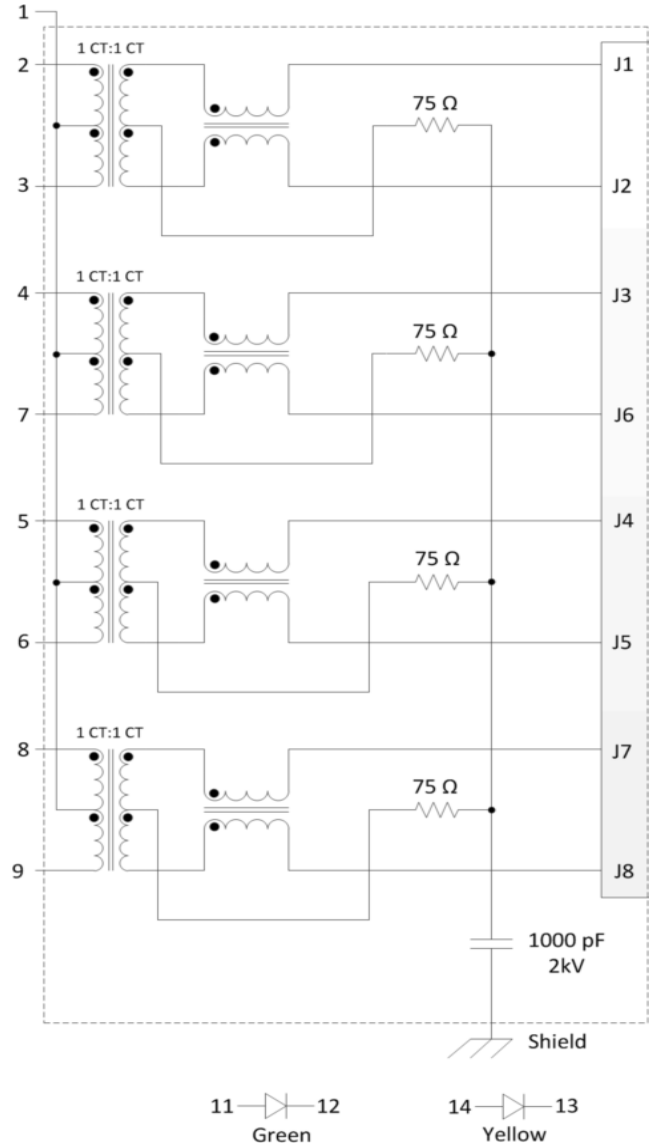

Freigabe erteilt / general release:	Kunde / customer		
.....		
Datum / date	Unterschrift / signature	JaB	Revision 04
.....	Würth Elektronik	Mle	Revision 03
.....	Mru	Revision 02
Geprüft / checked	Kontrolliert / approved	Mle	Revision 01
.....	Mle	Revision 00
		Name	Änderung / modification
			Datum / date

Würth Elektronik eiSos GmbH & Co.KG

D-74638 Waldenburg · Max-Eyth-Straße 1 - 3 · Germany · Telefon (+49) (0) 7942 - 945 - 0 · Telefax (+49) (0) 7942 - 945 - 400
<http://www.we-online.com>

Spezifikation für Freigabe / specification for release

Kunde / customer :

Artikelnummer / part number :

7499151120



Bezeichnung : **LAN-Übertrager WE-RJ45LAN 10/100/1000 BaseT**

description : **LAN-Transformer WE-RJ45LAN 10/100/1000 BaseT**

DATUM / DATE : 2015-01-26

I Verpackungsspezifikation / package specification :

Tube

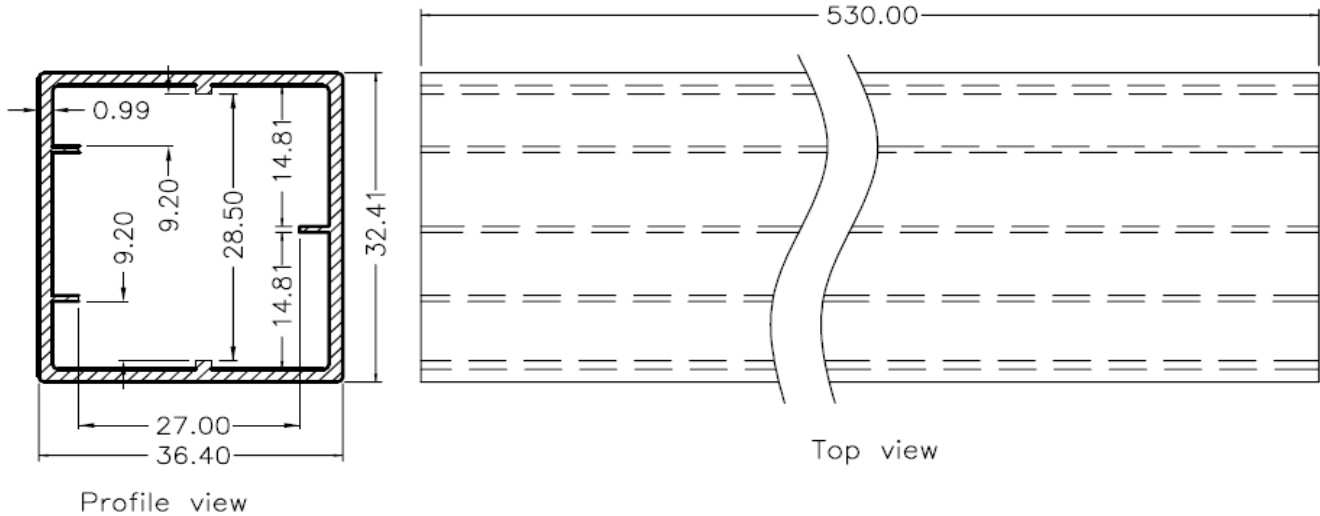

Carton

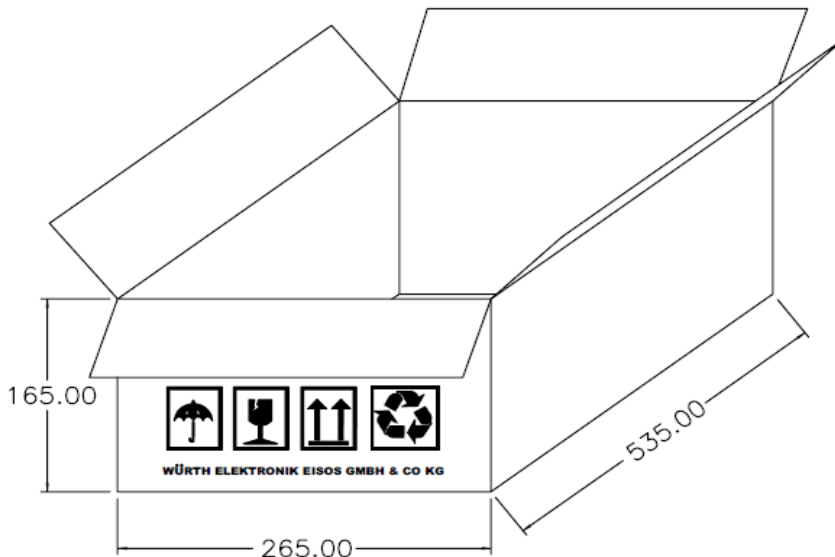

Package Quantity:

tube= 26pcs
carton= 832pcs

dimensions in mm

Freigabe erteilt / general release:	Kunde / customer			
.....			
Datum / date	Unterschrift / signature	JaB	Revision 04	2015-01-26
.....	Würth Elektronik	Mle	Revision 03	2013-06-05
.....	Mru	Revision 02	2013-05-13
Geprüft / checked	Kontrolliert / approved	Mle	Revision 01	2013-02-07
.....	Mle	Revision 00	2012-06-18
		Name	Änderung / modification	Datum / date

This electronic component has been designed and developed for usage in general electronic equipment. Before incorporating this component into any equipment where higher safety and reliability is especially required or if there is the possibility of direct damage or injury to human body, for example in the range of aerospace, aviation, nuclear control, submarine, transportation, (automotive control, train control, ship control), transportation signal, disaster prevention, medical, public information network etc, Würth Elektronik eiSos GmbH must be informed before the design-in stage. In addition, sufficient reliability evaluation checks for safety must be performed on every electronic component which is used in electrical circuits that require high safety and reliability functions or performance.

Würth Elektronik eiSos GmbH & Co.KG

D-74638 Waldenburg · Max-Eyth-Straße 1 - 3 · Germany · Telefon (+49) (0) 7942 - 945 - 0 · Telefax (+49) (0) 7942 - 945 - 400
<http://www.we-online.com>