

CKT	A	B	SLOTS LOCATION
02	4.93 .194	2.54 ± 0.05 .100 ± .002	NONE
03	7.47 .294	5.08 ± 0.10 .200 ± .004	NONE
04	10.01 .394	7.62 ± 0.15 .300 ± .006	NONE
05	12.55 .494	10.16 ± 0.15 .400 ± .006	NONE
06	15.09 .594	12.70 ± 0.18 .500 ± .007	4, 5
07	17.63 .694	15.24 ± 0.18 .600 ± .007	4, 5
08	20.17 .794	17.78 ± 0.20 .700 ± .008	4, 5
09	22.71 .894	20.32 ± 0.20 .800 ± .008	4, 5
10	25.25 .994	22.86 ± 0.23 .900 ± .009	4, 5
11	27.79 1.094	25.40 ± 0.23 1.000 ± .009	4, 5 8, 9
12	30.33 1.194	27.94 ± 0.25 1.100 ± .010	4, 5 8, 9

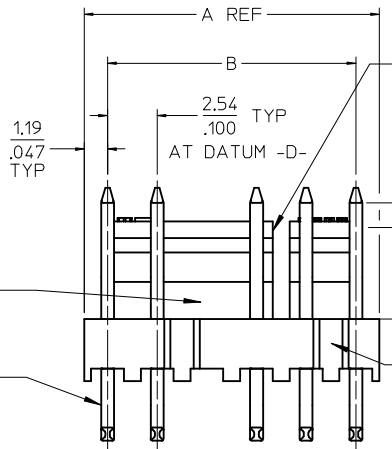
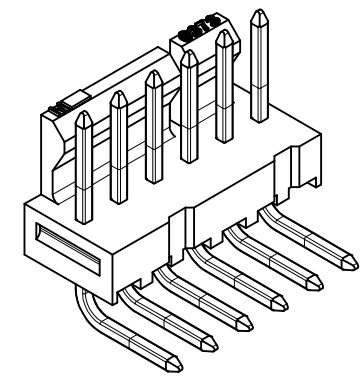
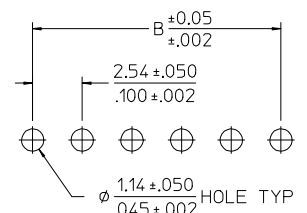
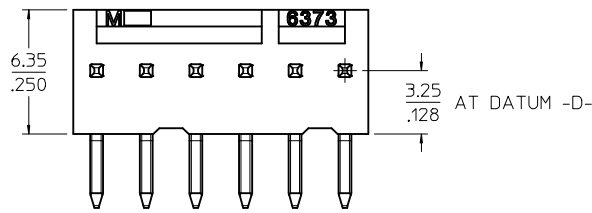

SLOTS LOCATED BETWEEN CIRCUITS (SEE CHART)

1.3 CENTERLINE OF PIN IN AREA SHOWN NOT .05 TO VARY FROM CENTERLINE OF PIN AT DATUM -D- BY MORE THAN 0.20/.008 IN ANY DIRECTION.

OPTIONAL VOIDED CIRCUIT SEE CHART FOR LOCATION

CIRCUIT #1 REF. SEE NOTE 7

RECESSED GATE MAY BE PRESENT ON 2-12 CIRCUIT PARTS. LOCATION VARIES.

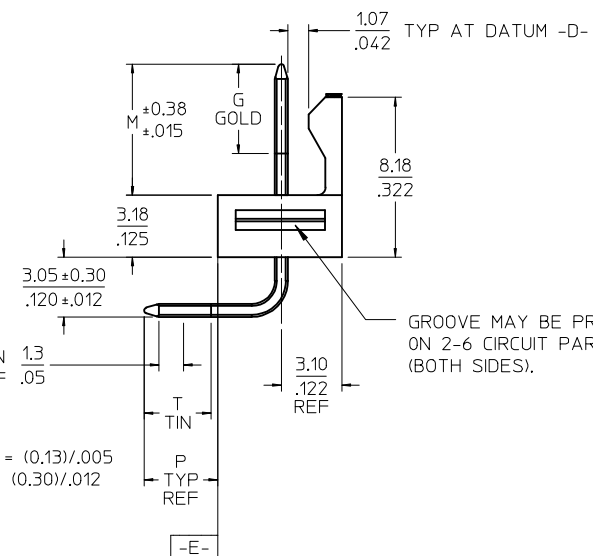

GROOVE MAY BE PRESENT ON 2-6 CIRCUIT PARTS (BOTH SIDES).

CENTERLINE OF PIN IN AREA SHOWN NOT TO VARY FROM CENTERLINE OF PIN AT DATUM -E- BY MORE THAN *** IN ANY DIRECTION.

DIMENSION P UNDER (3.58)/.141 = (0.13)/.005

DIMENSION P OVER (3.61)/.142 = (0.30)/.012

- NOTES:
- MATERIAL: HOUSING: NYLON, UL 94V-2, IEC 60335-1 5TH EDITION GLOW WIRE CAPABLE, COLOR: BLACK
PINS: BRASS
 - FINISH:
(197) = OVERALL REFLOWED MATTE TIN: 0.00152/.000060 MIN OVER 0.00127/.000050 MIN NICKEL.
(208) = SELECT GOLD: 0.00038/.000015 MIN, SELECT MATTE TIN: 0.00254/.000100 MIN, BOTH OVER 0.00127/.000050 MIN NICKEL.
(228) = SELECT GOLD: 0.00076/.000030 MIN, SELECT MATTE TIN: 0.00254/.000100 MIN, BOTH OVER 0.00127/.000050 MIN NICKEL.
 - PRODUCT SPECIFICATION AND PROCESS PARAMETERS: PS-171856-0001, PS-171856-0002
 - PACKAGING INFORMATION: SEE CHART.
 - MATES WITH 4455, 2695, 6471 SERIES
 - PARTS ARE STACKABLE END TO END ON 2.54/.100 CENTERS.
 - CIRCUIT ONE DESIGNATION IS USED TO DEFINE VOID LOCATION. CIRCUIT ONE MAY OR MAY NOT LINE UP WITH CIRCUIT ONE ON THE MATING HOUSING.
 - PIN PUSHOUT FORCE: 2 LBS MIN.
 - THIS PART CONFORMS TO CLASS B REQUIREMENTS OF COSMETIC SPECIFICATION PS-45499-002.

ADD PART NUMBERS	EC NO: UCP2015-1230	2014/09/23
	DRW:MKIPPER	2014/09/23
	CHKD:NGUYEN	2014/09/23
	APPR:FSMITH	2014/10/01
DESCRIPTION	REV	
1	A3	A3
2	A3	A3
SHT	REV	

QUALITY SYMBOLS	▽/E=0
	▽/E=0
	▽/E=0

GENERAL TOLERANCES (UNLESS SPECIFIED)	
	mm INCH
4 PLACES	± --- ± ---
3 PLACES	± --- ± .010
2 PLACES	± 0.25 ± .015
1 PLACE	± 0.38 ± ---
0 PLACE	± ±
ANGULAR ± 1/2°	
DRAFT WHERE APPLICABLE MUST REMAIN WITHIN DIMENSIONS	

DIMENSION STYLE	
MM/IN	
DRAWN BY	DATE
MKIPPER	2012/12/05
CHECKED BY	DATE
SSOUSEK	2012/12/12
APPROVED BY	DATE
FSMITH	2013/06/11
MATERIAL NO.	
SEE CHART	
SIZE	B

SCALE	4:1	DESIGN UNITS	INCH	THIRD ANGLE PROJECTION
TITLE				
KK RPC .100 RIGHT ANGLE HEADER ASSEMBLY FRICTION LOCK				
molex				
DOCUMENT NO.			SHEET NO.	
SD-171857-0001			1 OF *	
THIS DRAWING CONTAINS INFORMATION THAT IS PROPRIETARY TO MOLEX INCORPORATED AND SHOULD NOT BE USED WITHOUT WRITTEN PERMISSION				

GROUP:	171857-0002/-0012			
PLATING:	197			
MATING: (M)	6.73 / .265			
DIM. G:	N/A			
PC TAIL: (P)	2.54 / .100			
DIM T:	OVERALL			
PACKAGING:	PK-7478-001 BULK			
CKTS	MATERIAL NUMBER	CKTS	MATERIAL NUMBER	VOID CKT
2	171857-0002			
3	171857-0003			
4	171857-0004			
5	171857-0005			
6	171857-0006			
7	171857-0007			
8	171857-0008			
9	171857-0009			
10	171857-0010			
11	171857-0011			
12	171857-0012			

GROUP:	171857-1002/-1012			
PLATING:	208			
MATING: (M)	6.73 / .265			
DIM. G:	5.08 / .200			
PC TAIL: (P)	2.54 / .100			
DIM T:	3.43 / .135			
PACKAGING:	PK-7478-001 BULK			
CKTS	MATERIAL NUMBER	CKTS	MATERIAL NUMBER	VOID CKT
2	171857-1002			
3	171857-1003			
4	171857-1004			
5	171857-1005			
6	171857-1006			
7	171857-1007			
8	171857-1008			
9	171857-1009			
10	171857-1010			
11	171857-1011			
12	171857-1012			

GROUP:	171857-2002/-2012			
PLATING:	228			
MATING: (M)	6.73 / .265			
DIM. G:	5.08 / .200			
PC TAIL: (P)	2.54 / .100			
DIM T:	3.43 / .135			
PACKAGING:	PK-7478-001 BULK			
CKTS	MATERIAL NUMBER	CKTS	MATERIAL NUMBER	VOID CKT
2	171857-2002			
3	171857-2003			
4	171857-2004			
5	171857-2005			
6	171857-2006			
7	171857-2007			
8	171857-2008			
9	171857-2009			
10	171857-2010			
11	171857-2011			
12	171857-2012			

REV: A3	ECR/ECN INFORMATION: EC No.: UCP2015-1230 DATE: 10/14/2014	TITLE: KK RPC 100 RIGHT ANGLE HEADER ASSEMBLY, FRICTION LOCK	SHEET No. - 2 -
DOCUMENT NUMBER: SD - 171857 - 0001		CREATED / REVISED BY: MKIPPER	CHECKED BY: NNGUYEN
		APPROVED BY: FSMITH	

GROUP:	171857-0102/-0112			
PLATING:	197			
MATING: (M)	6.71 / .264			
DIM. G:	N/A			
PC TAIL: (P)	3.58 / .141			
DIM T:	OVERALL			
PACKAGING:	PK-7478-001 BULK			
CKTS	MATERIAL NUMBER	CKTS	MATERIAL NUMBER	VOID CKT
2	171857-0102			
3	171857-0103			
4	171857-0104			
5	171857-0105			
6	171857-0106			
7	171857-0107			
8	171857-0108			
9	171857-0109			
10	171857-0110			
11	171857-0111			
12	171857-0112			

GROUP:	171857-1102/-1112			
PLATING:	208			
MATING: (M)	6.71 / .264			
DIM. G:	4.57 / .180			
PC TAIL: (P)	3.58 / .141			
DIM T:	3.43 / .135			
PACKAGING:	PK-7478-001 BULK			
CKTS	MATERIAL NUMBER	CKTS	MATERIAL NUMBER	VOID CKT
2	171857-1102			
3	171857-1103			
4	171857-1104			
5	171857-1105			
6	171857-1106			
7	171857-1107			
8	171857-1108			
9	171857-1109			
10	171857-1110			
11	171857-1111			
12	171857-1112			

GROUP:				
PLATING:				
MATING: (M)				
DIM. G:				
PC TAIL: (P)				
DIM T:				
PACKAGING:				
CKTS	MATERIAL NUMBER	CKTS	MATERIAL NUMBER	VOID CKT
2				
3				
4				
5				
6				
7				
8				
9				
10				
11				
12				

REV: A3	ECR/ECN INFORMATION: EC No.: UCP2015-1230 DATE: 10/14/2014	TITLE: KK RPC 100 RIGHT ANGLE HEADER ASSEMBLY, FRICTION LOCK	SHEET No. - 3 -
DOCUMENT NUMBER: SD - 171857 - 0001		CREATED / REVISED BY: MKIPPER	CHECKED BY: NNGUYEN
		APPROVED BY: FSMITH	

GROUP:	171857-3002/-3012			
PLATING:	197			
MATING: (M)	6.73 / .265			
DIM. G:	N/A			
PC TAIL: (P)	2.54 / .100			
DIM T:	OVERALL			
PACKAGING:	PK-171857-0001 TAPE AND REEL			
CKTS	MATERIAL NUMBER	CKTS	MATERIAL NUMBER	VOID CKT
2	171857-3002			
3	171857-3003			
4	171857-3004			
5	171857-3005			
6	171857-3006			
7	171857-3007			
8	171857-3008			
9	171857-3009			
10	171857-3010			
11	171857-3011			
12	171857-3012			

GROUP:	171857-4002/-4012			
PLATING:	208			
MATING: (M)	6.73 / .265			
DIM. G:	5.08 / .200			
PC TAIL: (P)	2.54 / .100			
DIM T:	3.43 / .135			
PACKAGING:	PK-171857-0001 TAPE AND REEL			
CKTS	MATERIAL NUMBER	CKTS	MATERIAL NUMBER	VOID CKT
2	171857-4002			
3	171857-4003			
4	171857-4004			
5	171857-4005			
6	171857-4006			
7	171857-4007			
8	171857-4008			
9	171857-4009			
10	171857-4010			
11	171857-4011			
12	171857-4012			

GROUP:				
PLATING:				
MATING: (M)				
DIM. G:				
PC TAIL: (P)				
DIM T:				
PACKAGING:				
CKTS	MATERIAL NUMBER	CKTS	MATERIAL NUMBER	VOID CKT
2				
3				
4				
5				
6				
7				
8				
9				
10				
11				
12				

REV: A3	ECR/ECN INFORMATION: EC No.: UCP2015-1230 DATE: 10/14/2014	TITLE: KK RPC 100 RIGHT ANGLE HEADER ASSEMBLY, FRICTION LOCK	SHEET No. - 4 -
DOCUMENT NUMBER: SD - 171857 - 0001		CREATED / REVISED BY: MKIPPER	CHECKED BY: NNGUYEN
		APPROVED BY: FSMITH	

GROUP:	171857-0002/-0012			
PLATING:	197			
MATING: (M)	6.73 / .265			
DIM. G:	N/A			
PC TAIL: (P)	2.54 / .100			
DIM T:	OVERALL			
PACKAGING:	PK-7478-001 BULK			
CKTS	MATERIAL NUMBER	CKTS	MATERIAL NUMBER	VOID CKT
2	171857-0002			
3	171857-0003			
4	171857-0004			
5	171857-0005			
6	171857-0006			
7	171857-0007			
8	171857-0008			
9	171857-0009			
10	171857-0010			
11	171857-0011			
12	171857-0012			

GROUP:	171857-1002/-1012			
PLATING:	208			
MATING: (M)	6.73 / .265			
DIM. G:	5.08 / .200			
PC TAIL: (P)	2.54 / .100			
DIM T:	3.43 / .135			
PACKAGING:	PK-7478-001 BULK			
CKTS	MATERIAL NUMBER	CKTS	MATERIAL NUMBER	VOID CKT
2	171857-1002			
3	171857-1003			
4	171857-1004			
5	171857-1005			
6	171857-1006			
7	171857-1007			
8	171857-1008			
9	171857-1009			
10	171857-1010			
11	171857-1011			
12	171857-1012			

GROUP:	171857-2002/-2012			
PLATING:	228			
MATING: (M)	6.73 / .265			
DIM. G:	5.08 / .200			
PC TAIL: (P)	2.54 / .100			
DIM T:	3.43 / .135			
PACKAGING:	PK-7478-001 BULK			
CKTS	MATERIAL NUMBER	CKTS	MATERIAL NUMBER	VOID CKT
2	171857-2002			
3	171857-2003			
4	171857-2004			
5	171857-2005			
6	171857-2006			
7	171857-2007			
8	171857-2008			
9	171857-2009			
10	171857-2010			
11	171857-2011			
12	171857-2012			

REV: A3	ECR/ECN INFORMATION: EC No.: UCP2015-1230 DATE: 10/14/2014	TITLE: KK RPC 100 RIGHT ANGLE HEADER ASSEMBLY, FRICTION LOCK	SHEET No. - 2 -
DOCUMENT NUMBER: SD - 171857 - 0001		CREATED / REVISED BY: MKIPPER	CHECKED BY: NNGUYEN
		APPROVED BY: FSMITH	

GROUP:	171857-0102/-0112			
PLATING:	197			
MATING: (M)	6.71 / .264			
DIM. G:	N/A			
PC TAIL: (P)	3.58 / .141			
DIM T:	OVERALL			
PACKAGING:	PK-7478-001 BULK			
CKTS	MATERIAL NUMBER	CKTS	MATERIAL NUMBER	VOID CKT
2	171857-0102			
3	171857-0103			
4	171857-0104			
5	171857-0105			
6	171857-0106			
7	171857-0107			
8	171857-0108			
9	171857-0109			
10	171857-0110			
11	171857-0111			
12	171857-0112			

GROUP:	171857-1102/-1112			
PLATING:	208			
MATING: (M)	6.71 / .264			
DIM. G:	4.57 / .180			
PC TAIL: (P)	3.58 / .141			
DIM T:	3.43 / .135			
PACKAGING:	PK-7478-001 BULK			
CKTS	MATERIAL NUMBER	CKTS	MATERIAL NUMBER	VOID CKT
2	171857-1102			
3	171857-1103			
4	171857-1104			
5	171857-1105			
6	171857-1106			
7	171857-1107			
8	171857-1108			
9	171857-1109			
10	171857-1110			
11	171857-1111			
12	171857-1112			

GROUP:				
PLATING:				
MATING: (M)				
DIM. G:				
PC TAIL: (P)				
DIM T:				
PACKAGING:				
CKTS	MATERIAL NUMBER	CKTS	MATERIAL NUMBER	VOID CKT
2				
3				
4				
5				
6				
7				
8				
9				
10				
11				
12				

REV: A3	ECR/ECN INFORMATION: EC No.: UCP2015-1230 DATE: 10/14/2014	TITLE: KK RPC 100 RIGHT ANGLE HEADER ASSEMBLY, FRICTION LOCK	SHEET No. - 3 -
DOCUMENT NUMBER: SD - 171857 - 0001		CREATED / REVISED BY: MKIPPER	CHECKED BY: NNGUYEN
		APPROVED BY: FSMITH	

GROUP:	171857-3002/-3012			
PLATING:	197			
MATING: (M)	6.73 / .265			
DIM. G:	N/A			
PC TAIL: (P)	2.54 / .100			
DIM T:	OVERALL			
PACKAGING:	PK-171857-0001 TAPE AND REEL			
CKTS	MATERIAL NUMBER	CKTS	MATERIAL NUMBER	VOID CKT
2	171857-3002			
3	171857-3003			
4	171857-3004			
5	171857-3005			
6	171857-3006			
7	171857-3007			
8	171857-3008			
9	171857-3009			
10	171857-3010			
11	171857-3011			
12	171857-3012			

GROUP:	171857-4002/-4012			
PLATING:	208			
MATING: (M)	6.73 / .265			
DIM. G:	5.08 / .200			
PC TAIL: (P)	2.54 / .100			
DIM T:	3.43 / .135			
PACKAGING:	PK-171857-0001 TAPE AND REEL			
CKTS	MATERIAL NUMBER	CKTS	MATERIAL NUMBER	VOID CKT
2	171857-4002			
3	171857-4003			
4	171857-4004			
5	171857-4005			
6	171857-4006			
7	171857-4007			
8	171857-4008			
9	171857-4009			
10	171857-4010			
11	171857-4011			
12	171857-4012			

GROUP:				
PLATING:				
MATING: (M)				
DIM. G:				
PC TAIL: (P)				
DIM T:				
PACKAGING:				
CKTS	MATERIAL NUMBER	CKTS	MATERIAL NUMBER	VOID CKT
2				
3				
4				
5				
6				
7				
8				
9				
10				
11				
12				

REV: A3	ECR/ECN INFORMATION: EC No.: UCP2015-1230 DATE: 10/14/2014	TITLE: KK RPC 100 RIGHT ANGLE HEADER ASSEMBLY, FRICTION LOCK	SHEET No. - 4 -
DOCUMENT NUMBER: SD - 171857 - 0001		CREATED / REVISED BY: MKIPPER	CHECKED BY: NNGUYEN
		APPROVED BY: FSMITH	