

THE INFORMATION CONTAINED HEREIN IS CONSIDERED "PROPRIETARY" TO BEL FUSE INC. AND SHALL NOT BE COPIED, REPRODUCED OR DISCLOSED WITHOUT THE WRITTEN APPROVAL OF BEL FUSE INC.

ELECTRICAL CHARACTERISTICS @ 25°C

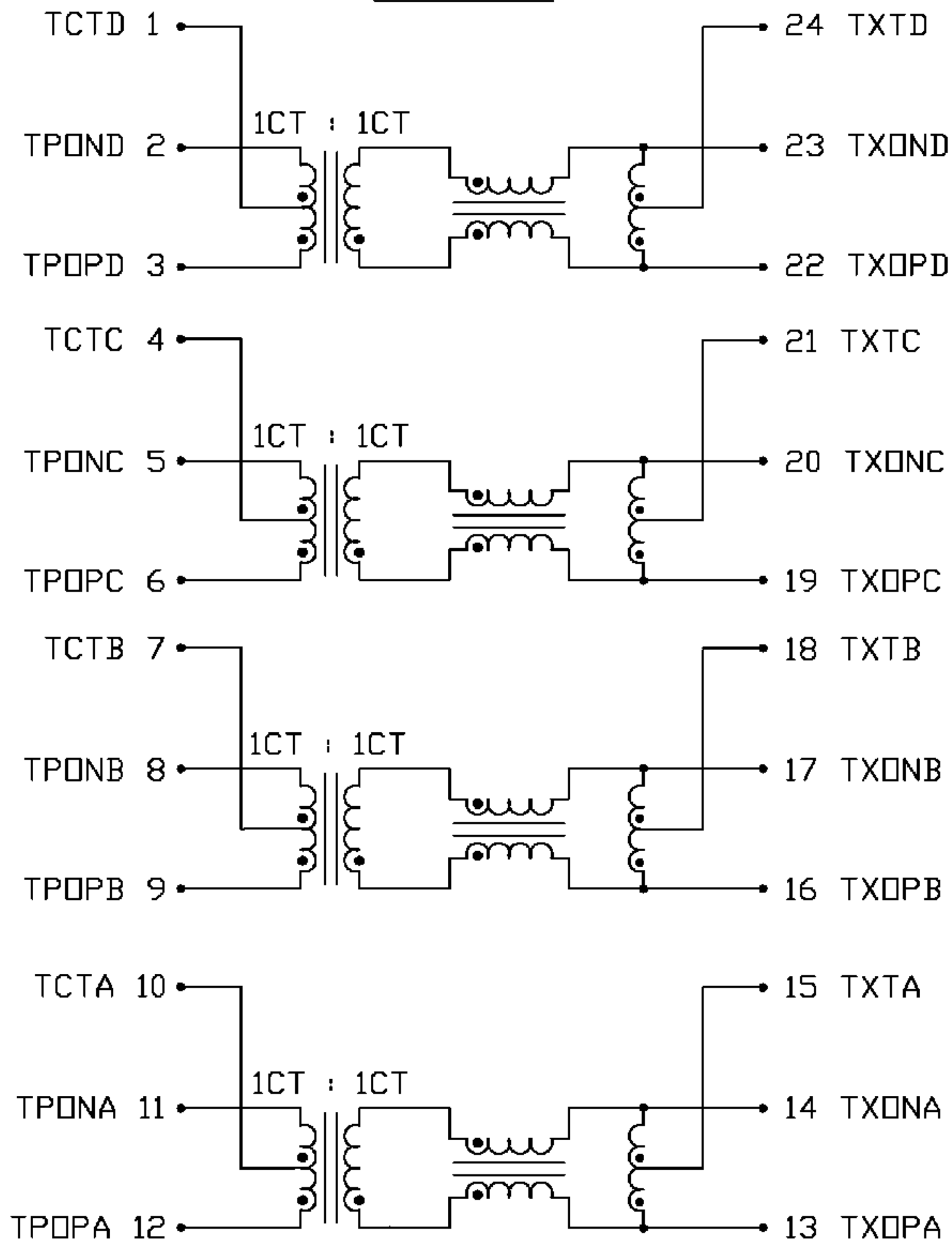

SCHEMATIC



TURNS RATIO

PIN(3-1-2) : (22-24-23)	1CT : 1CT
PIN(6-4-5) : (19-21-20)	1CT : 1CT
PIN(9-7-8) : (16-18-17)	1CT : 1CT
PIN(12-10-11) : (13-15-14)	1CT : 1CT

QCL

350μH MIN. AT 100 kHz, 100mV WITH 8mA DC BIAS @25°C

INSERTION LOSS

1.1dB MAX. @ 0.1 MHz  
0.5dB MAX. @ 1 MHz  
0.8dB MAX. @ 65 MHz  
1.0dB MAX. @ 100 MHz  
1.5dB MAX. @ 125 MHz

RETURN LOSS

UNDER 100 OHMS±15% ENVIRONMENT

18dB MIN. @ 0.5 TO 40 MHz  
12-20LOG (f/80 MHz) dBMIN.  
@ 40 TO 100 MHz

COMMON TO COMMON REJECTION

30dB MIN. @ 0.1 TO 100 MHz

CROSSTALK

@ 1-100 MHz  
33-20LOG (f/100 MHz) dB MIN.

HIPOT

PER HAND-WORK-03

ORIGINATED BY	DATE	TITLE	PART NO. / DRAWING NO.	STANDARD DIM.	[ ] METRIC DIM. AS REFERENCE	 COMPONENTS FOR A CONNECTED PLANET	
HO	08-08-06	ELECTRICAL SPECIFICATION	X5585999P3-F	TOL. IN INCH	UNIT : INCH [mm]		REV. : B
DRAWN BY	DATE	S558-5999-P3-F	FILE NAME	.X	SCALE : N/A		SIZE : A4
DQ Chen	08-08-06		X5585999P3FB.DWG	.XX			PAGE : 2

THE INFORMATION CONTAINED HEREIN IS CONSIDERED "PROPRIETARY" TO BEL FUSE INC. AND SHALL NOT BE COPIED, REPRODUCED OR DISCLOSED WITHOUT THE WRITTEN APPROVAL OF BEL FUSE INC.

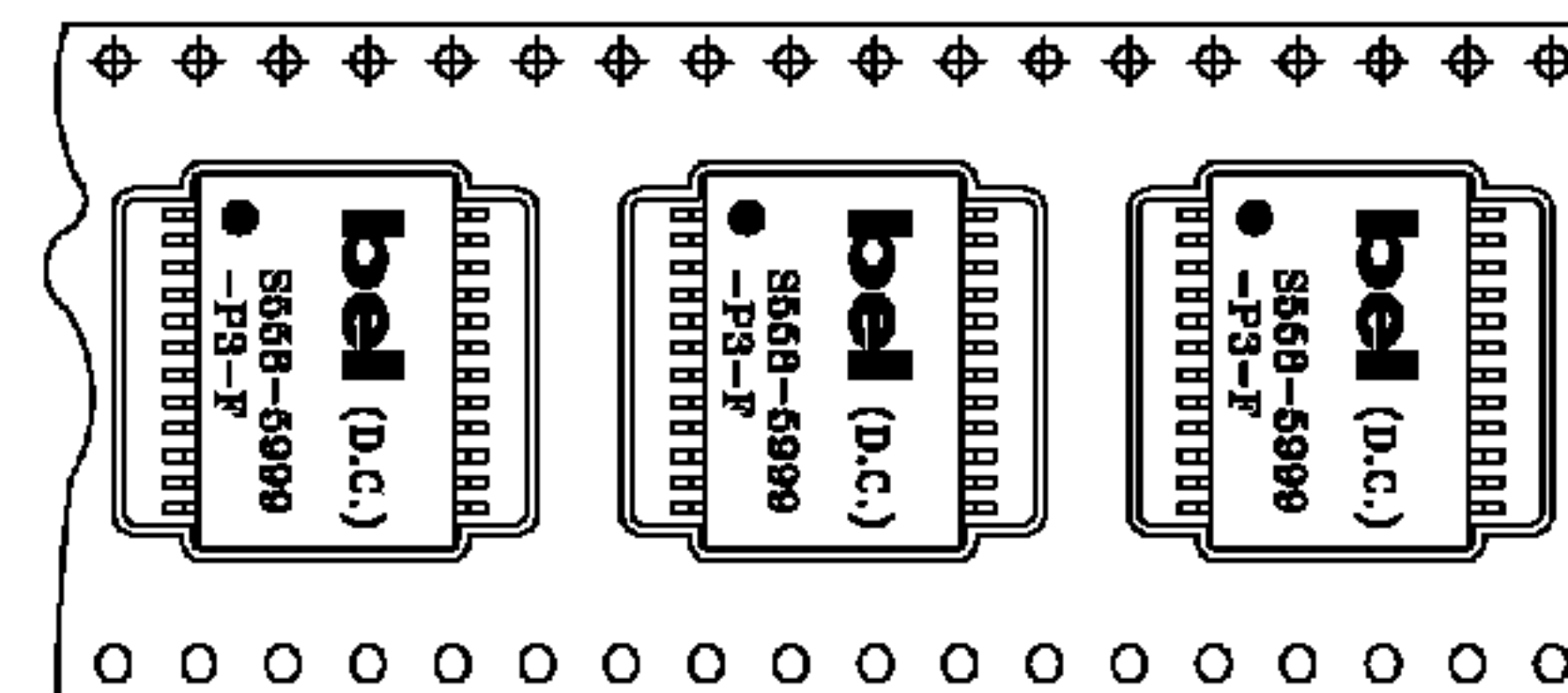
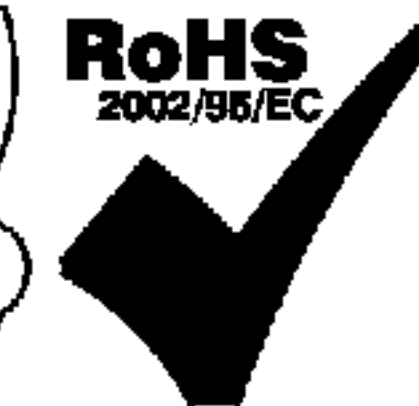

SUGGESTED PCB PAD LAYOUT

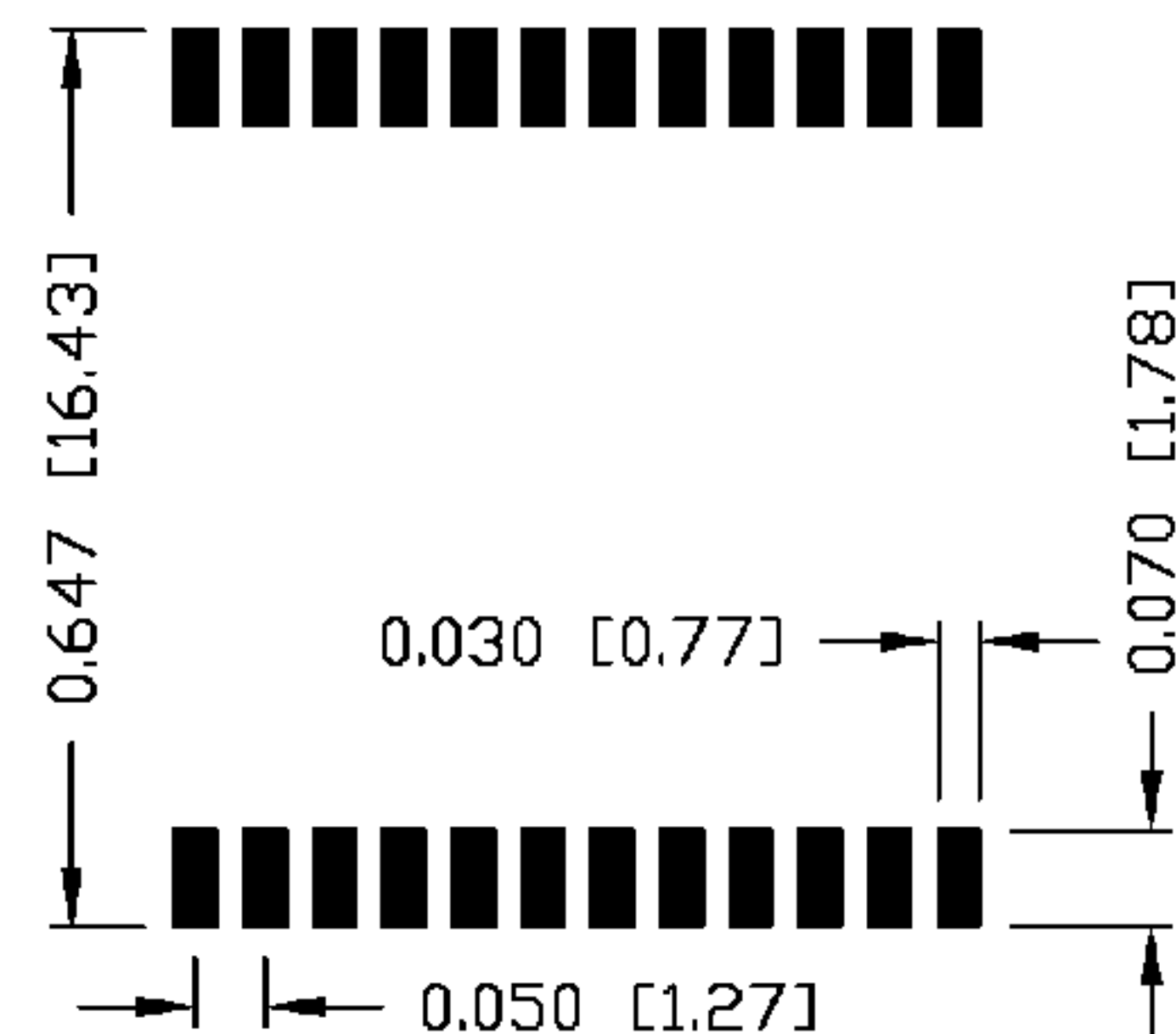

USER FEED DIRECTION  
ORIENTATION OF COMPONENT INSIDE POCKET

TAPE WIDTH	32MM
POCKET PITCH	24MM
QUANTITY OF COMPONENTS PER REEL	300
PLASTIC REEL OUTER DIAMETER	13 INCHES
PLASTIC REEL HUB DIAMETER	4 INCHES
COMPLY WITH EIA 481-2-A	

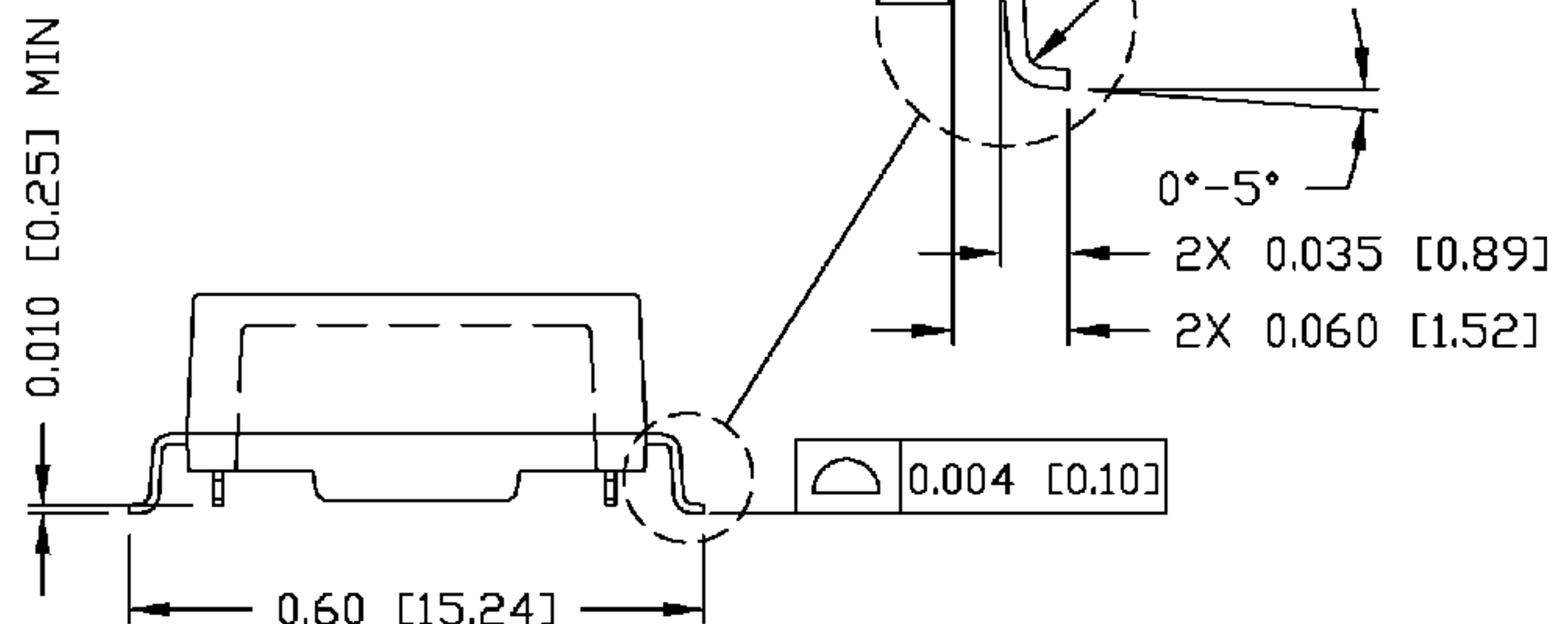
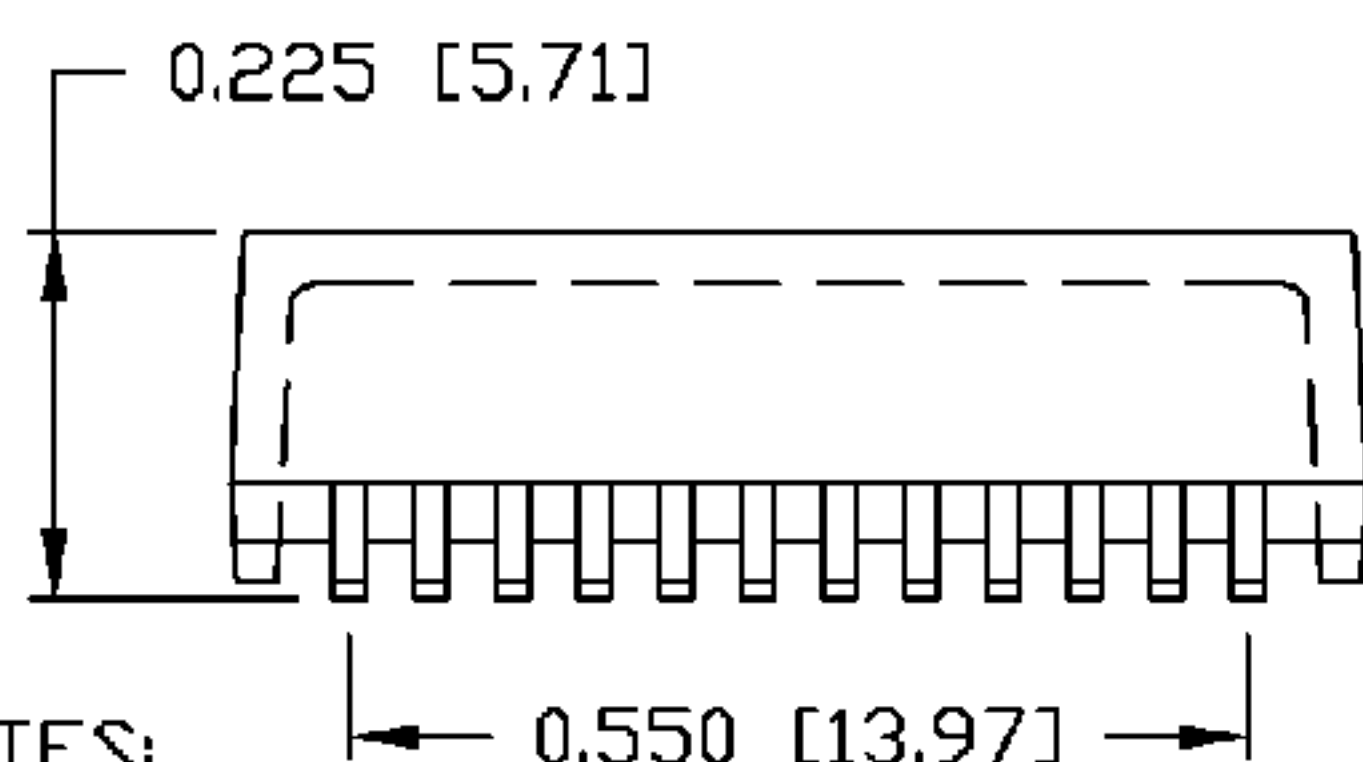
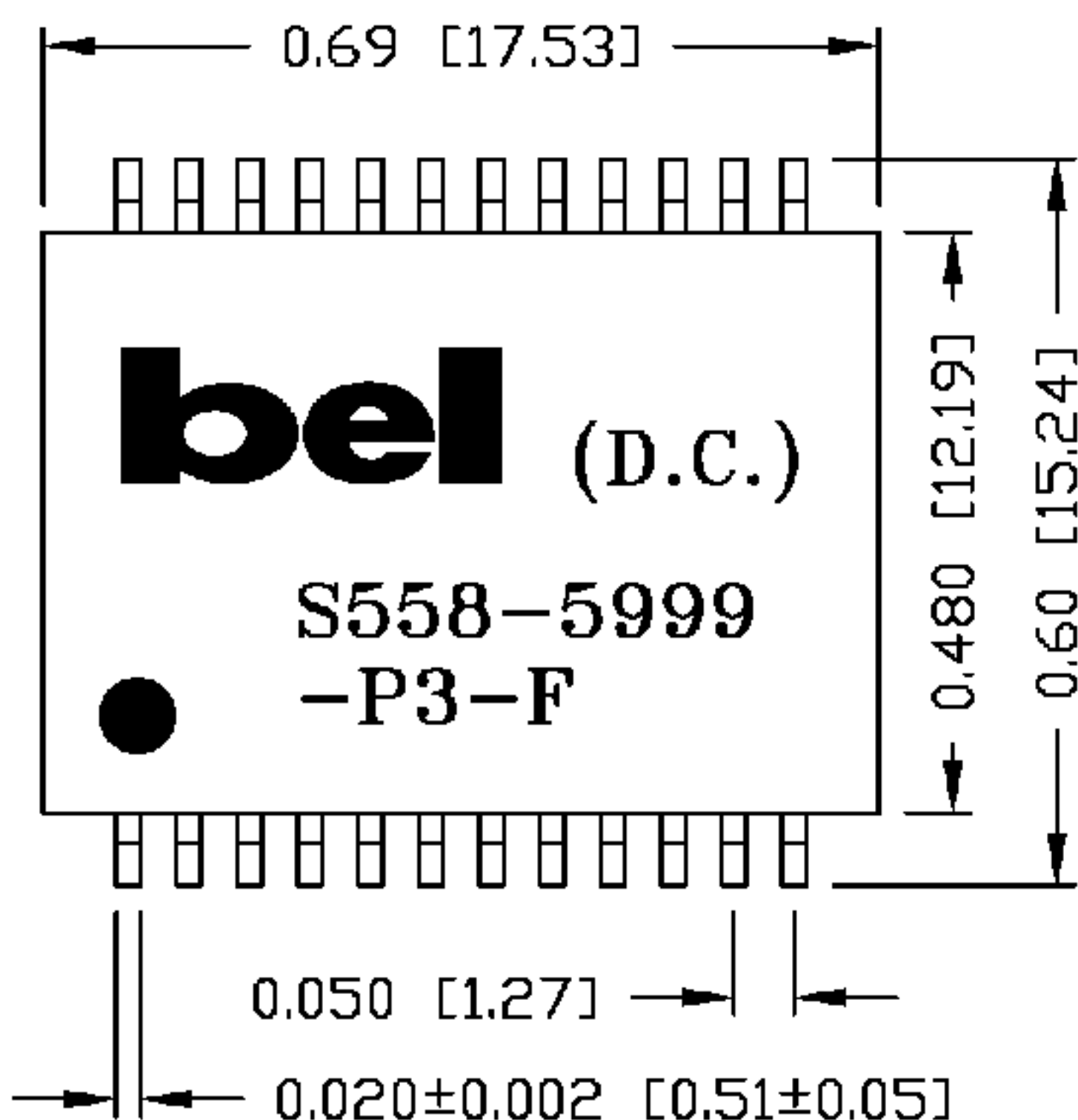

- NOTES:
- STANDARD MARKING REFER TO DOC. HAND-WORK-04.
  - PACKAGE CODE: "RQS001".

ORIGINATED BY	DATE	TITLE	PART NO. / DRAWING NO.	STANDARD DIM. TOL. IN INCH	[ ] METRIC DIM. AS REFERENCE	<p>COMPONENTS FOR A CONNECTED PLANET</p>
HO	08-08-06	MECHANICAL OUTLINE	X5585999P3-F	.X	UNIT : INCH [mm]	
DRAWN BY	DATE	S558-5999-P3-F	FILE NAME	.XX ±0.01	SCALE : N/A	
DQ Chen	08-08-06		X5585999P3FB.DWG	.XXX ±0.005	REV. : B SIZE : A4 PAGE : 3	