

1		2			3			4		
COUNT	DESCRIPTION OF REVISIONS	BY	CHKD	DATE	COUNT	DESCRIPTION OF REVISIONS	BY	CHKD	DATE	
△					△					
△					△					
△					△					

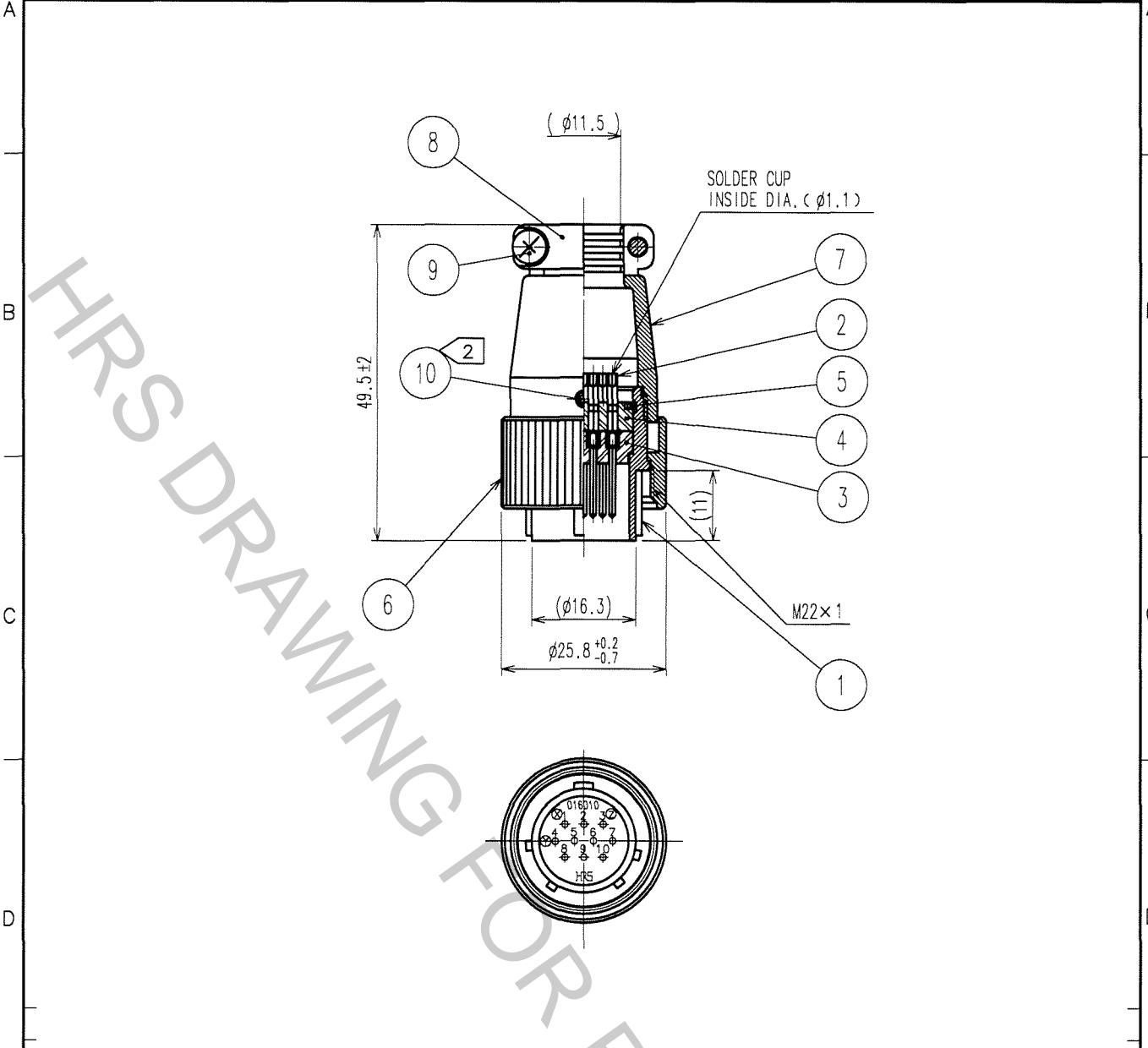

NOTES 1. ROTATION EXAMPLES OF REF.NO. ① AND ⑦ ARE SHOWN.
 ② ACROSS FLATS OF HEAGON HEAD OF REF.NO. ⑩ TO BE 1.27mm.

5	PHOSPHOR BRONZE	NICKEL PLATING	10	STEEL	NICKEL PLATING, HEX SOCKET SET SCREW M2.6×0.45×2
4	PHENOL FORMALDEHYDE	(BLACK) UL94V-0	9	BRASS	NICKEL PLATING M3×0.5×8
3	PHENOL FORMALDEHYDE	(BLACK) UL94V-0	8	ALUMINUM ALLOY	MATTE FINISH NICKEL PLATED
2	COPPER ALLOY	SILVER PLATING, 3μm min	7	ALUMINUM ALLOY	MATTE FINISH NICKEL PLATED
1	ALUMINUM ALLOY	MATTE FINISH NICKEL PLATED	6	ALUMINUM ALLOY	MATTE FINISH NICKEL PLATED
NO.	MATERIAL	FINISH, REMARKS	NO.	MATERIAL	FINISH, REMARKS

CODE NO. (OLD)		DRAWN	DESIGNED	CHECKED	APPROVED	RELEASED
		<i>J. Nozue</i>	<i>E. Kurii</i>		<i>M. Sato</i>	
		'06.3.26	'06.03.26		'06.03.27	
DRAWING NO. EDC4-024130-71			PART NO. JR16PK-10P(71)			
SCALE 1:1			CODE NO. CL114-0504-5-71			1/1
UNITS mm			HRS HIROSE ELECTRIC CO., LTD.			

TO
R