

DRAWING FILE NO. AB2-B0-24-450-1D1-C		REV 08-01-17
REVISIONS		
DATE	DESCRIPTION	
08-01-17	DRAWING CREATED	

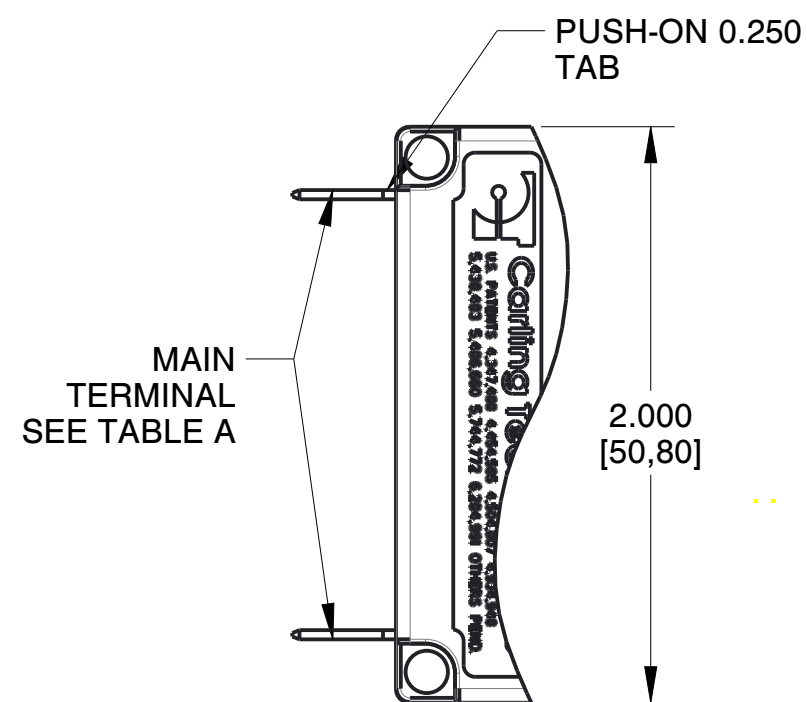

**TERMINAL DETAIL**

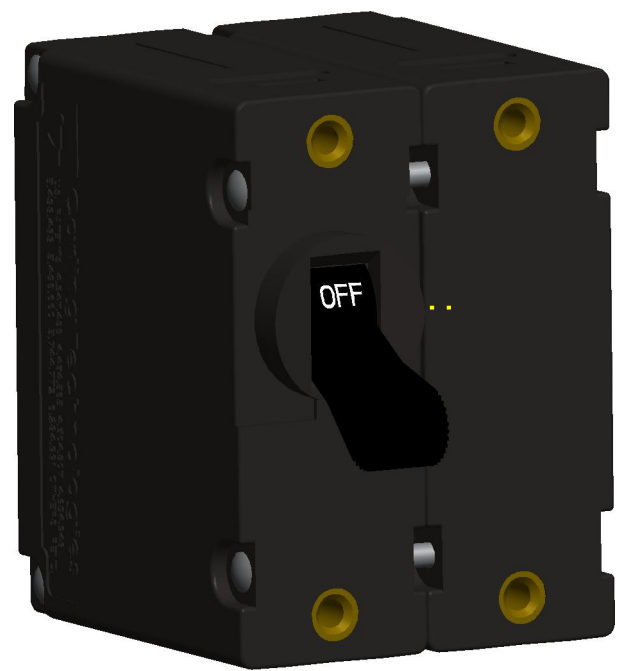
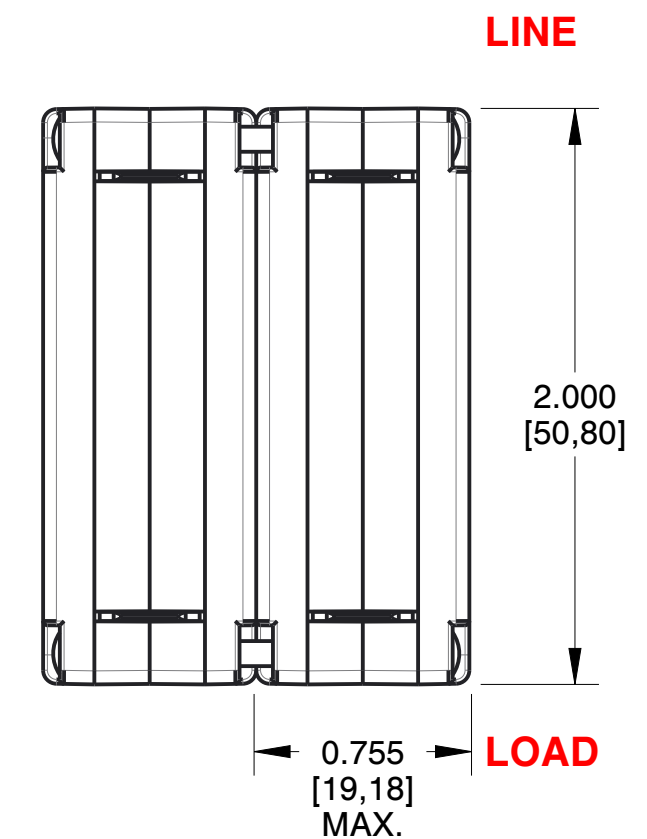
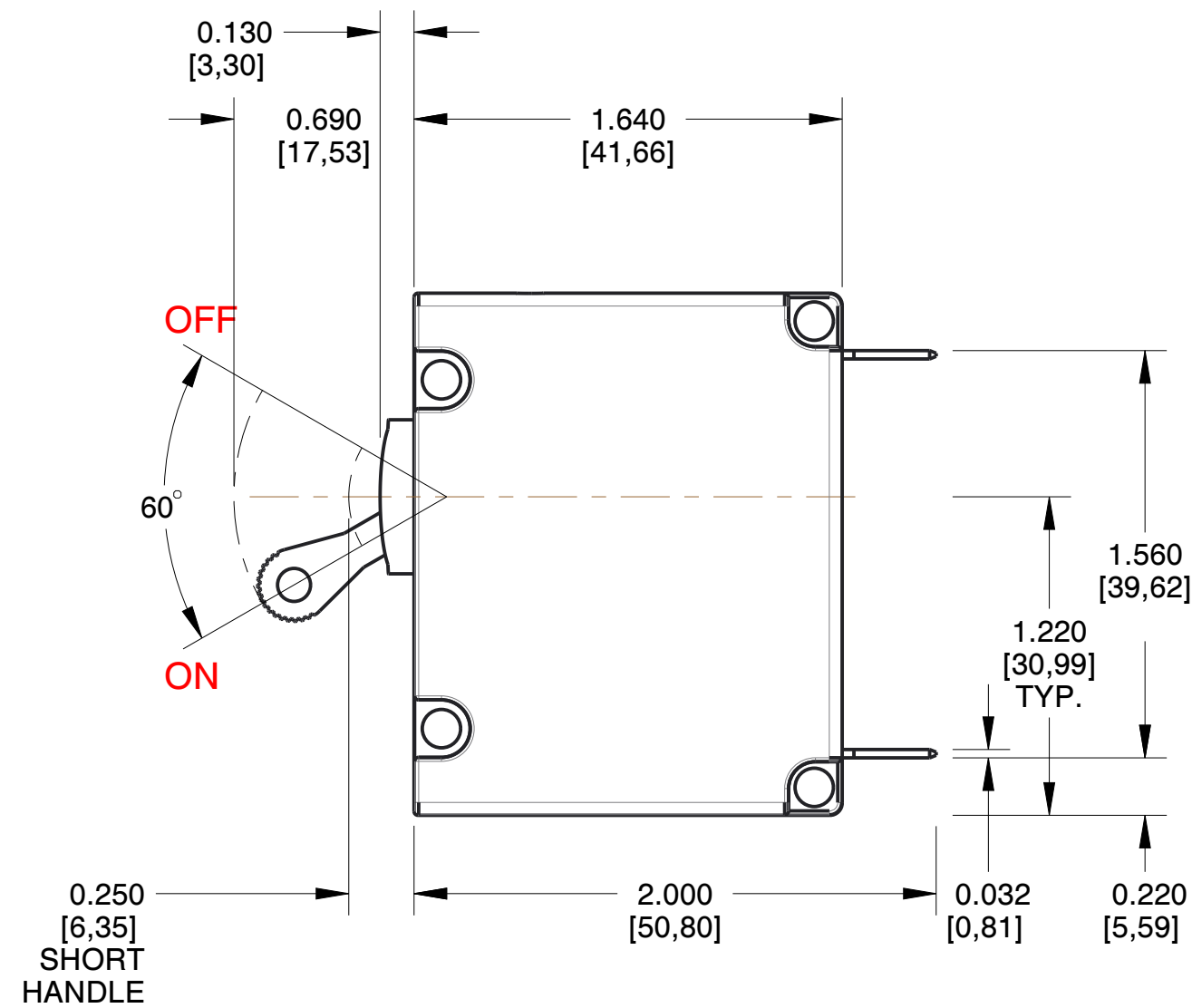
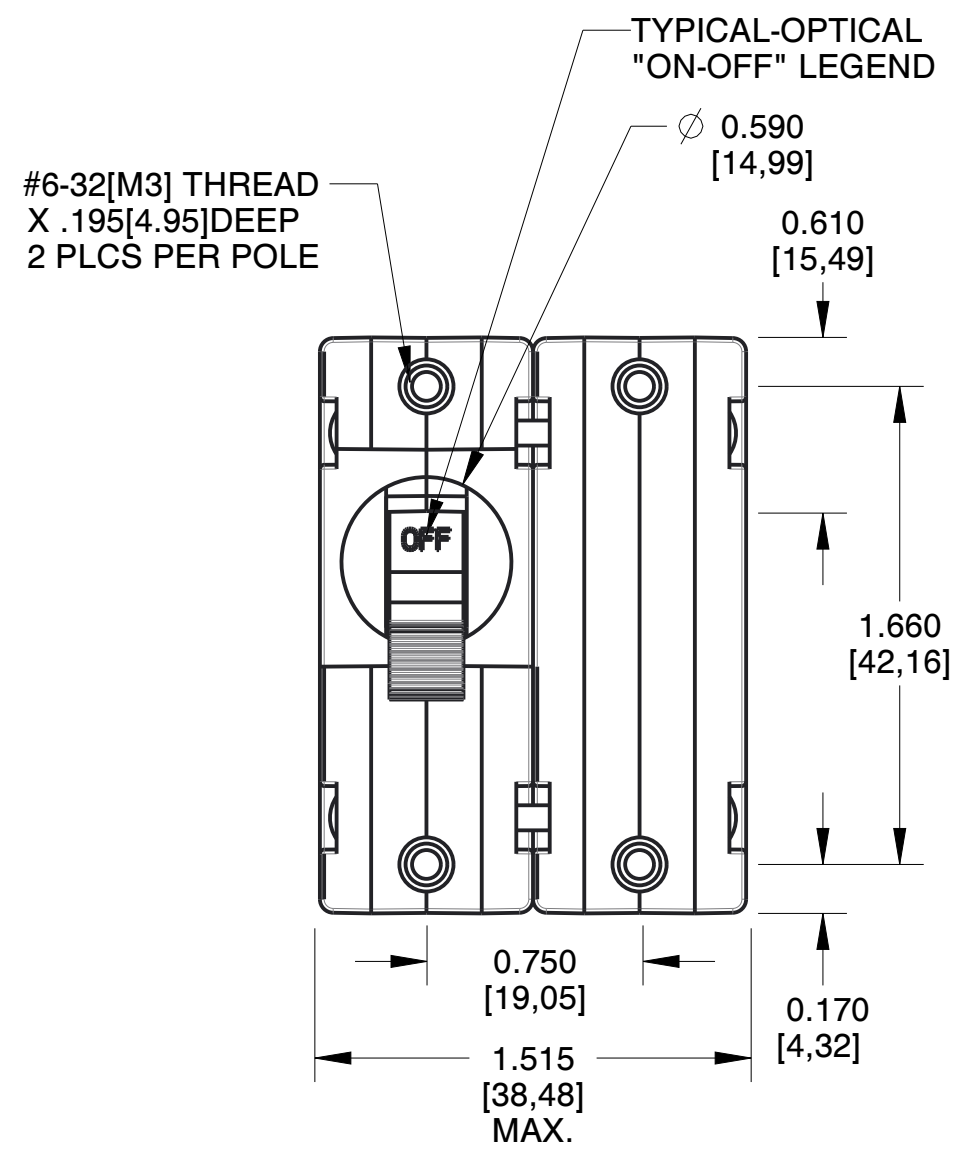
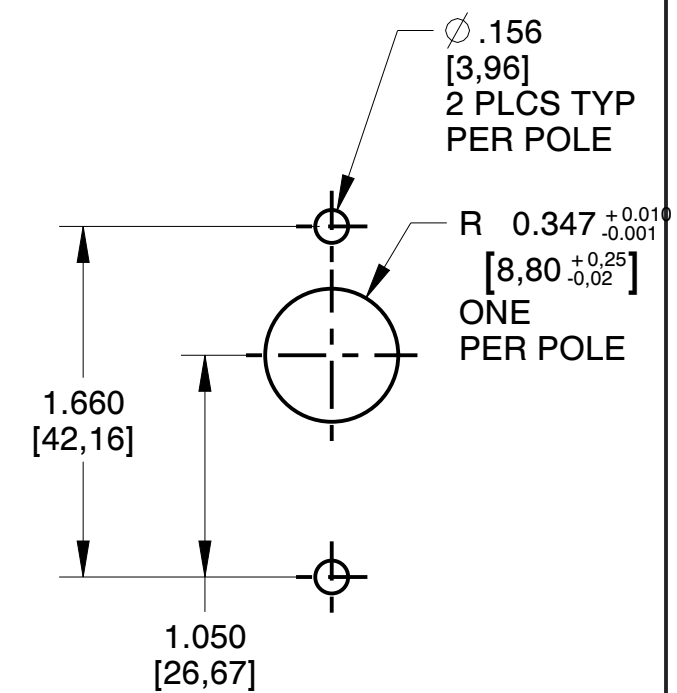
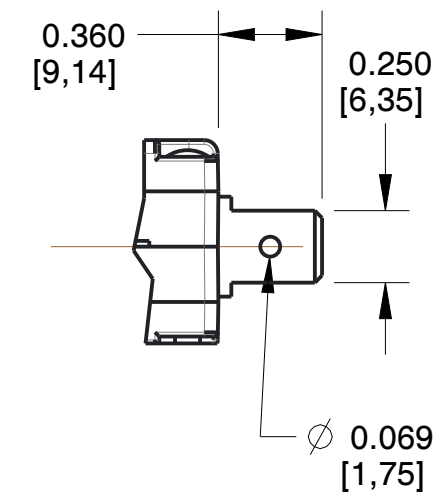

**PANEL CUTOUT DETAIL**

**Carling Technologies**  
Innovative Designs. Powerful Solutions.  
60 JOHNSON AVE  
PLAINVILLE, CT 06062, USA  
PHONE: (860) 793-9281  
SALES: SALES@CARLINGTECH.COM  
APPLICATION SUPPORT: TEAM2@CARLINGTECH.COM

CIRCUIT SCHEMATIC		TABLE A TIGHTENING TORQUE SPECIFICATIONS	
ANSI		THREAD SIZE	TORQUE
SERIES TRIP		#6-32 & M3 MOUNTING HARDWARE	7-9 IN-LBS [0.8-1.0 NM]
		#8-32 & M4 THREAD TERMINAL SCREW	12-15 IN-LBS [1.4-1.7 NM]
		#10-32 & M5 THREAD TERMINAL SCREW	15-20 IN-LBS [1.7-2.3 NM]

**PROPRIETARY NOTICE**  
NOTICE TO ALL PERSONS RECEIVING THIS DRAWING: THIS DOCUMENT IS THE PROPERTY OF CARLING TECHNOLOGIES, INC. AND IS NOT TO BE DISCLOSED, REPRODUCED IN WHOLE OR IN PART OR USED FOR MANUFACTURING PURPOSES BY ANYONE WITHOUT THE CONSENT OF CARLING TECHNOLOGIES, INC.

**DISCLAIMER**  
MANUFACTURER RESERVES THE RIGHT TO CHANGE PRODUCT SPECIFICATIONS WITHOUT PRIOR NOTICE.

**A-SERIES  
CIRCUIT\_BREAKER**

DO NOT SCALE DRAWING  
UNLESS OTHERWISE SPECIFIED  
DIMENSIONS: IN [MM]  
TOLERANCES: ± .020 [0.51]

DRAWING FILE NO. AB2-B0-24-450-1D1-C SIZE C  
PRODUCT SERIES: A-SERIES C.B. SHEET 1 OF 1