

- Notes.
- 1 Co-planarity is within 0.1 mm.
 - 2 As for part No.5 the performance remains good even if there are rubbing wounds by the assembly process. And the performance remains good though there might be a difference in the plating luster between each plating lots.
 - 3 Per reel : 400 pcs.
 - 4 Refer to the mated condition diagram for the panel thickness and layout.
 - 5 This product is mounted by reflow soldering. Refer to specification sheet ELC-129430-00-00 for reflow soldering.

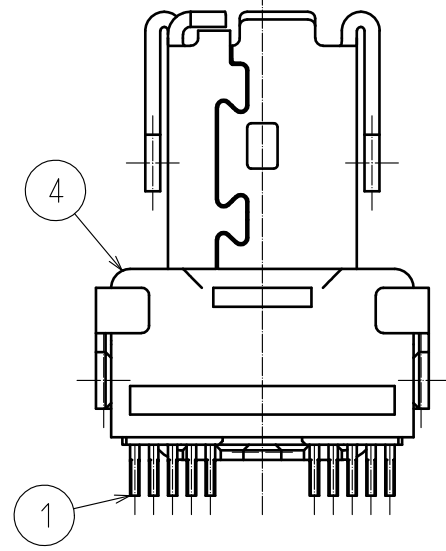

3	Stainless Steel		7	PE	
2	LCP	Gray - UL94V-0	6	PS	
1	Copper Alloy	Contact area : Gold 0.2 μm min. Lead area : Gold 0.03 μm min. Under plating : Nickel 2 μm min.	5	Stainless Steel	Tin 1 μm min.
			4	LCP	Gray - UL94V-0
NO.	MATERIAL	FINISH . REMARKS	NO.	MATERIAL	FINISH . REMARKS
UNITS	mm	SCALE	5 : 1	COUNT	7
		DESCRIPTION OF REVISIONS	DESIGNED	CHECKED	DATE
		DIS-E-00001118	JY. IGA	KI. NAGANUMA	17. 08. 07
APPROVED : RI. TAKAYASU		17. 03. 28	DRAWING NO. EDC-129430-00-00		
CHECKED : KI. NAGANUMA		17. 03. 27	PART NO. IX61G-A-10P		
DESIGNED : TS. SAKAIZAWA		17. 03. 27	CODE NO. CL251-0021-0-00		
DRAWN : TS. SAKAIZAWA		17. 03. 27	1/3		

Reference PCB Layout (Connector Mounting Side) (t = 1.6)

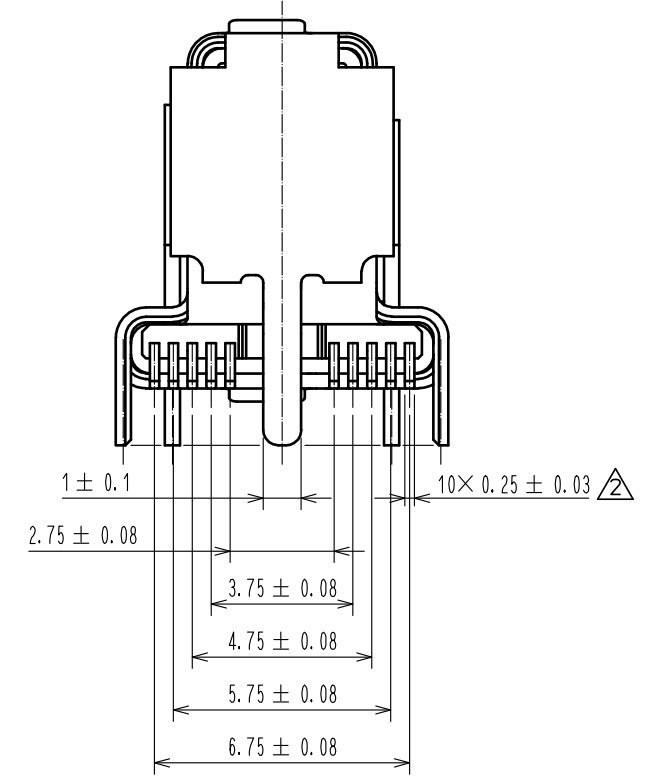
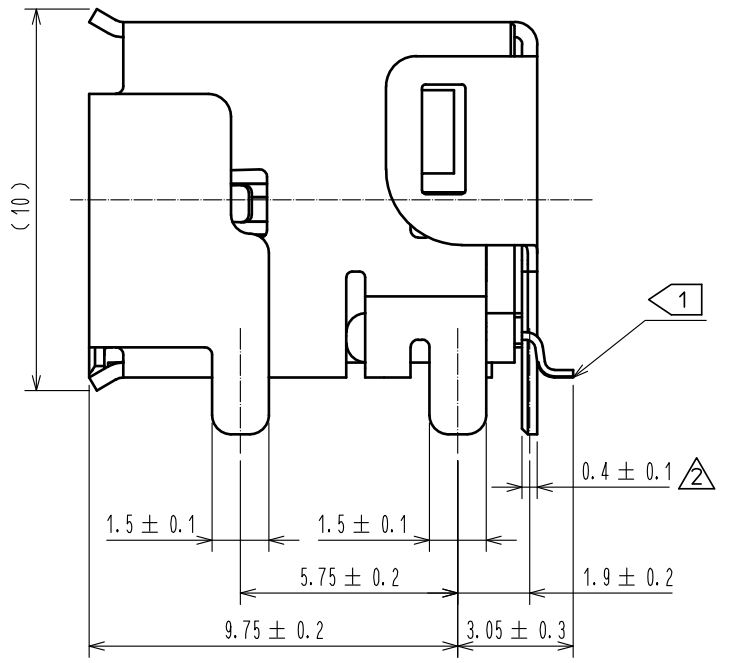
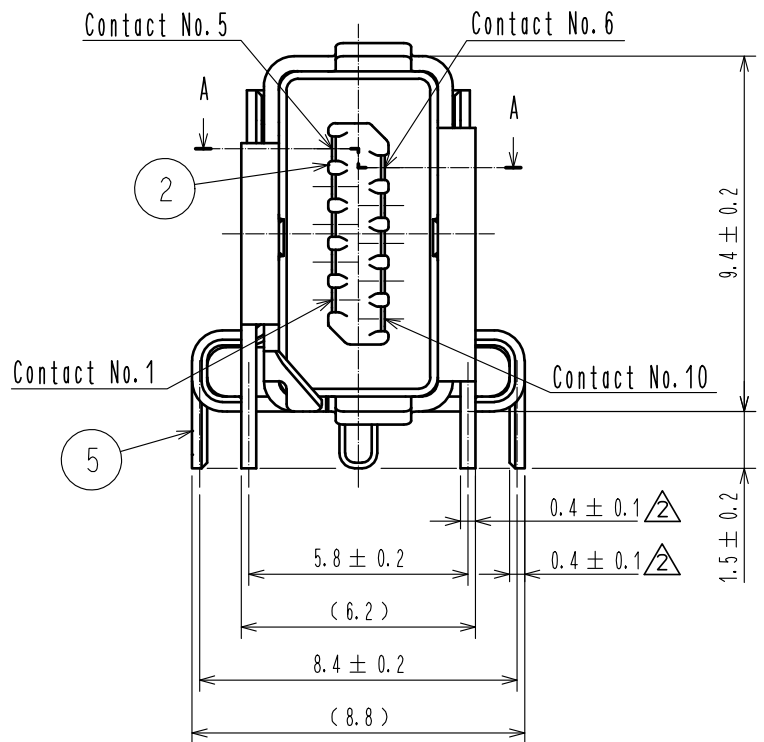
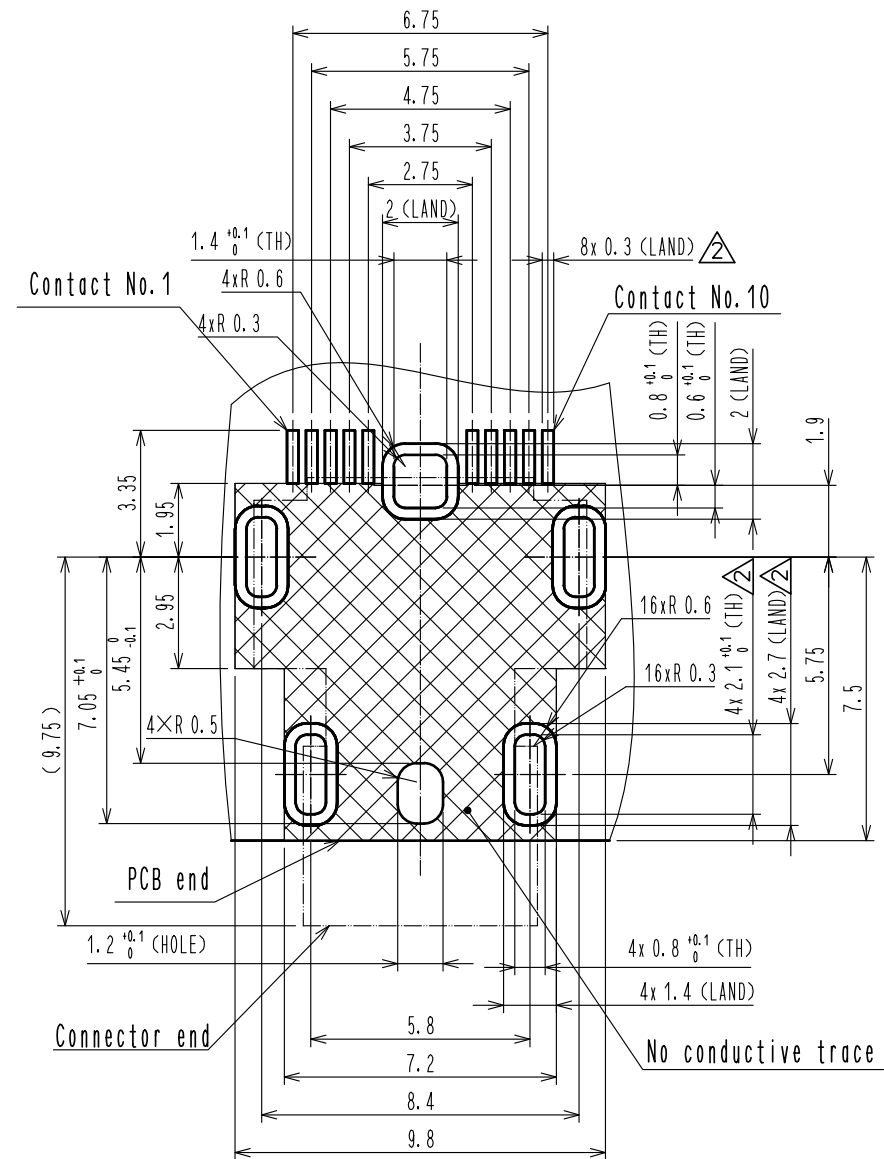

General tolerance is +/- 0.05

Reference Metal Mask Layout (t = 0.15)

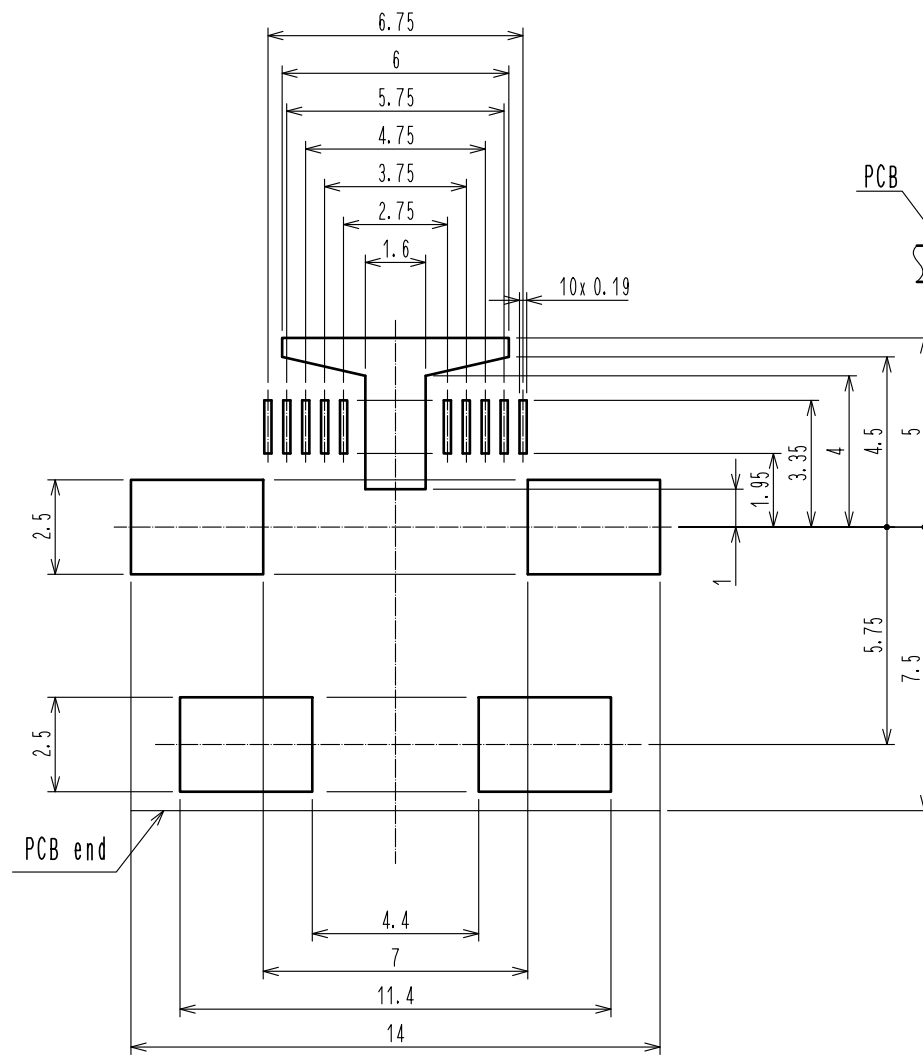

General tolerance is +/- 0.02

Mated Condition (Free)

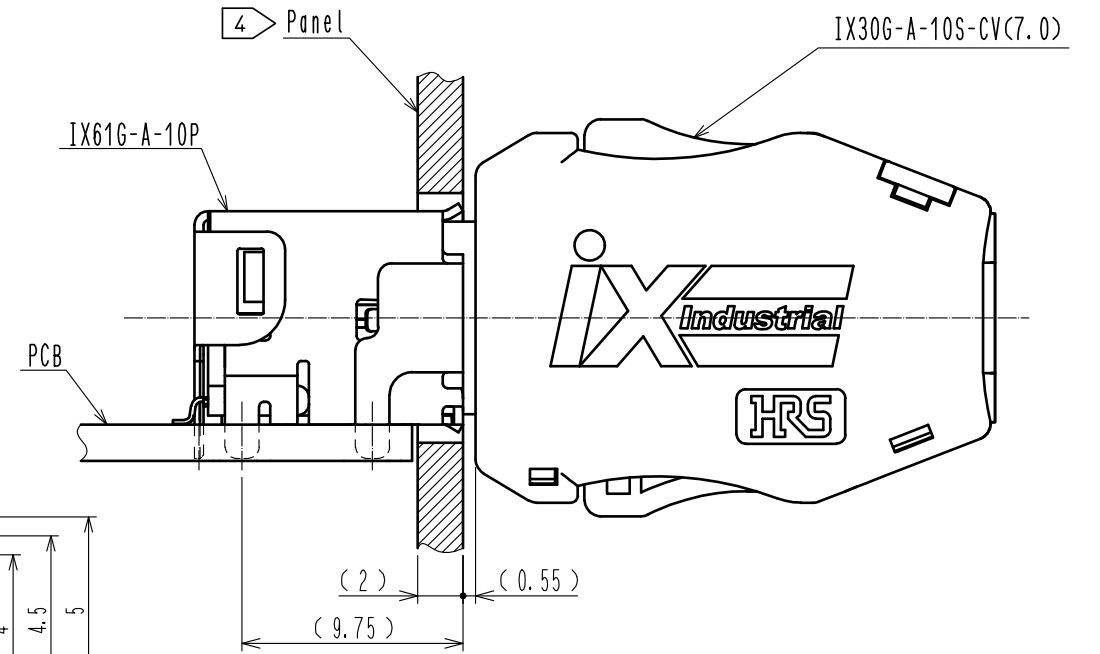

Reference Dimensions of Panel Cutout (Free)

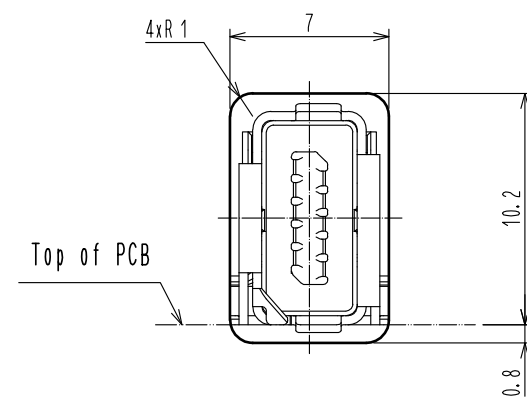

Dimension is reference.

Thickness of metal mask is 0.1 mm min.

Metal mask dimensions of the drawings described, are reference dimensions for 0.15 mm thickness metal mask.

Change the metal mask dimensions by thickness of the metal mask, thickness of PCB, component of solder paste and mounting conditions.

Change the metal mask dimensions in case of mounting IX61G-+-10P in parallel.

Change the metal mask dimensions, if there are other mounting parts or implementation pattern around the portion of mounting position of IX61G-+-10P.

Refer to the technical specification (ETAD-E3170-00) for different variations of the metal mask pattern width.

HRS	DRAWING NO.	EDC-129430-00-00
	PART NO.	IX61G-A-10P
	CODE NO.	CL251-0021-0-00

3 Drawing for packing (Free)

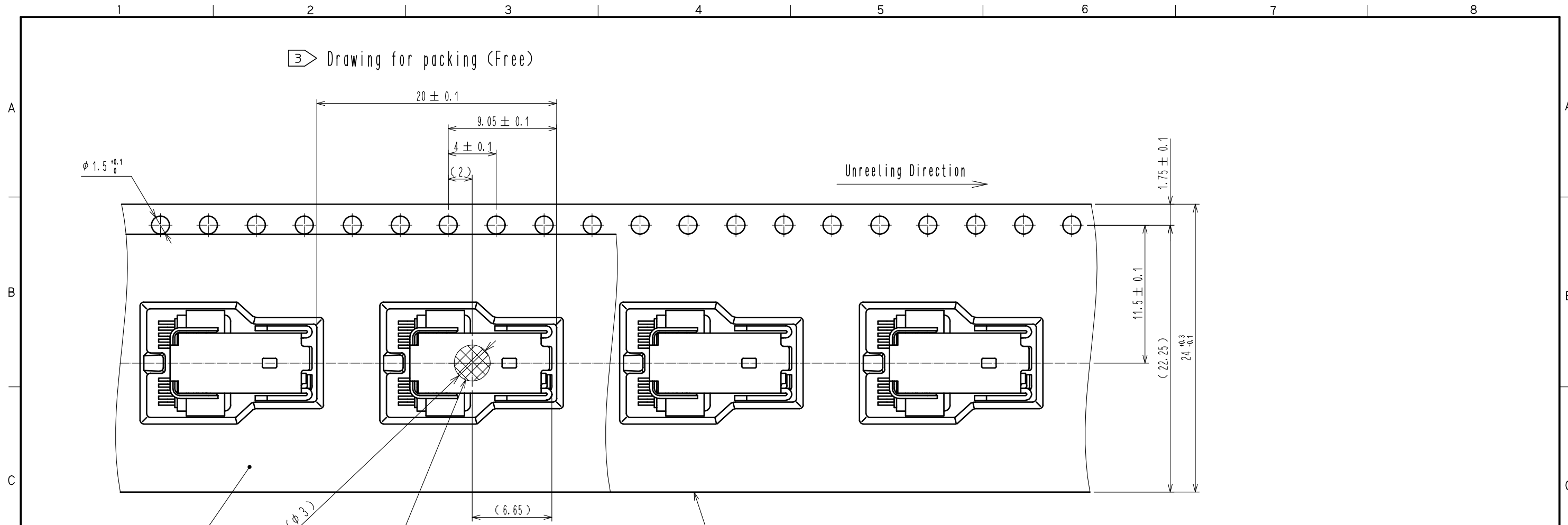

7

Picking Area

6

Notes. 7. This product (Type A) is defined for 10/100 Mbit/s and 1/10 Gbit/s Ethernet communication. Please use Type B for all other non Ethernet applications like signaling, serial or other industrial bus communication systems.

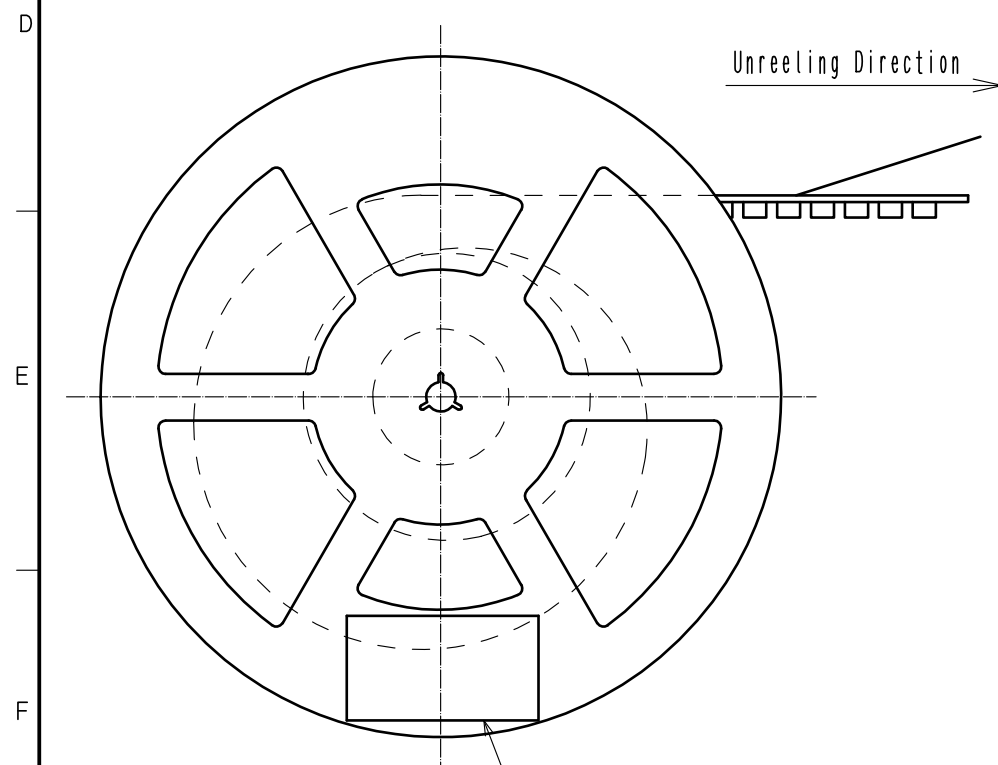

Label (Part No., Code No., Lot nO., Packing Quantity)

Mating Shape

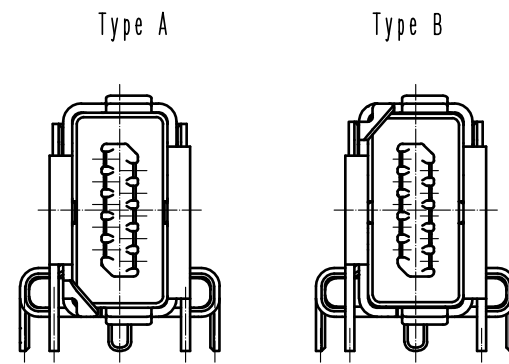

Pin Assignment For 10/100 Mbit/s And 1/10 Gbit/s Ethernet

Contact No.	Signal	
	10/100 Mbit/s	1/10 Gbit/s
1	TX+	BI_DA+
2	TX-	BI_DA-
3	N. C	GND
4	N. C	BI_DC+
5	N. C	BI_DC-
6	RX+	BI_DB+
7	RX-	BI_DB-
8	N. C	GND
9	N. C	BI_DD+
10	N. C	BI_DD-

HRS

DRAWING NO.	EDC-129430-00-00
PART NO.	IX61G-A-10P
CODE NO.	CL251-0021-0-00

2/3