

| REVISIONS | | | | | |
|-----------|-----|-----------------------|---------|-----|------|
| P. | LTM | DESCRIPTION | DATE | DMN | APVD |
| F | | REV PER ECO 17-005921 | 6-16-17 | CT | DM |
| | | | | | |
| | | | | | |

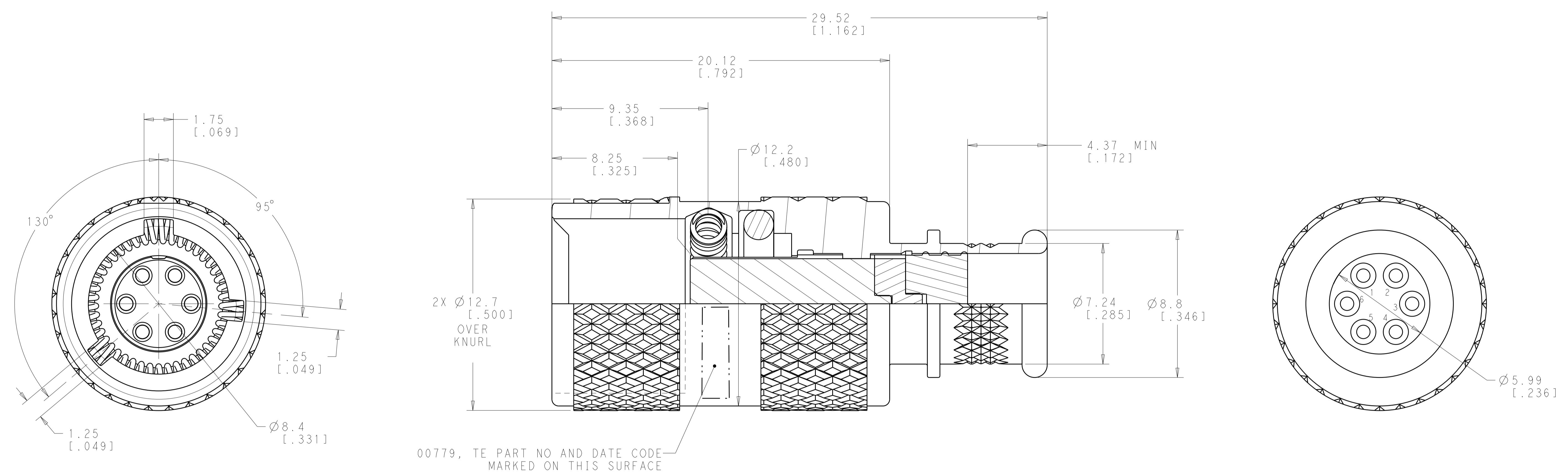

- TE MATING CONNECTOR PART NUMBER 2226910-1.
- SHELL FINISH: SELECTIVE PLATE 12.7µm MIN ZINC-NICKEL OVER 12.7µm MIN ELECTROLESS NICKEL ALL OVER.
- ROHS COMPLIANT.
- MATERIALS: ALUMINUM ALLOY, THERMOPLASTIC AND FLUORSILICONE .
- CONNECTOR SHALL MEET ENVIRONMENTAL REQUIREMENTS PER MIL-STD-810G.
- ASSEMBLY ACCEPTS SIZE 23 SOCKET CONTACTS.
- CONTACT CURRENT RATING 5 AMPS CRIMPED TO 22AWG WIRES.
- CONNECTOR SHIPPED WITH DUST CAPS.
- CONNECTOR WEIGHT: 4.39 grams (W/O CONTACTS).
- MARKINGS PER MIL-STD-202, METHOD 215.
- CONTACTS (8) ARE KITTED IN SEALED PLASTIC BAG AND SHIPPED UN-ASSEMBLED TO CONNECTOR.
- UNLESS OTHERWISE SPECIFIED, ALL DIMENSIONS ARE FOR REFERENCE ONLY.
- THIS DRAWING HAS UNLIMITED USAGE RIGHTS.

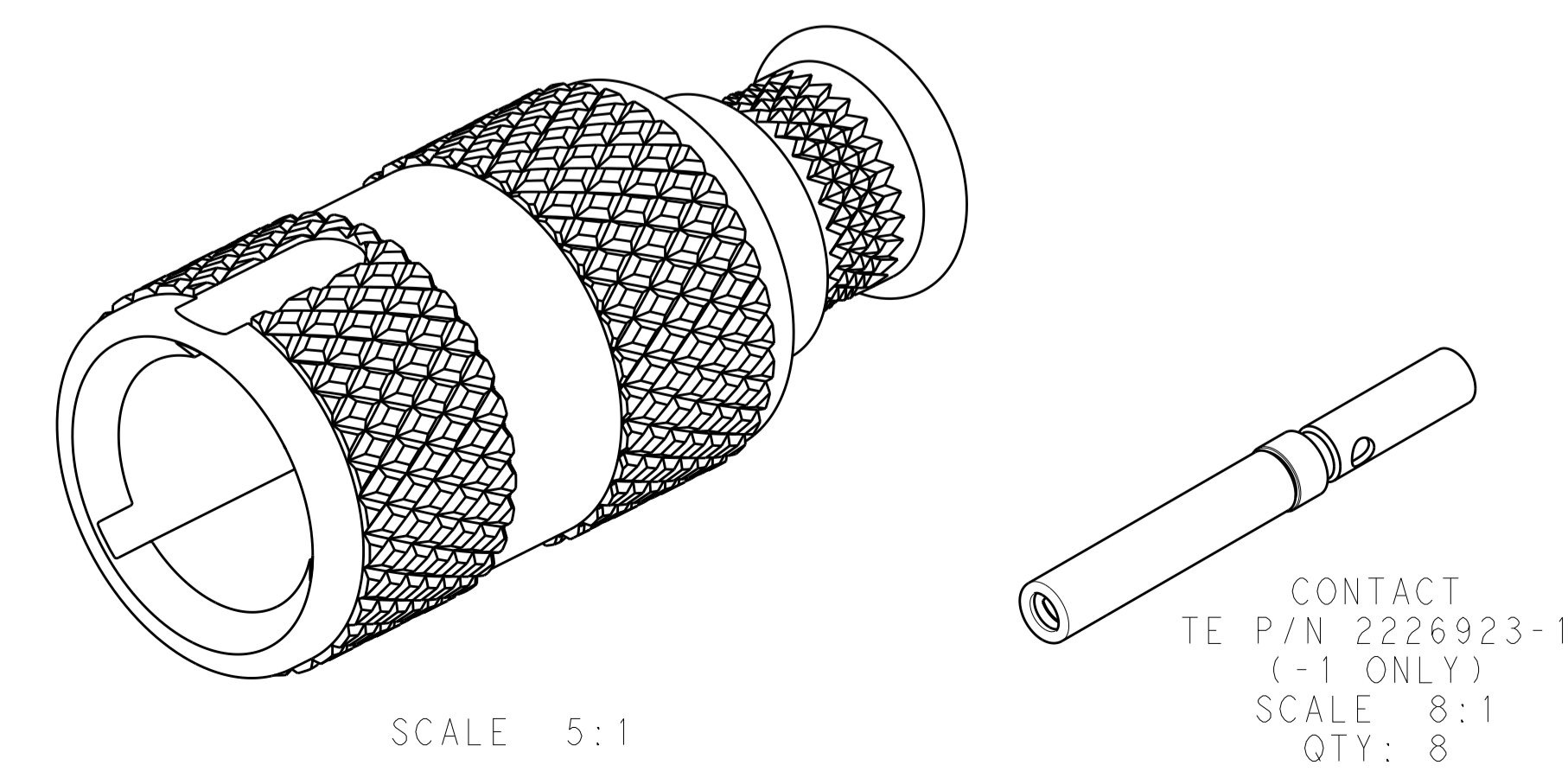

SCALE 5:1

CONTACT
 TE P/N 2226923-1
 (-1 ONLY)
 SCALE 8:1
 QTY: 8

| | |
|---------|-----------|
| --- | 2226920-2 |
| 11 | 2226920-1 |
| REMARKS | PART NO |

| | | | | | | | |
|--|--|------------------|-----------|---------------|--|-------------------------------|--|
| THIS DRAWING IS A CONTROLLED DOCUMENT. | | DMN | 03FEB2014 | NAME | | RECEPTACLE CONNECTOR ASSEMBLY | |
| DIMENSIONS: | | CHK | 07FEB2014 | SIZE | | A1 | |
| mm [INCHES] | | C.YI | 07FEB2014 | CAGE CODE | | - | |
| TOLERANCES UNLESS OTHERWISE SPECIFIED: | | APVD | 07FEB2014 | DRAWING NO | | C=2226920 | |
| 0 PLC ± | | PRODUCT SPEC | | RESTRICTED TO | | - | |
| 1 PLC ± | | APPLICATION SPEC | | SCALE | | 8:1 | |
| 2 PLC ±0.131(.005) | | WEIGHT | | SHEET | | 1 OF 1 | |
| 3 PLC ± | | CUSTOMER DRAWING | | REV | | F | |
| 4 PLC ± | | | | | | | |
| ANGLES ± | | | | | | | |
| FINISH | | | | | | | |