

Feb.1.2018 Copyright 2018 HIROSE ELECTRIC CO., LTD. All Rights Reserved.

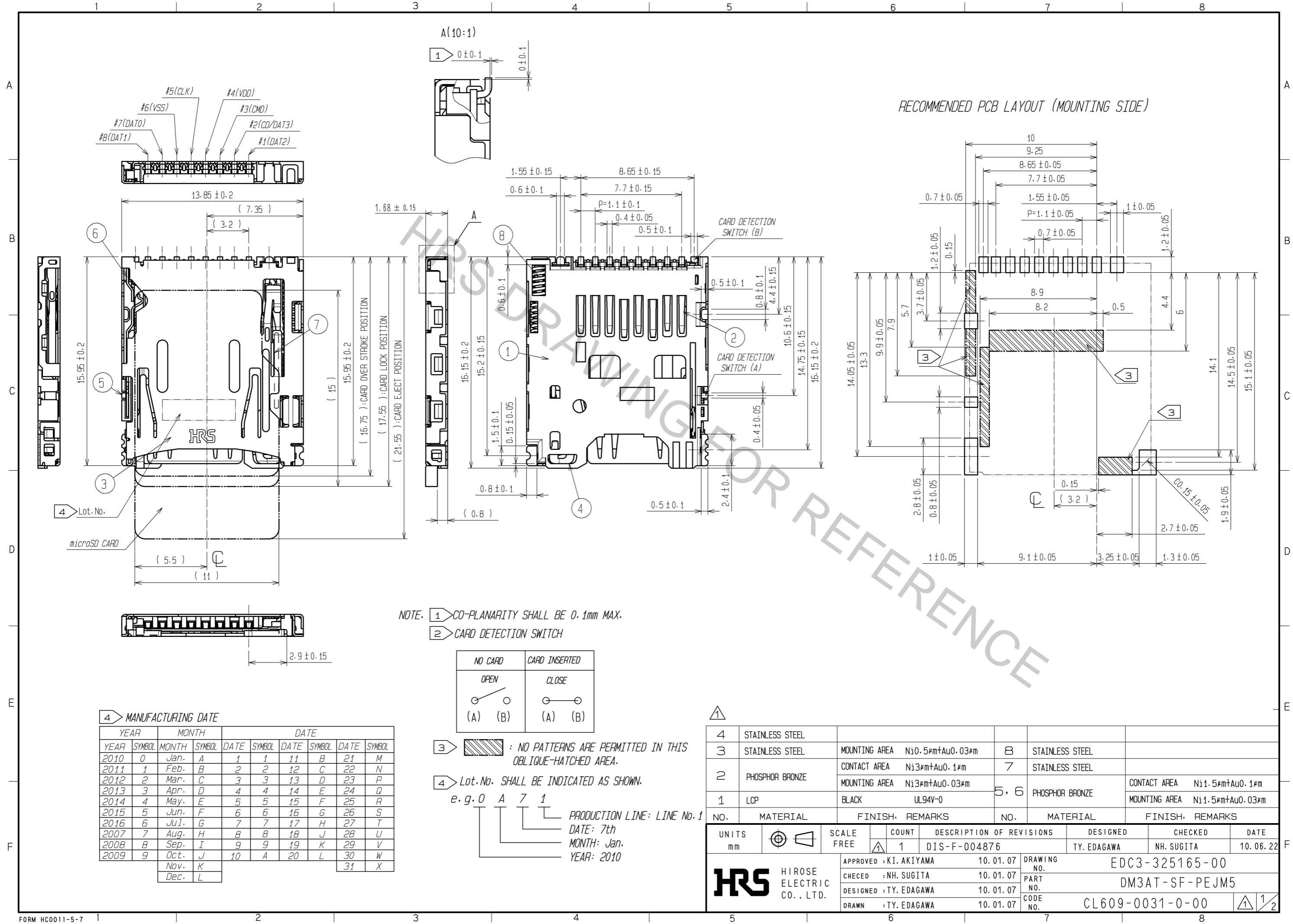

NOTE. 1 CO-PLANARITY SHALL BE 0.1mm MAX.
 2 CARD DETECTION SWITCH

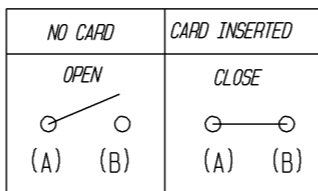

3 : NO PATTERNS ARE PERMITTED IN THIS OBLIQUE-HATCHED AREA.

4 Lot.No. SHALL BE INDICATED AS SHOWN.
 e.g. 0 A 7 1
 PRODUCTION LINE: LINE No. 1
 DATE: 7th
 MONTH: Jan.
 YEAR: 2010

4 MANUFACTURING DATE

YEAR	MONTH	DATE							
YEAR	SYMBOL	MONTH	SYMBOL	DATE	SYMBOL	DATE	SYMBOL	DATE	SYMBOL
2010	0	Jan.	A	1	1	11	B	21	M
2011	1	Feb.	B	2	2	12	C	22	N
2012	2	Mar.	C	3	3	13	D	23	P
2013	3	Apr.	D	4	4	14	E	24	Q
2014	4	May.	E	5	5	15	F	25	R
2015	5	Jun.	F	6	6	16	G	26	S
2016	6	Jul.	G	7	7	17	H	27	T
2007	7	Aug.	H	8	8	18	J	28	U
2008	8	Sep.	I	9	9	19	K	29	V
2009	9	Oct.	J	10	A	20	L	30	W
		Nov.	K					31	X
		Dec.	L						

NO.	MATERIAL	FINISH	REMARKS	NO.	MATERIAL	FINISH	REMARKS
4	STAINLESS STEEL						
3	STAINLESS STEEL		MOUNTING AREA Ni0.5μm+Au0.03μm	8	STAINLESS STEEL		
2	PHOSPHOR BRONZE		CONTACT AREA Ni3μm+Au0.1μm	7	STAINLESS STEEL		
1	LCP	BLACK	UL94V-0	5, 6	PHOSPHOR BRONZE		CONTACT AREA Ni1.5μm+Au0.1μm
							MOUNTING AREA Ni1.5μm+Au0.03μm

UNITS	SCALE	COUNT	DESCRIPTION OF REVISIONS	DESIGNED	CHECKED	DATE
mm	FREE	1	DIS-F-004876	TY. EDAGAWA	NH. SUGITA	10.06.22

APPROVED	DATE	DRAWING NO.
KI. AKIYAMA	10.01.07	EDC3-325165-00
NH. SUGITA	10.01.07	PART NO. DM3AT-SF-PEJM5
TY. EDAGAWA	10.01.07	CODE NO. CL609-0031-0-00
TY. EDAGAWA	10.01.07	

Feb.1.2018 Copyright 2018 HIROSE ELECTRIC CO., LTD. All Rights Reserved.

5 DRAWING FOR PACKING

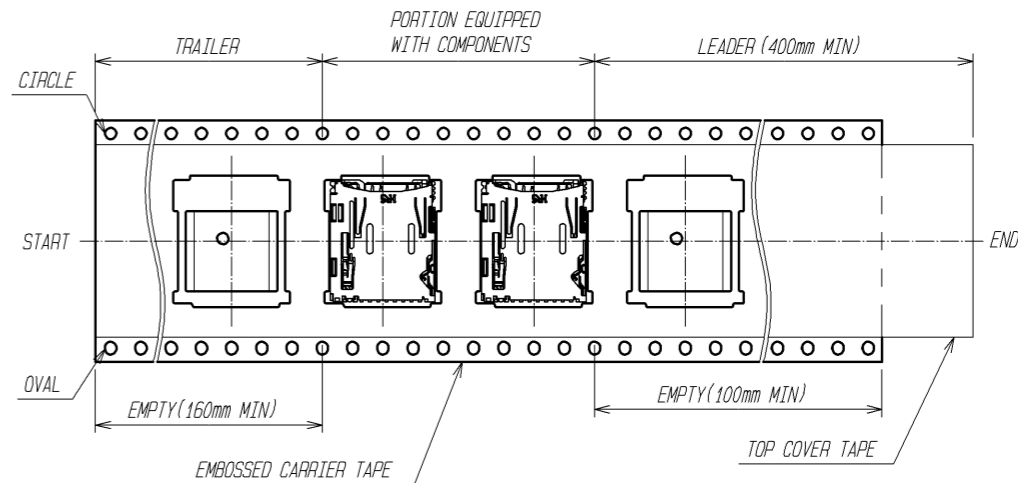
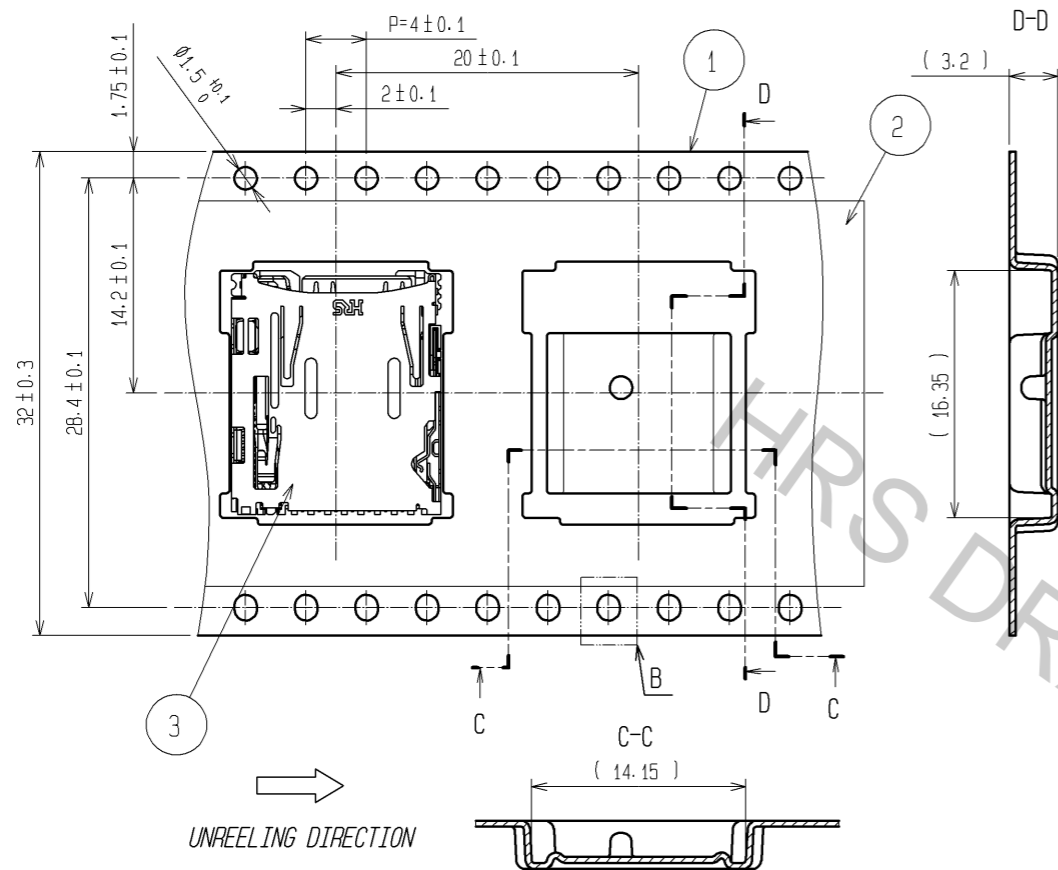

DETAIL OF REEL (1:10)

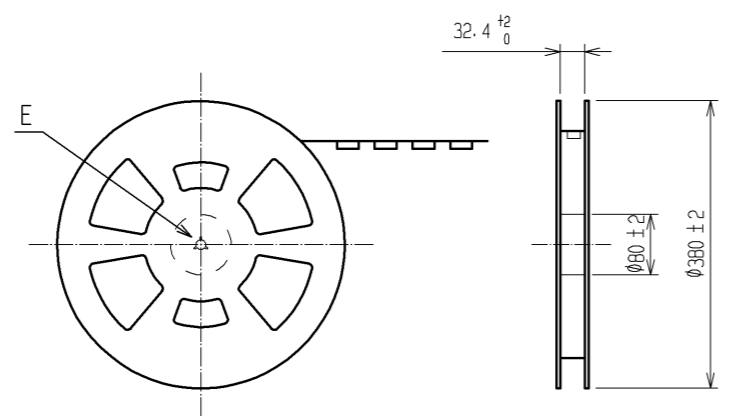

B(10:1)

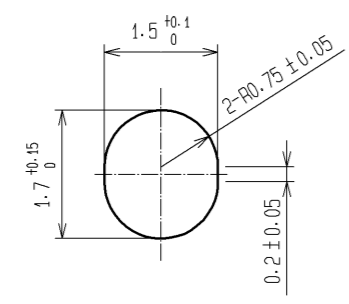

E(1:1)

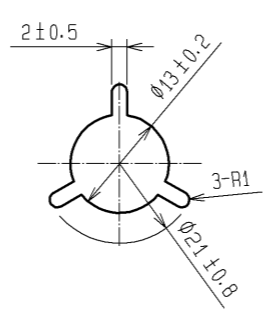

NOTE. 5 PACKING TYPE: TAPE AND REEL. 1500PCS PER REEL.
 6 PLEASE REFER TO TECHNICAL SPECIFICATION : ETAD-F0345
 DM3AT SERIES PRODUCT INFORMATION AND HANDLING INSTRUCTIONS
 FOR THE HANDLING OF THE PRODUCT.

3	(CONNECTORS)	
2	POLYESTER	
1	PS	
NO.	MATERIAL	FINISH, REMARKS

UNITS mm		SCALE 2 : 1	COUNT 1	DESCRIPTION OF REVISIONS DIS-F-004876	DESIGNED TY. EDAGAWA	CHECKED NH. SUGITA	DATE 10.06.22
HRS HIROSE ELECTRIC CO., LTD.		APPROVED : KI. AKIYAMA	10.01.07	DRAWING NO.	EDC3-325165-00		
		CHECED : NH. SUGITA	10.01.07	PART NO.	DM3AT-SF-PEJM5		
		DESIGNED : TY. EDAGAWA	10.01.07	CODE NO.	CL609-0031-0-00		
		DRAWN : TY. EDAGAWA	10.01.07		1/2		