

Customer Information Sheet

DRAWING No.: M50-360XX42R

SHEET 3 OF 4

IF IN DOUBT - ASK

©

NOT TO SCALE

THIRD ANGLE PROJECTION

ALL DIMENSIONS IN mm

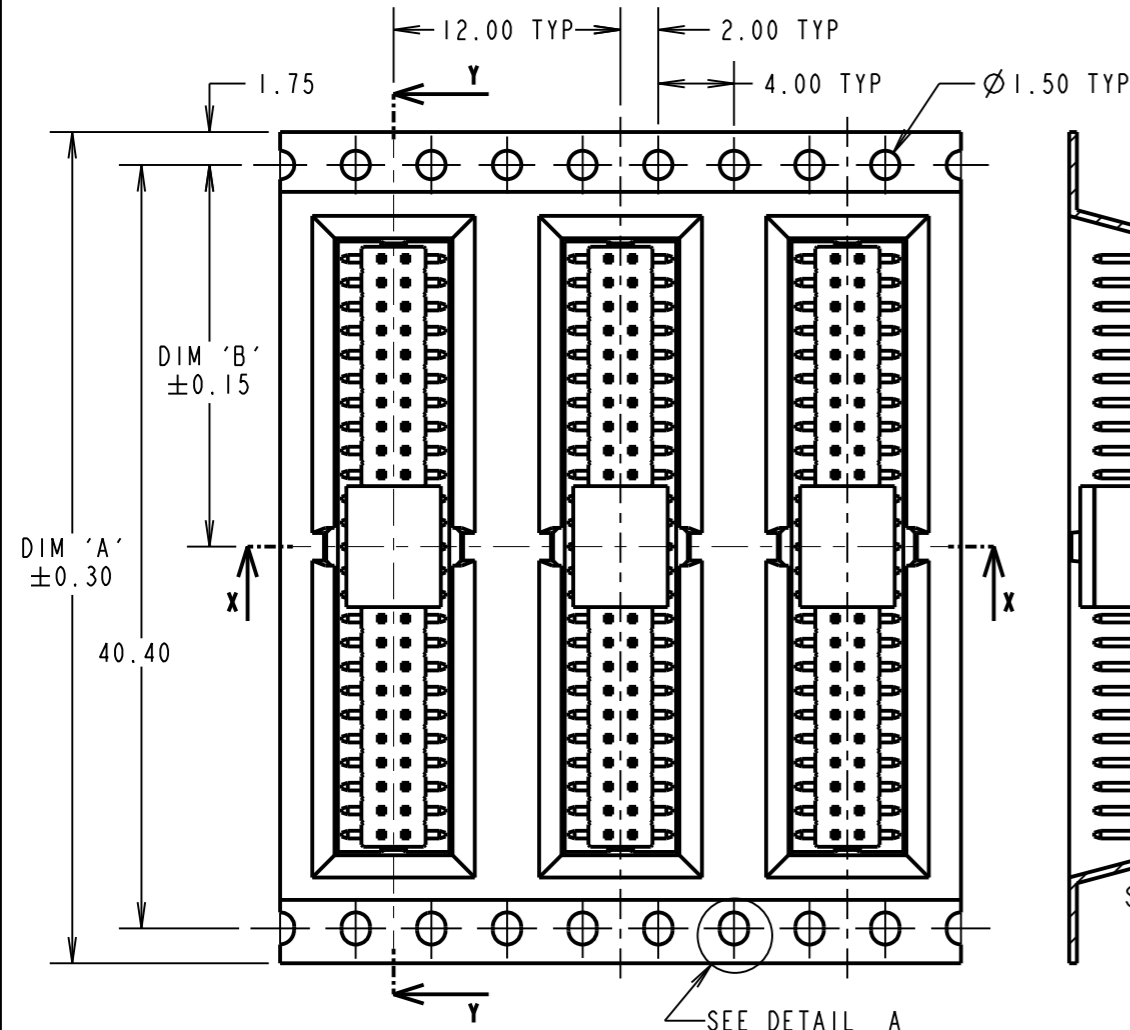

TAPE DETAILS FOR 20 & 25 WAYS

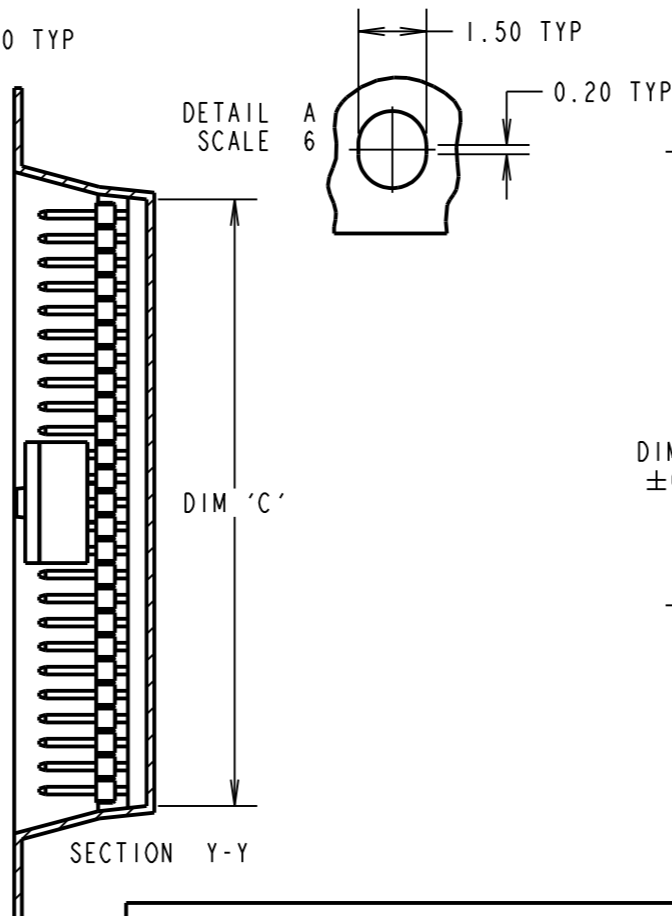
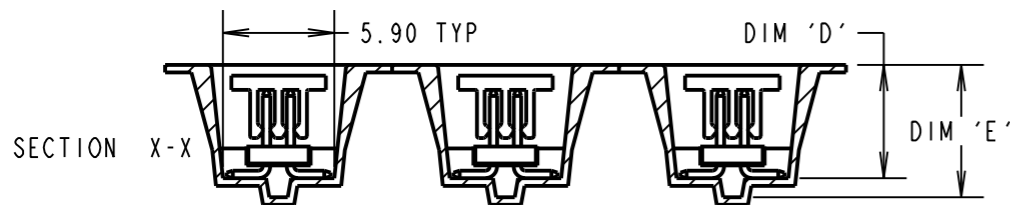

TAPE DETAILS FOR 02, 03, 04, 05, 06 & 10 WAYS

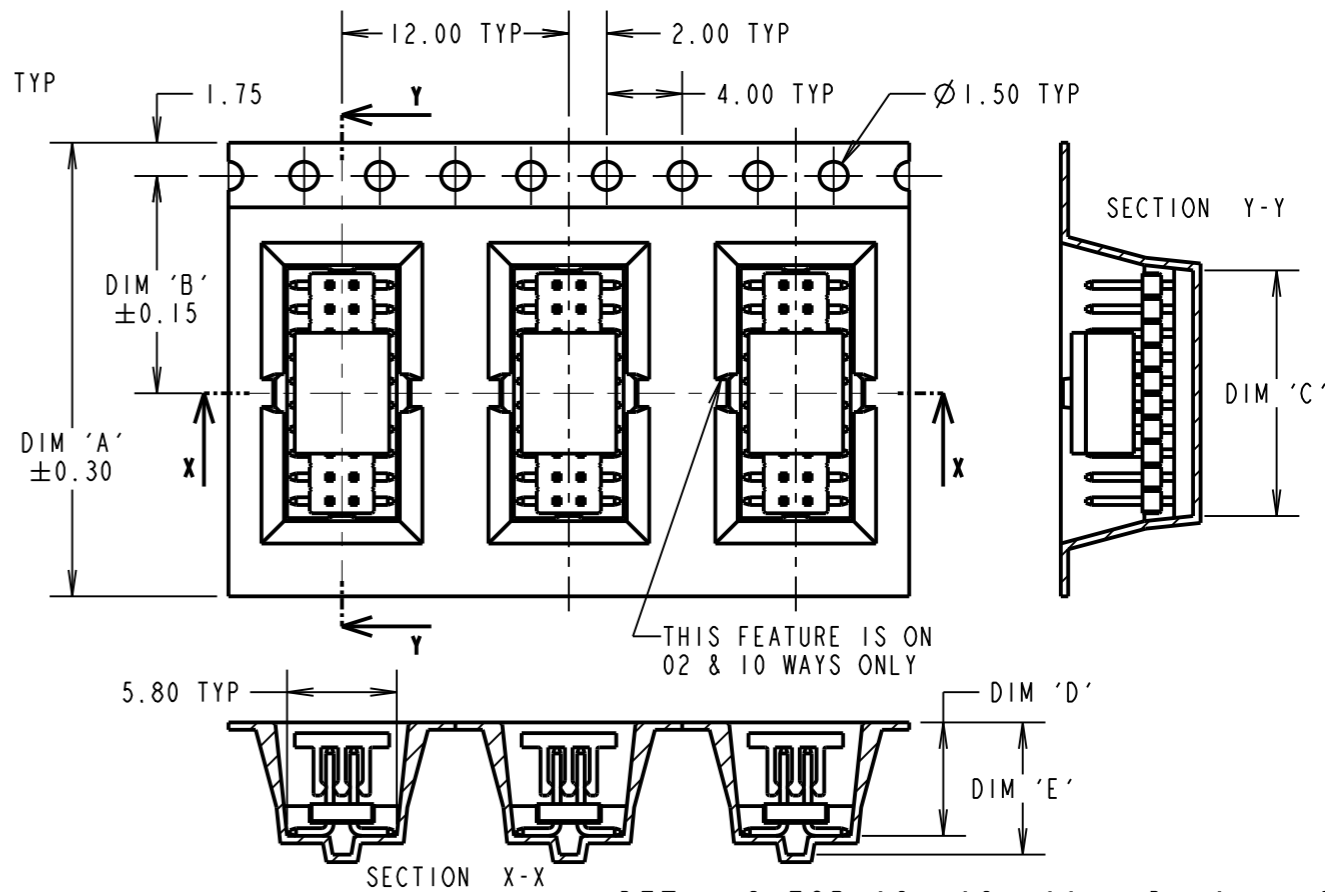

DETAILS FOR 02, 03, 06 AND 10 WAYS

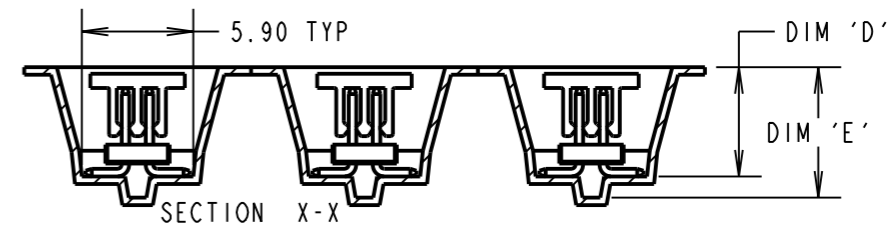

DETAILS FOR 04 AND 05 WAYS

ORDER CODE:

M50-360XX42R

No. OF CONTACTS PER ROW:
02, 03, 04, 05, 06, 10, 20, 25

FINISH:
42 = SELECTIVE GOLD & 100% TIN OVER NICKEL

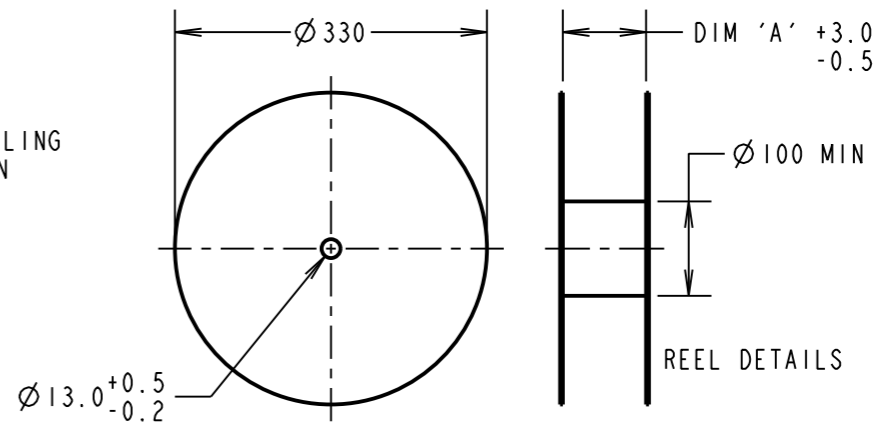
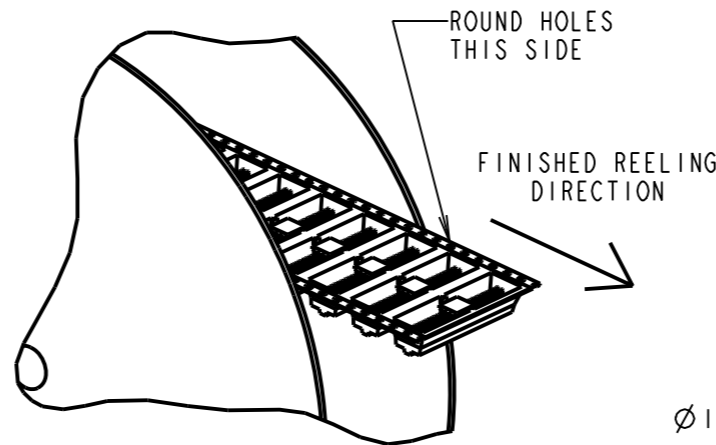

REELED PART No.	DIM 'A'	DIM 'B'	DIM 'C'	DIM 'D'	DIM 'E'	REEL QTY
M50-3600242R	16.00	7.50	3.60	6.00	7.20	750
M50-3600342R			4.00		7.00	
M50-3600442R	24.00	11.50	5.40	5.78	6.90	800
M50-3600542R			6.65			
M50-3600642R			7.90			
M50-3601042R	44.00	20.20	13.00	6.00	7.00	750
M50-3602042R			25.70			
M50-3602542R			32.10			

- NOTES:
- CUMULATIVE TOLERANCES OVER 10 PITCHES = ±0.20mm
 - TAPE & REELING TO BE IN ACCORDANCE WITH EIA-481 (ELECTRONIC INDUSTRIES ASSOCIATION).
 - FOR CONNECTOR DETAILS SEE SHEET 4.

HARWIN

www.harwin.com
technical@harwin.com

THIS DRAWING AND ANY INFORMATION OR DESCRIPTIVE MATTER SET OUT HEREON ARE CONFIDENTIAL AND COPYRIGHT PROPERTY OF THE HARWIN GROUP AND MUST NOT BE DISCLOSED, LOANED, COPIED OR USED FOR MANUFACTURING, TENDERING OR FOR ANY OTHER PURPOSE WITHOUT THEIR WRITTEN PERMISSION.

TOLERANCES
X. = ±1mm
X.X = ±0.25mm
X.XX = ±0.10mm
X.XXX = ±0.01mm
ANGLES = ±5°
UNLESS STATED

MATERIAL:
SEE ABOVE
FINISH: SEE ABOVE
S/AREA: mm²

TITLE: 1.27mm PITCH DIL SMT VERT
LOW PROFILE SOCKET ASSY
(TAPE & REEL)

DRAWING NUMBER:
M50-360XX42R

SB	11	10.12.13	12302
NAME	ISS.	DATE	C/NOTE
APPROVED:		S. BENNETT	
CHECKED:		S. FLOWER	
DRAWN:		R. ADDE	
CUSTOMER REF.:			
ASSEMBLY DRG.:			

Customer Information Sheet

DRAWING No.: M50-360XX42R

SHEET 4 OF 4

IF IN DOUBT - ASK

©

NOT TO SCALE

THIRD ANGLE PROJECTION

ALL DIMENSIONS IN mm

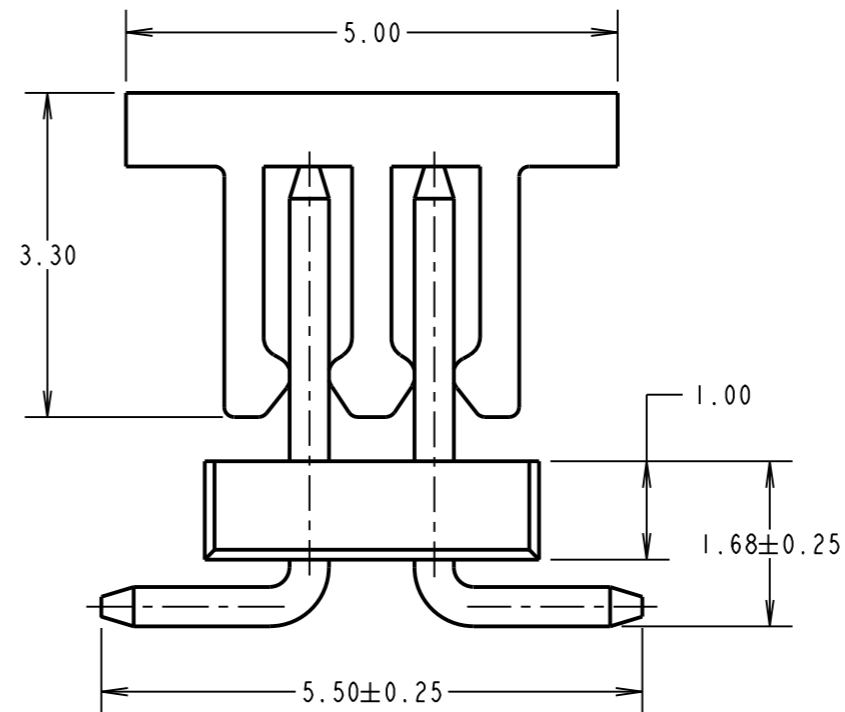
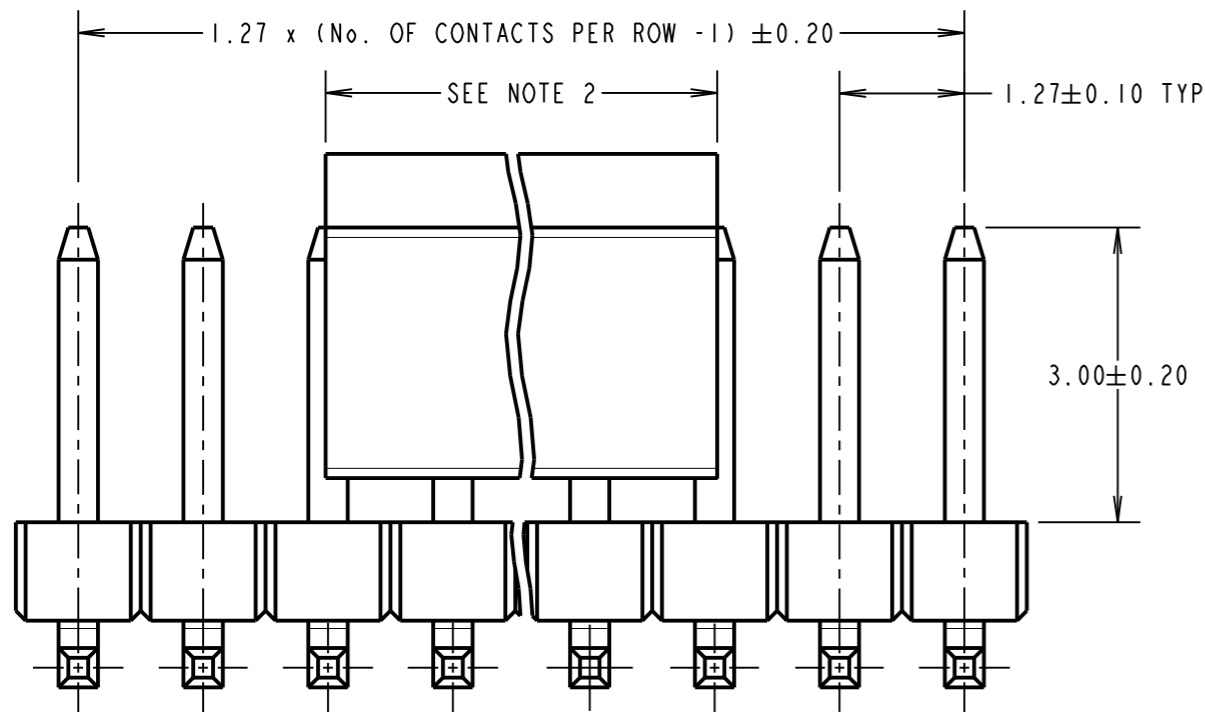
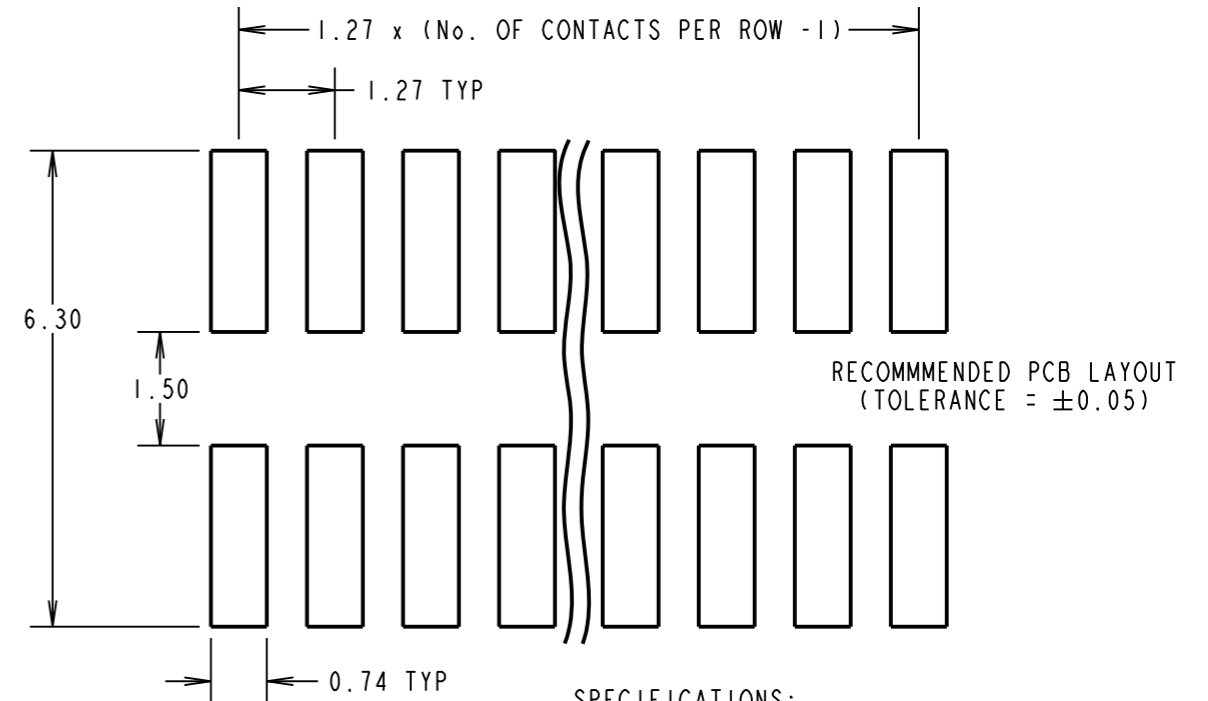
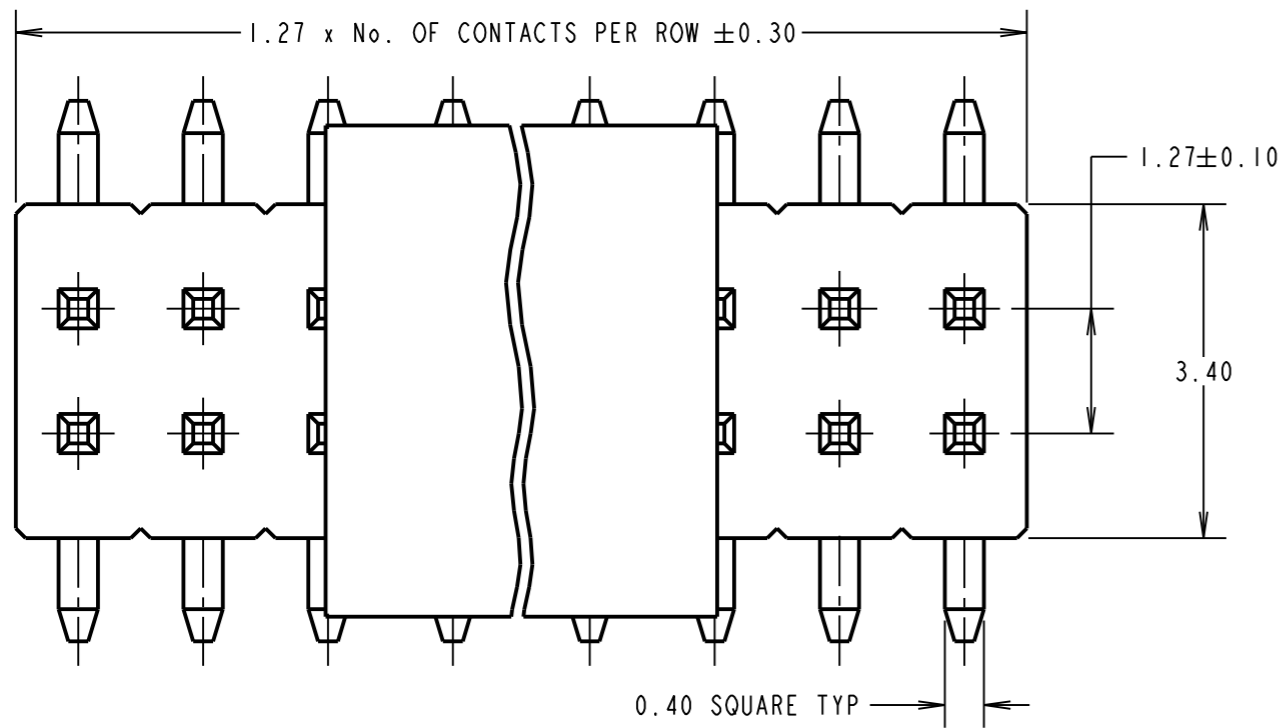

SPECIFICATIONS:

MATERIAL:
 MOULDING = HIGH TEMP THERMOPLASTIC,
 UL94V-0, BLACK
CONTACTS = COPPER ALLOY
FINISH:
 CONTACTS = 0.70 TO 1.30 μ NICKEL ALL OVER,
 0.08 TO 0.15 μ GOLD ON CONTACT AREA,
 2.50 TO 3.00 μ 100% TIN ON TAILS

ELECTRICAL:
 CURRENT RATING = 1A
 CONTACT RESISTANCE = 20m Ω MAX
 INSULATION RESISTANCE = 1000M Ω MIN
 DIELECTRIC WITHSTANDING = 1000V AC FOR
 ONE MINUTE

MECHANICAL:
 DURABILITY = 300 CYCLES MIN
ENVIRONMENTAL:
 TEMPERATURE RANGE = -40°C TO +105°C

PACKING:
 BOX
 FOR COMPLETE SPECIFICATION, SEE COMPONENT
 SPECIFICATION C029XX (LATEST ISSUE)

NOTES:

- CO-PLANARITY OF TAILS FOR 02 TO 30 CONTACTS PER ROW = 0.15mm,
 31 TO 50 CONTACTS PER ROW = 0.20mm.
- PICK AND PLACE CAP LENGTH = 3.60mm FOR 02 TO 05 CONTACTS PER ROW,
 6.40mm FOR 06 TO 50 CONTACTS PER ROW.
- ALL TOLERANCES ARE ± 0.15 , UNLESS OTHERWISE STATED.
- FOR TAPE AND REEL DETAILS, SEE SHEET 3.

ORDER CODE:

M50-360XX42R

No. OF CONTACTS PER ROW: _____
 02, 03, 04, 05, 06, 10, 20, 25

FINISH: _____
 42 = SELECTIVE GOLD & 100% TIN OVER NICKEL

SB	11	10.12.13	12302
NAME	ISS.	DATE	C/NOTE
APPROVED:		S.BENNETT	
CHECKED:		S.FLOWER	
DRAWN:		R.ADDE	
CUSTOMER REF.:			
ASSEMBLY DRG.:			

HARWIN

www.harwin.com
 technical@harwin.com

THIS DRAWING AND ANY
 INFORMATION OR DESCRIPTIVE
 MATTER SET OUT HEREON ARE
 CONFIDENTIAL AND COPYRIGHT
 PROPERTY OF THE HARWIN
 GROUP AND MUST NOT BE
 DISCLOSED, LOANED, COPIED
 OR USED FOR MANUFACTURING,
 TENDERING OR FOR ANY
 OTHER PURPOSE WITHOUT
 THEIR WRITTEN PERMISSION.

TOLERANCES
 X = ± 1 mm
 X.X = ± 0.25 mm
 X.XX = ± 0.10 mm
 X.XXX = ± 0.01 mm
 ANGLES = $\pm 5^\circ$
 UNLESS STATED

MATERIAL:

SEE ABOVE

FINISH: SEE ABOVE

S/AREA:

mm²

TITLE: 1.27mm PITCH DIL SMT VERT
 LOW PROFILE SOCKET ASSY
 (TAPE & REEL)

DRAWING NUMBER:

M50-360XX42R

SHT
 4 OF 4