

DESCRIPTION: FEMALE - 0.370 RIGHT ANGLE / MACHINED - ECONOMY

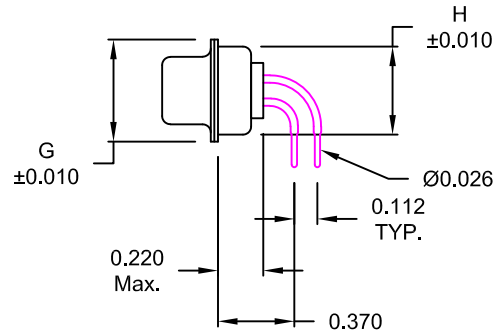
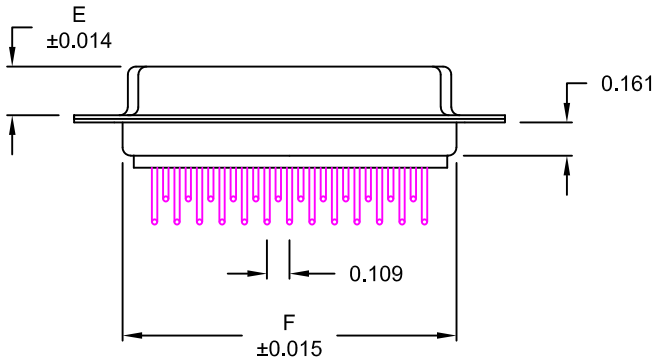
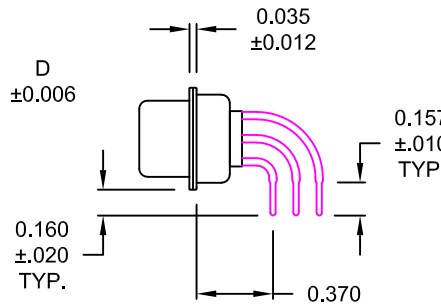
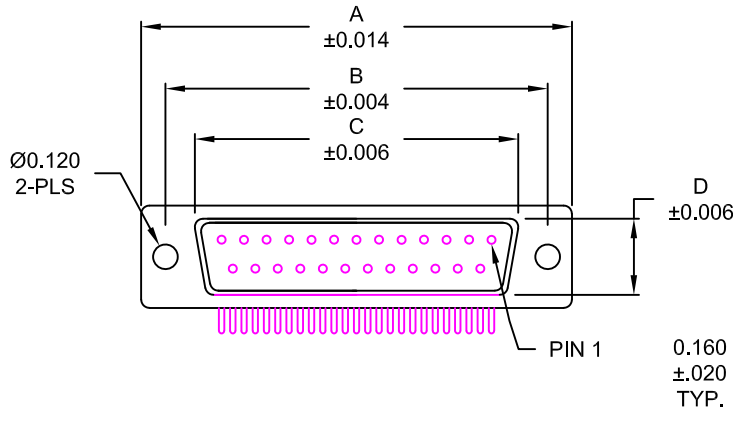

No. OF PINS	DIMENSIONS							
	A	B	C	D	E	F	G	H
9	1.213	0.984	0.642	0.311	0.236	0.756	0.496	0.427
	30.80	24.99	16.30	7.90	5.99	19.20	12.60	10.85
15	1.541	1.312	0.970	0.311	0.236	1.091	0.496	0.427
	39.15	33.32	24.65	7.90	5.99	27.70	12.60	10.85
25	2.087	1.852	1.512	0.311	0.236	1.618	0.496	0.427
	53.00	47.04	38.40	7.90	5.99	41.10	12.60	10.85
37	2.728	2.500	2.157	0.311	0.236	2.256	0.496	0.427
	69.30	63.50	54.80	7.90	5.99	57.30	12.60	10.85
50	2.638	2.406	2.055	0.429	0.240	2.169	0.602	0.527
	67.00	61.11	52.20	10.90	6.10	55.10	15.30	13.39

174-EYY-21YRYY1

- SERIES _____
- POSITIONS _____
- E09 _____
- E15 _____
- E25 _____
- E37 _____
- E50 _____
- GENDER _____
- 2 = FEMALE
- TERMINATION _____
- 1 = PC MOUNTING
- SHELL PLATING _____
- 3 = NICKEL
- RoHS COMPLIANT _____
- HARDWARE OPTIONS _____
- 00 = NO HARDWARE
- 01 = 0.098" CLINCH NUT (BOARD SIDE)
- 14 = SHORT BRACKET WITH 4-40 SCREW LOCK
- 24 = SHORT BRACKET WITH 4-40 SCREW
- 46 = BRACKET WITH 4-40 INSERT AND BOARDLOCK
- PLATING OPTIONS _____
- 1 = GOLD FLASH
- 2 = 30MICRO-INCH GOLD
- 3 = 50MICRO-INCH GOLD

MATERIAL:

SHELL: STEEL, NICKEL PLATED
 INSULATOR: UL 94V-O RATED, WHITE PA6T
 PROCESS TEMP.: 260° PROCESS TEMPERATURE
 CONTACT: BRASS

ELECTRICAL:

CURRENT RATING: 5 AMPS
 CONTACT RESISTANCE: 15 mOhms Max.
 INSULATION RESISTANCE: 1,000 MOhms min.
 VOLTAGE: 500VAC FOR 1 MINUTE
 TEMPERATURE: -50° C TO 100° C

DO NOT SCALE FROM DRAWING



THESE DRAWINGS AND SPECIFICATIONS ARE THE PROPERTY OF NorComp AND SHALL NOT BE REPRODUCED, COPIED OR USED AS THE BASIS FOR THE MANUFACTURE OF SALE OF APPARATUS WITHOUT WRITTEN PERMISSION.

DRAWN: WAYNE ROBBINS		DATE: 11-28-05	
CHECKED:		DATE:	
SCALE: 1:1	SHEET 1 OF 3	REV 10	
DWG NO. 174-EYY-21YRYY1			

RoHS COMPLIANT

NorComp

DESCRIPTION: PCB LAYOUT - STANDARD "D" - MALE & FEMALE

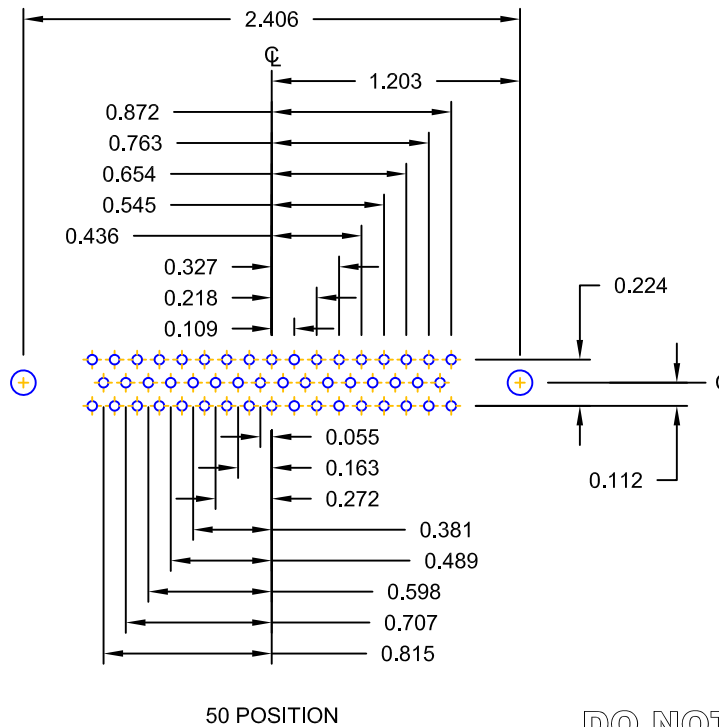
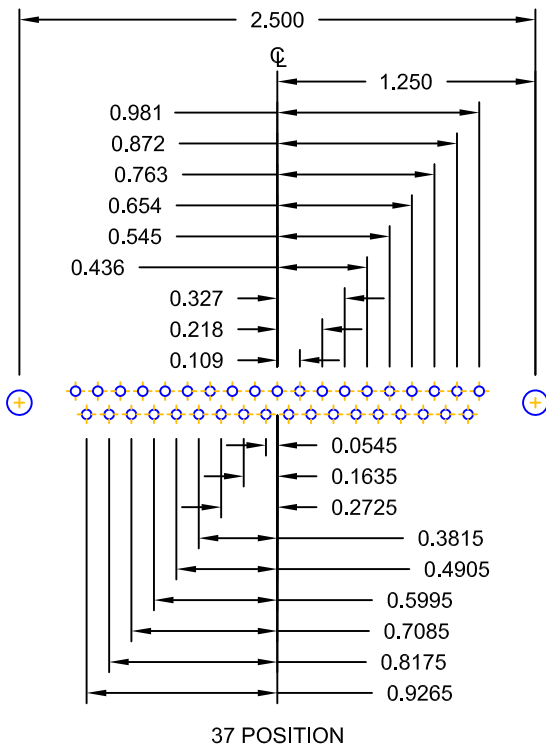
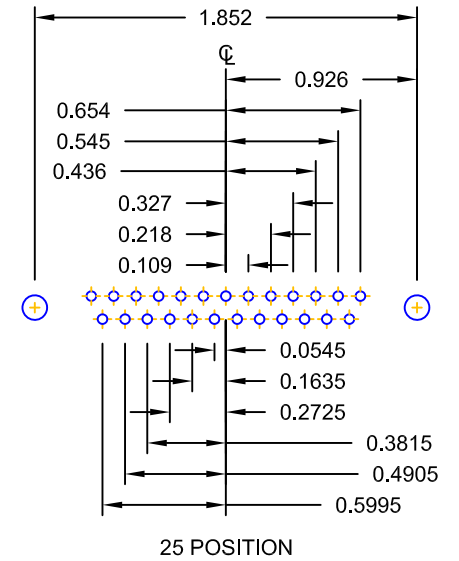
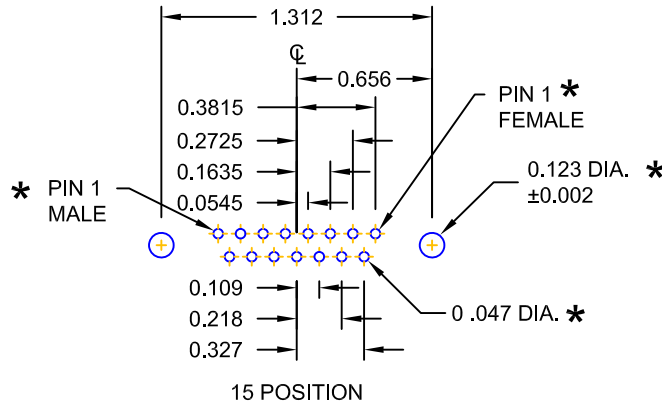
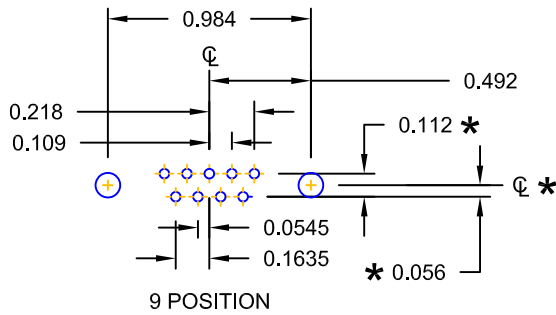

* TYP. ON ALL SIZES

DO NOT SCALE FROM DRAWING



THESE DRAWINGS AND SPECIFICATIONS ARE THE PROPERTY OF NorComp AND SHALL NOT BE REPRODUCED, COPIED OR USED AS THE BASIS FOR THE MANUFACTURE OF SALE OF APPARATUS WITHOUT WRITTEN PERMISSION.

DRAWN: C. SMITH		DATE: 03-08-06	
CHECKED:		DATE:	
SCALE: FULL	SHEET 2 OF 3	REV 10	
DWG NO. 174-EYY-21YRY1			

NorComp

DESCRIPTION: CLINCH NUT HARDWARE

173/174 SERIES

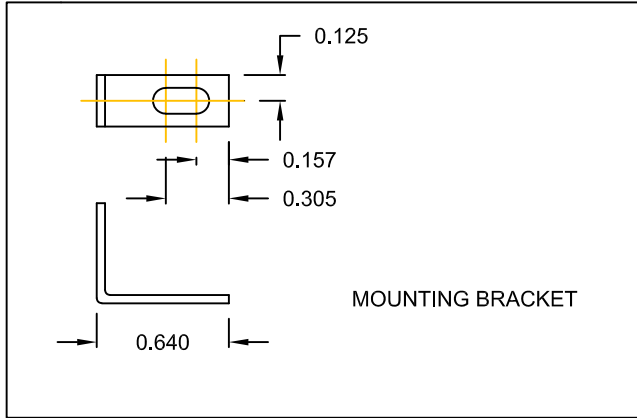

MOUNTING BRACKET

173 / 174 SERIES

- 14Y = SHORT BRACKET & 4-40 FEMALE HEX SOCKET
- 24Y = SHORT BRACKET & 4-40 SCREW

CLINCH-NUT HAS 4-40 INTERNAL THREADS

01X 0.098" (BOARD SIDE) - CN1

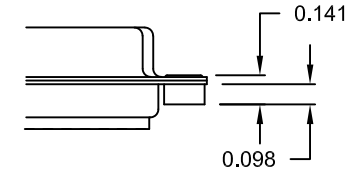

46Y = BRACKET WITH 4-40 INSERT AND BOARDLOCK

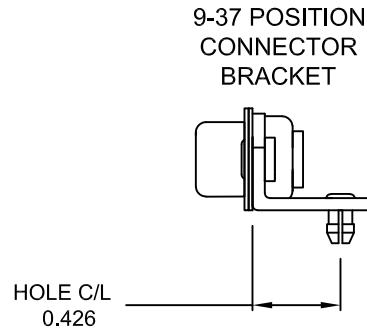

9-37 POSITION CONNECTOR BRACKET

HOLE C/L
0.426

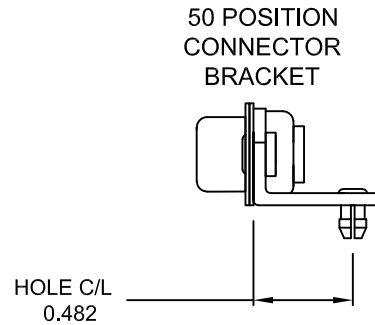

50 POSITION CONNECTOR BRACKET

HOLE C/L
0.482

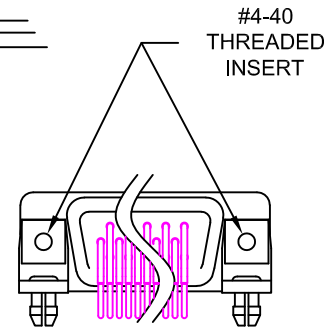

#4-40 THREADED INSERT

BRACKETS MOUNTED ON CONNECTOR

DO NOT SCALE FROM DRAWING

RoHS COMPLIANT



THESE DRAWINGS AND SPECIFICATIONS ARE THE PROPERTY OF NorComp AND SHALL NOT BE REPRODUCED, COPIED OR USED AS THE BASIS FOR THE MANUFACTURE OF SALE OF APPARATUS WITHOUT WRITTEN PERMISSION.

NorComp

DRAWN: PAM JENKINS		DATE: 11-28-05	
CHECKED:		DATE:	
SCALE: 1 : 1	SHEET 3	OF 3	REV 10
DWG NO. 174-EYY-21YRY1			