

DATE	REV	ECN	APP'D. BY
03-10-04	A2	6351	JMB
1-19-06	A3	7441	JM
2-9-11	A4	9125	SMN
5-23-12	A5	9476	SMN
1-7-15	A6	10173	TRM

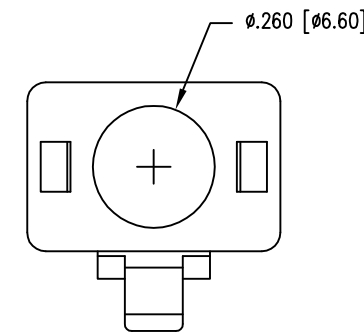
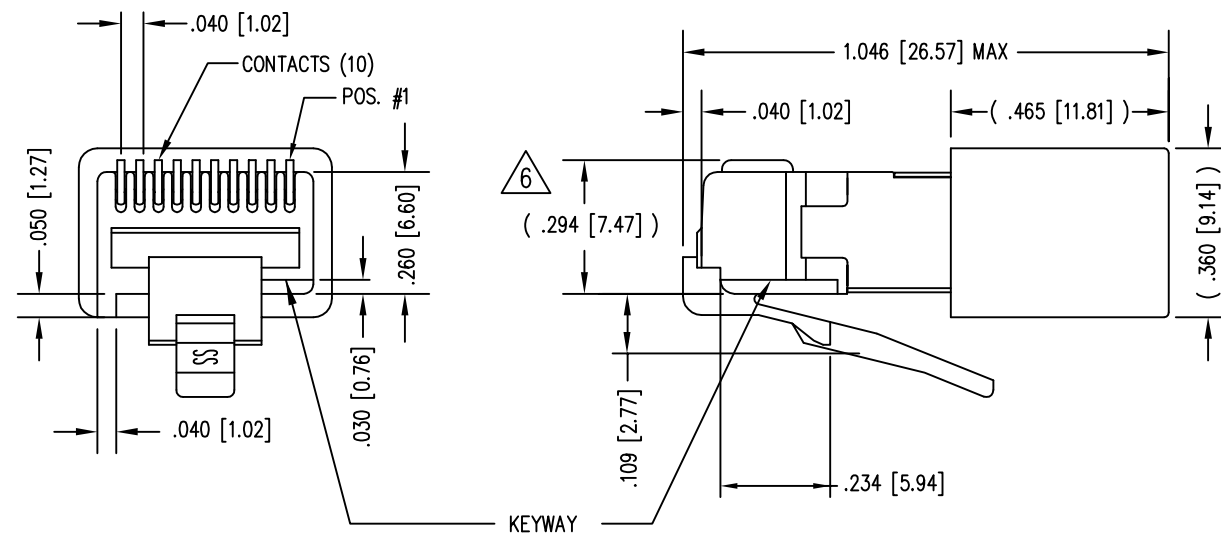
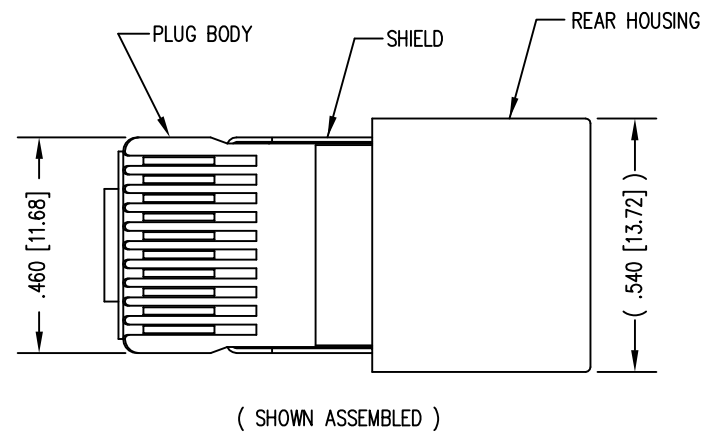

NOTES:

- 1- PLUG KIT CONSISTS OF :  
PRE-INSERTED PLUG HOUSING & SHIELD  
LOAD BAR  
FERRULE
- 2- MATERIALS :  
FRONT HOUSING PLASTIC : CLEAR POLYCARBONATE, UL 94-V0  
LOAD BAR : CLEAR POLYCARBONATE, UL 94-V0  
SHIELD : TIN PLATED BRASS  
CONTACTS : PHOSPHOR BRONZE, SELECTIVE GOLD PLATING  
FERRULE : NICKEL OR TIN PLATED BRASS
- 3- CONTACTS TERMINATE STRANDED CONDUCTORS UP TO .037 [0.94] OUTSIDE DIAMETER OF INSULATION.
- 4- FOR PLUG SPECIFICATION SEE PRO26-01.
- 5- DIMENSIONS & TOLERANCES COMPLY WITH TIA-1096 STANDARD
- 6- TERMINATED PLUG HEIGHT: .237 [6.02] ±.005 [0.13] ON CABLE

BULK	50 MICRO-INCHES [1.27um]	940-SP-361010-RMK4-A108
PACKAGE	CONTACT PLATING IN MATING AREA	PART NUMBER

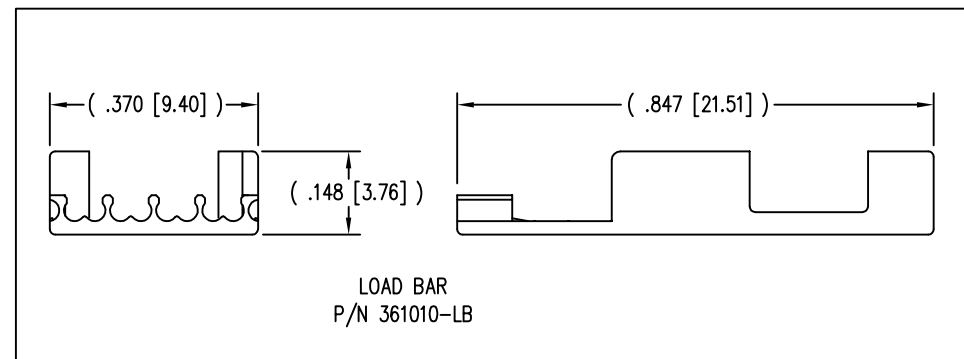
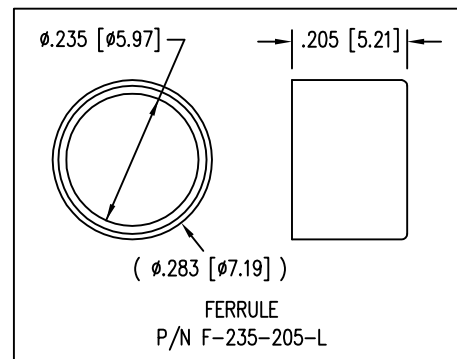

THIRD ANGLE PROJECTION

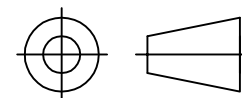

1118 Susquehanna Trail South  
Glen Rock, PA 17327-9199  
(717) 235-7512

<http://www.stewartconnector.com>

DO NOT SCALE DRAWING  
DRAWING IS SUBJECT TO  
CHANGE WITHOUT NOTICE

TITLE:  
10 X 10 SHIELDED PLUG WITH HOUSING

DIMENSIONS: INCHES [METRIC]  
UNLESS OTHERWISE SPECIFIED  
TOLERANCES ARE ±.005 [0.13]  
ANGLES ARE ± 1°

THIS DRAWING AND THE SUBJECT MATTER SHOWN THEREON ARE CONFIDENTIAL AND THE PROPRIETARY PROPERTY OF STEWART CONNECTOR AND SHALL NOT BE REPRODUCED, COPIED, OR USED IN ANY MANNER WITHOUT PRIOR WRITTEN CONSENT OF STEWART CONNECTOR. THIS PRODUCT MAY BE PROTECTED BY ONE OR MORE OF THE FOLLOWING US PATENTS:  
5628647 6402559 6409535 6524128  
7753717 8033863  
OTHER PATENTS MAY BE PENDING.

DRN BY:	RGC	DATE	11/1/01
APPD BY:	JRC	DATE	11/1/01
DWG NO.	CT360152	REV.	A6

SHEET NO.  
1 OF 1

