

THIS DRAWING IS UNPUBLISHED.

RELEASED FOR PUBLICATION

REVISIONS

© COPYRIGHT - TE Connectivity Ltd.

ALL RIGHTS RESERVED.

P	LTR	DESCRIPTION	DATE	DWN	APVD
1		NEW DRAWING	03MAY2018	GCM	AS

2331398-1 AND 2331398-2
AS SHOWN

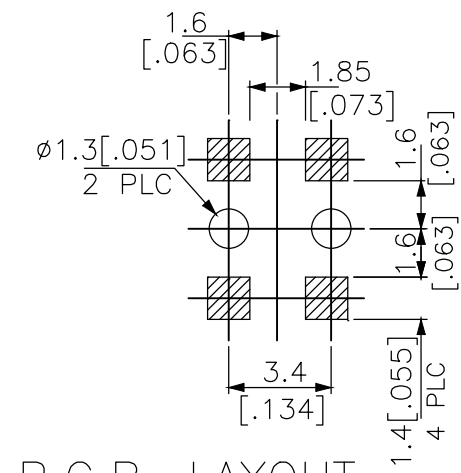
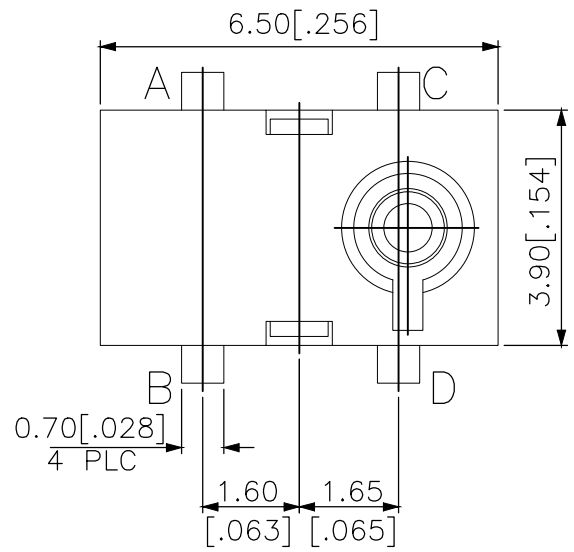

P.C.B. LAYOUT

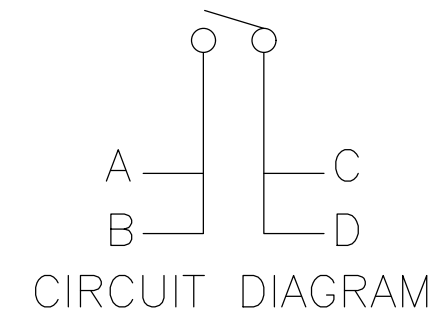
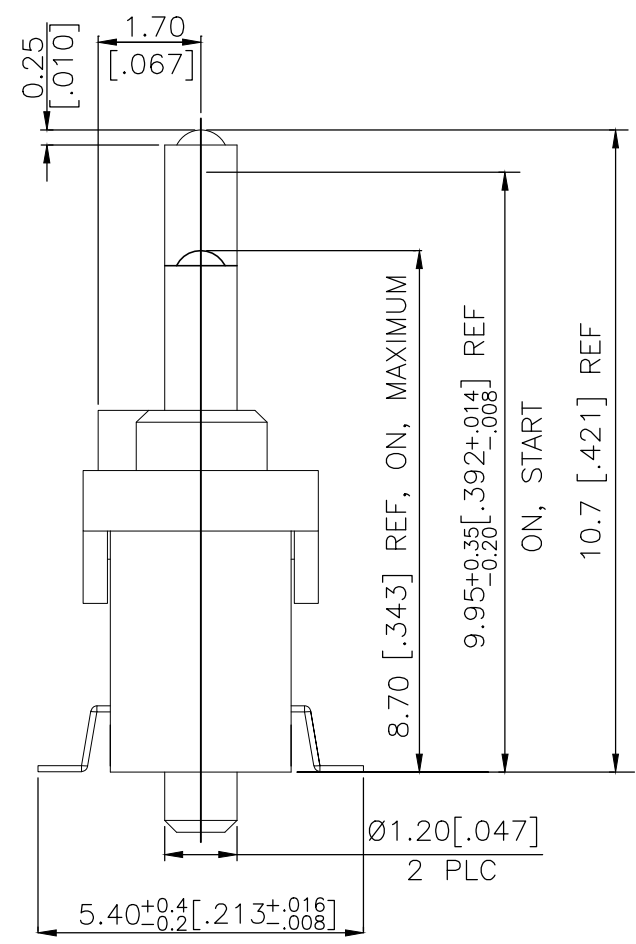
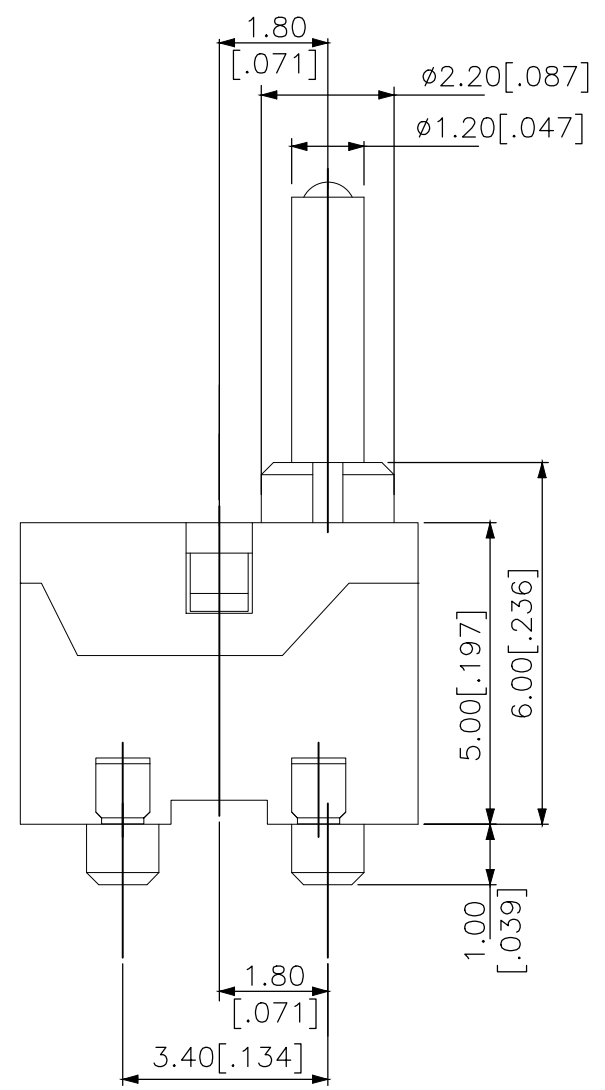

400	2331398-2
50	2331398-1
QTY PER REEL/TUBE	TE PART NO

PRELIMINARY

THIS DRAWING IS A CONTROLLED DOCUMENT.		DWN	GANESH C M		03MAY2018
DIMENSIONS: mm [INCHES]		CHK	ALEXANDER SHARPE		03MAY2018
TOLERANCES UNLESS OTHERWISE SPECIFIED:		APVD	ALEXANDER SHARPE		03MAY2018
<ul style="list-style-type: none"> 0 PLC ± - 1 PLC ± - 2 PLC ± 0.20 [.008] 3 PLC ± - 4 PLC ± - ANGLES ± - 		PRODUCT SPEC	NAME		
MATERIAL		APPLICATION SPEC	SWITCH, DETECTOR, JYL SERIES, 6.5X3.9mm, VERTICAL, SMT, POSTS, 10.7mm		
FINISH		WEIGHT	SIZE	CAGE CODE	DRAWING NO
			A3	00779	C-2331398
		CUSTOMER DRAWING	SCALE	SHEET	REV
			NTS	1 OF 3	1

THIS DRAWING IS UNPUBLISHED.

RELEASED FOR PUBLICATION

REVISIONS

© COPYRIGHT - TE Connectivity Ltd.

ALL RIGHTS RESERVED.

P	LTR	DESCRIPTION	DATE	DWN	APVD
-	-	SEE SHEET 1	-	-	-

PACKAGING:

- 2331398-1 : 50 SWITCHES PER TUBE
- 2331398-2 : 400 SWITCHES PER REEL

THE DIMENSION OF TUBE, CARRIER TAPE, COVER TAPE AND REEL

2331398-1

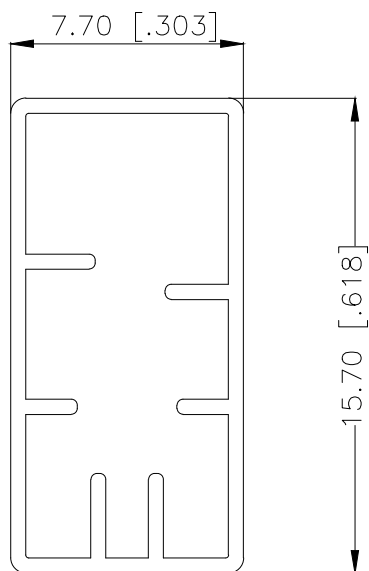

TUBE LENGTH: 500 [19.68] REF

2331398-2

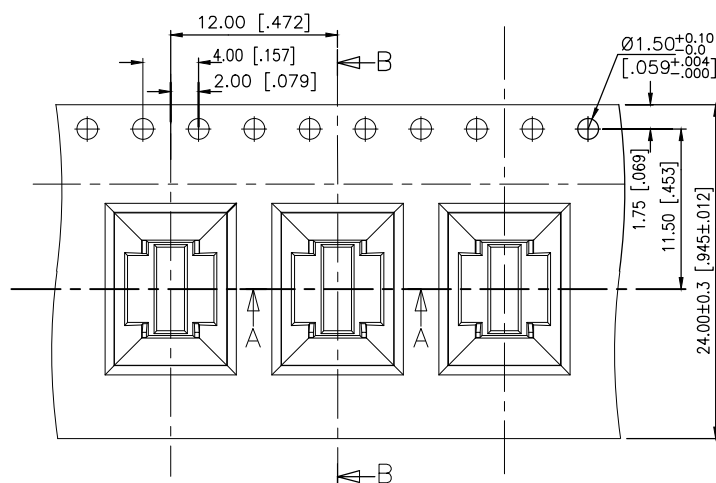

Section B-B

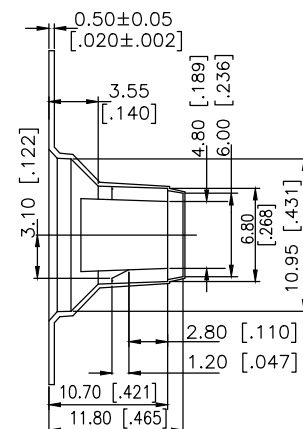

THE DIRECTION OF PILOT HOLES

CARRIER TAPE

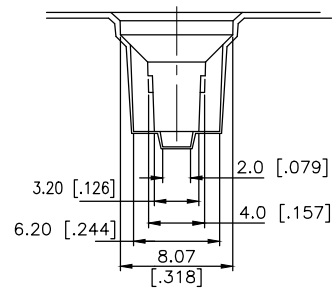
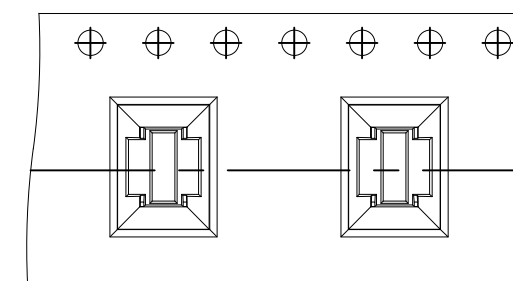

Section A-A

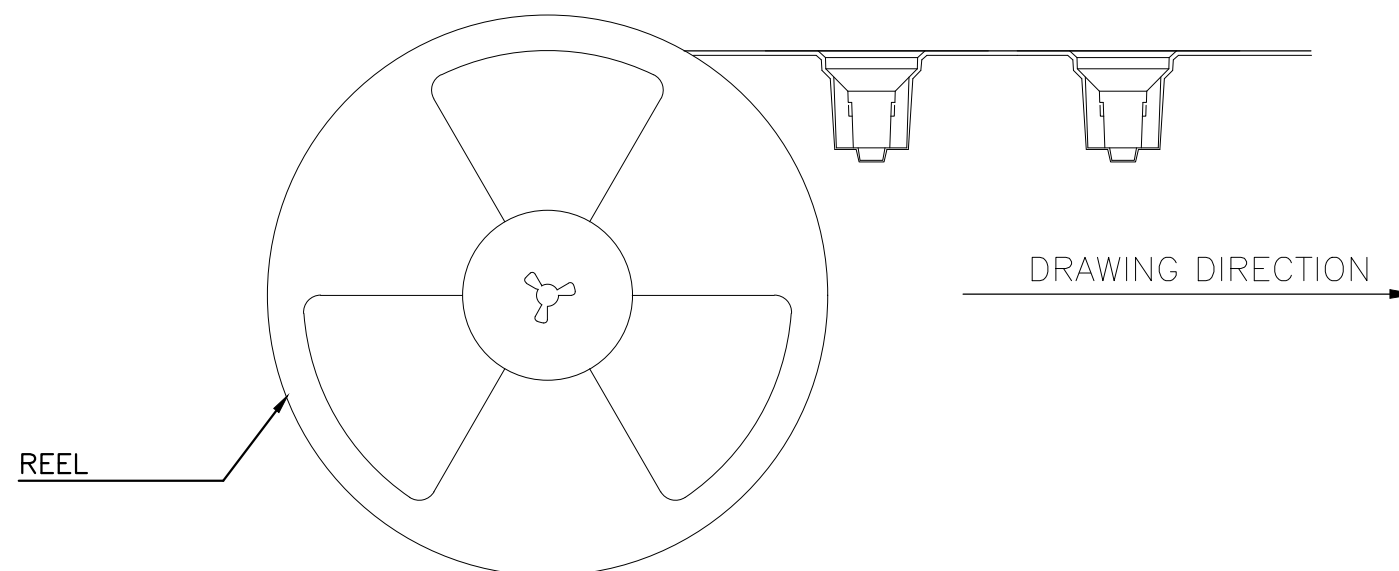

REEL

DRAWING DIRECTION

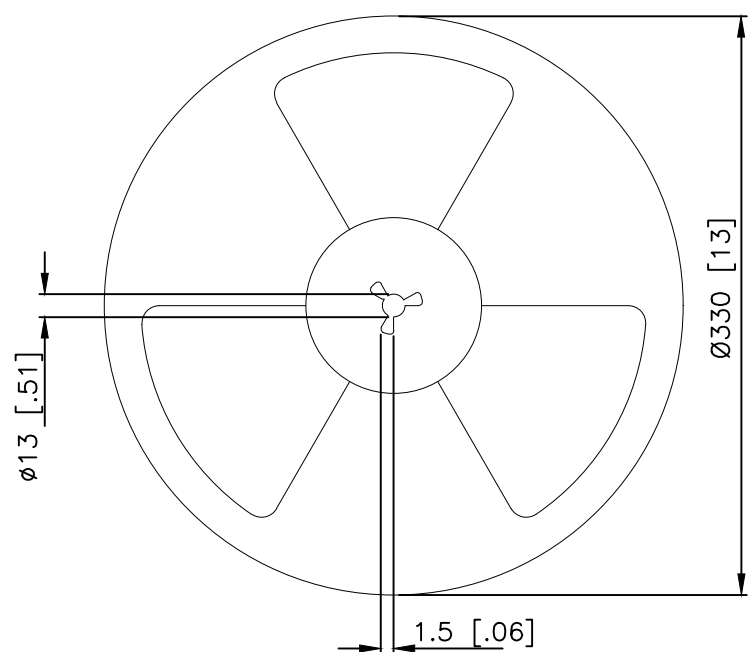

1.5 [0.06]

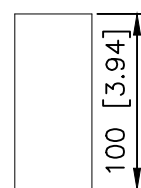

24 [0.94]

PRELIMINARY

THIS DRAWING IS A CONTROLLED DOCUMENT.		DWN GANESH C M 03MAY2018	 TE Connectivity Ltd.			
DIMENSIONS: mm [INCHES]		CHK ALEXANDER SHARPE 03MAY2018				NAME
TOLERANCES UNLESS OTHERWISE SPECIFIED:		APVD ALEXANDER SHARPE 03MAY2018	SWITCH, DETECTOR, JYL SERIES, 6.5X3.9mm, VERTICAL, SMT, POSTS, 10.7mm			
0 PLC ± -		PRODUCT SPEC	-			
1 PLC ± -		APPLICATION SPEC	-			
2 PLC ± 0.20 [0.008]		WEIGHT	SIZE A3	CAGE CODE 00779	DRAWING NO C-2331398	RESTRICTED TO
3 PLC ± -		CUSTOMER DRAWING				SCALE NTS
4 PLC ± -		SHEET 3 OF 3				REV 1
ANGLES ± -						
FINISH -						