

REVISIONS					
REV	ECO	DESCRIPTION	DATE	BY	APPR
A1	--	RELEASED DRAWING	Jun-30-2017	Nick	Tommy
A2	--	UPDATE DRAWING	Mar-16-2018	White	Tommy
A3	--	UPDATE DRAWING	Apr-10-2018	White	Tommy

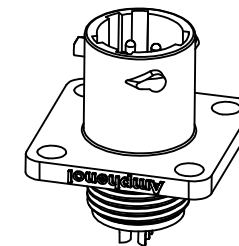

NOTES : (UNLESS OTHERWISE SPECIFIED)

- MATERIAL :  
SHELL : THERMOPLASTIC , UL94 V-0.  
INSERT : CHLOROPRENE RUBBER.  
SEAL GASKET : NBR.  
CONTACT : COPPER ALLOY , GOLD PLATED.
- SPECIFICATIONS :  
2.1 RATED CURRENT : 7A (MAX).  
2.2 RATED VOLTAGE : 250V(AC/DC).  
2.3 OPERATING TEMPERATURE : -40°C ~ +105°C .  
2.4 DIELECTRIC WITHSTANDING VOLTAGE : LESS THAN 2 MILLIAMPS CURRENT LEAKAGE@1500 VOLTS AC.  
2.5 INSULATION RESISTANCE : 5000 MEGOHMS MIN.  
2.6 IP--CLASS : IP67 AND IP69K IN THE MATED CONDITION, PANEL EXTERNAL.
- 2.7 MATING CYCLES DURABILITY : 500 CYCLES MIN.  
2.8 RoHS COMPLIANT.
- ALL DIMENSIONS ARE FOR REFERENCE USE ONLY.

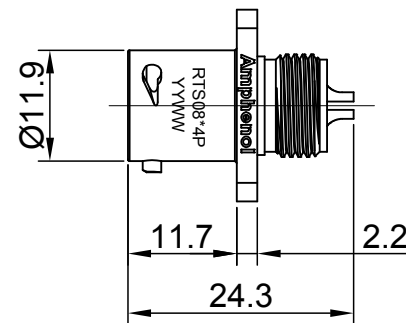
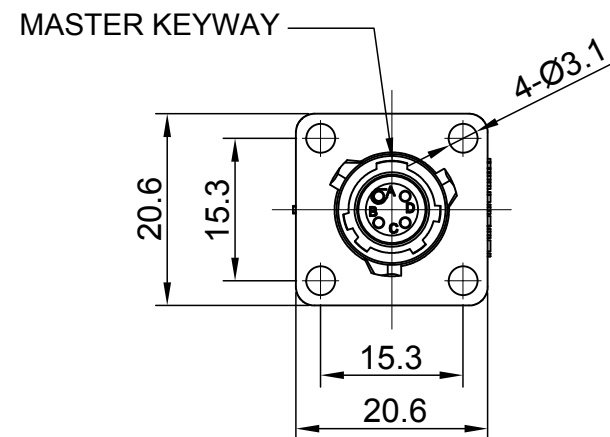
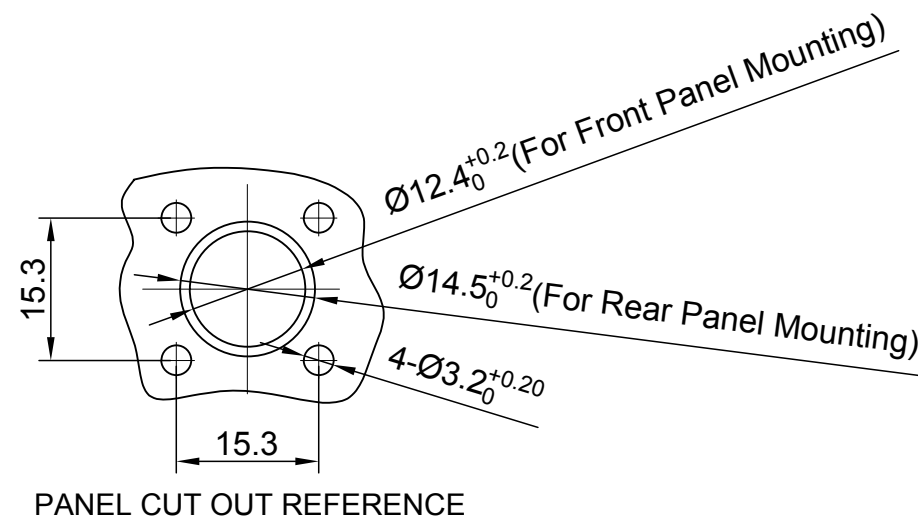

KEY	PART NUMBER
N	RTS08N4P

QUANTITY	PART NUMBER	DESCRIPTION	ITEM										
<b>MATERIALS LIST</b>													
UNLESS OTHERWISE SPECIFIED 1) All dimensions are in metric(mm). 2) Tolerances are as follows: 1 PL DEC ±0.30   Fractions ±1/64 2 PL DEC ±0.15   Angles ±1° 3 PL DEC ±0.08		<table border="1"> <thead> <tr> <th>SIGNATURES</th> <th>DATE</th> </tr> </thead> <tbody> <tr> <td>DRAWN: White</td> <td>Apr-10-2018</td> </tr> <tr> <td>CHECKED: Tod</td> <td>Apr-10-2018</td> </tr> <tr> <td>ENGINEER:</td> <td></td> </tr> <tr> <td>APPROVAL: Tommy</td> <td>Apr-10-2018</td> </tr> </tbody> </table>		SIGNATURES	DATE	DRAWN: White	Apr-10-2018	CHECKED: Tod	Apr-10-2018	ENGINEER:		APPROVAL: Tommy	Apr-10-2018
SIGNATURES	DATE												
DRAWN: White	Apr-10-2018												
CHECKED: Tod	Apr-10-2018												
ENGINEER:													
APPROVAL: Tommy	Apr-10-2018												
MATERIAL SPECIFICATIONS:		<p style="text-align: center;"><b>Amphenol</b></p> <p>Sine Systems - www.amphenol-sine.com 44724 Morley Drive Clinton Township, MI 48036</p> <p style="text-align: center;">ECO-MATE, RECEPTACLE, FLANGE, SIZE 8, 4 POS, PIN</p>											
PROCESS SPECIFICATIONS:													
NEXT ASSY:													
THIS DRAWING IS SUPPLIED FOR INFORMATION ONLY. DESIGN FEATURES, SPECIFICATIONS AND PERFORMANCE DATA SHOWN HEREON ARE THE PROPERTY OF THE AMPHENOL CORPORATION. NO RIGHTS OF REPRODUCTION ARE IMPLIED. ALL DIMENSIONS ARE SUBJECT TO NORMAL MANUFACTURING VARIATIONS.		<table border="1"> <tr> <td>SIZE</td> <td>TYPE</td> <td>DWG NO:</td> <td>REVISION</td> </tr> <tr> <td>B</td> <td>C-</td> <td>RTS08*4P</td> <td>A3</td> </tr> </table>	SIZE	TYPE	DWG NO:	REVISION	B	C-	RTS08*4P	A3			
SIZE	TYPE	DWG NO:	REVISION										
B	C-	RTS08*4P	A3										
SCALE: NONE		SHEET 1 OF 1											

TITLE: ECO-MATE, RECEPTACLE, FLANGE, SIZE 8, 4 POS, PIN

DWG NO:

RTS08\*4P

REV: A3

SH: 1

OF: 1