

Fig.1 Recommended PCB Layout
 (All dimensions are symmetric about the centerline)

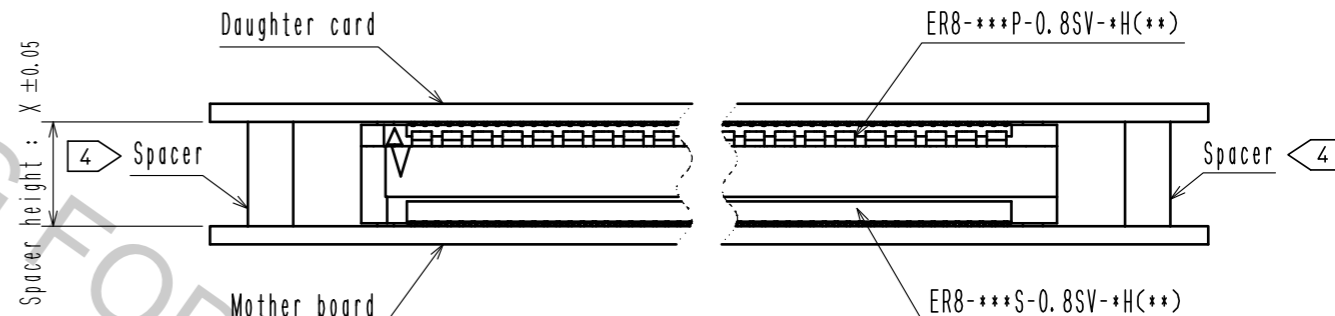
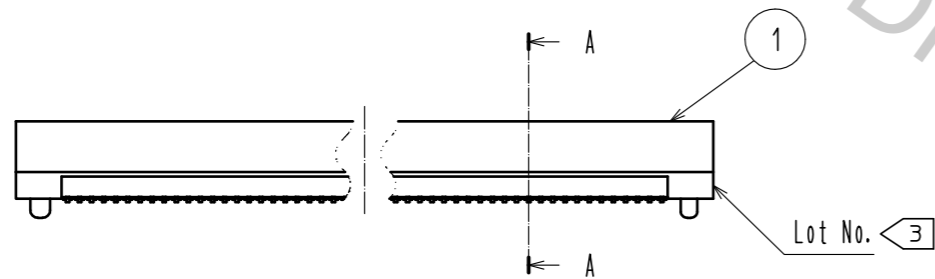
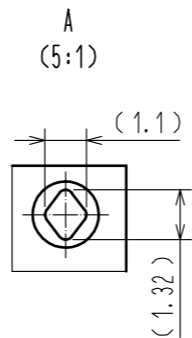
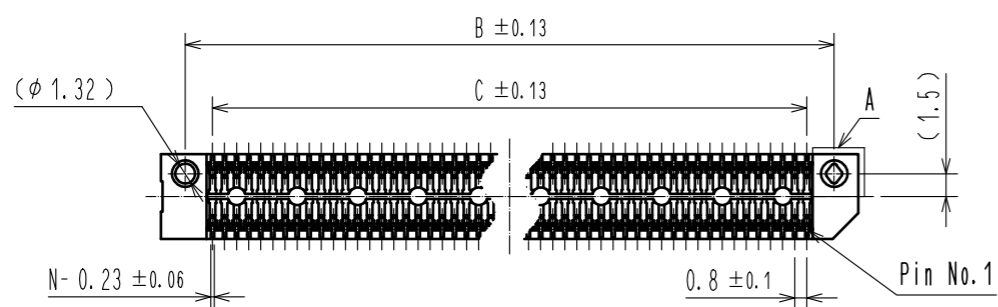

Fig.2 (Free)



- Note.
1. Dimensions in parentheses () are for reference.
 2. Packaging for this product applies embossed carrier tape packaging. See sheet 2/3 and 3/3 for details.
 - 3 Lot No. shall be marked on the indicated position.
 - 4 The indicated mother board and daughter card shall be gastedo the additional reinforcements to prevent the stress on ER8-***P-0.8SV-+H(**) and ER8-***S-0.8SV-+H(**).
 - 5 Plating specification are below.

Part No.	Plating specification
ER8-***S-0.8SV-+H	CONTACT AREA : Ni2.54 μm + Au0.76 μm
	LEAD AREA : Ni1.25 μm + Sn3.81 μm
ER8-***S-0.8SV-+H(10)	CONTACT AREA : Ni1.25 μm + Au0.25 μm
	LEAD AREA : Ni1.25 μm + Sn2.54 μm

Receptacle	Plug	Spacer height (X)
ER8-***S-0.8SV-5H(**)	ER8-***P-0.8SV-2H(**)	7.15
	ER8-***P-0.8SV-5H(**)	10.15
ER8-***S-0.8SV-7H(**)	ER8-***P-0.8SV-2H(**)	9.15
	ER8-***P-0.8SV-5H(**)	12.15

Table1 Spacer height △

3	POLYIMIDE	(TAPE FOR VACCUM PICK AND PLACE)	5	PE	(TOP COVER TAPE)
2	COPPER ALLOY	5	4	PS	(EMBOSSED CARRIER TAPE)
1	LCP	BLACK. UL94V-0			
NO.	MATERIAL	FINISH . REMARKS	NO.	MATERIAL	FINISH . REMARKS
UNITS mm	①	SCALE 2 : 1	COUNT 1	DESCRIPTION OF REVISIONS DIS-F-00002615	DESIGNED KT. AIZAWA
APPROVED : MK. EZAKI 16.06.20			CHECKED MK. EZAKI		
CHECKED : MK. NAGATA 16.06.20			DATE 17.08.30		
DESIGNED : TF. SUGAWARA 16.06.20			DRAWING NO. EDC-371041-00-00		
DRAWN : TF. SUGAWARA 16.06.20			PART NO. ER8-***S-0.8SV-+H(**)		
HRS HIROSE ELECTRIC CO., LTD.			CODE NO. CL625		

Oct.1.2018 Copyright 2018 HIROSE ELECTRIC CO., LTD. All Rights Reserved.
 In case that the application demands a high level of reliability, such as automotive,
 please contact a company representative for further information.

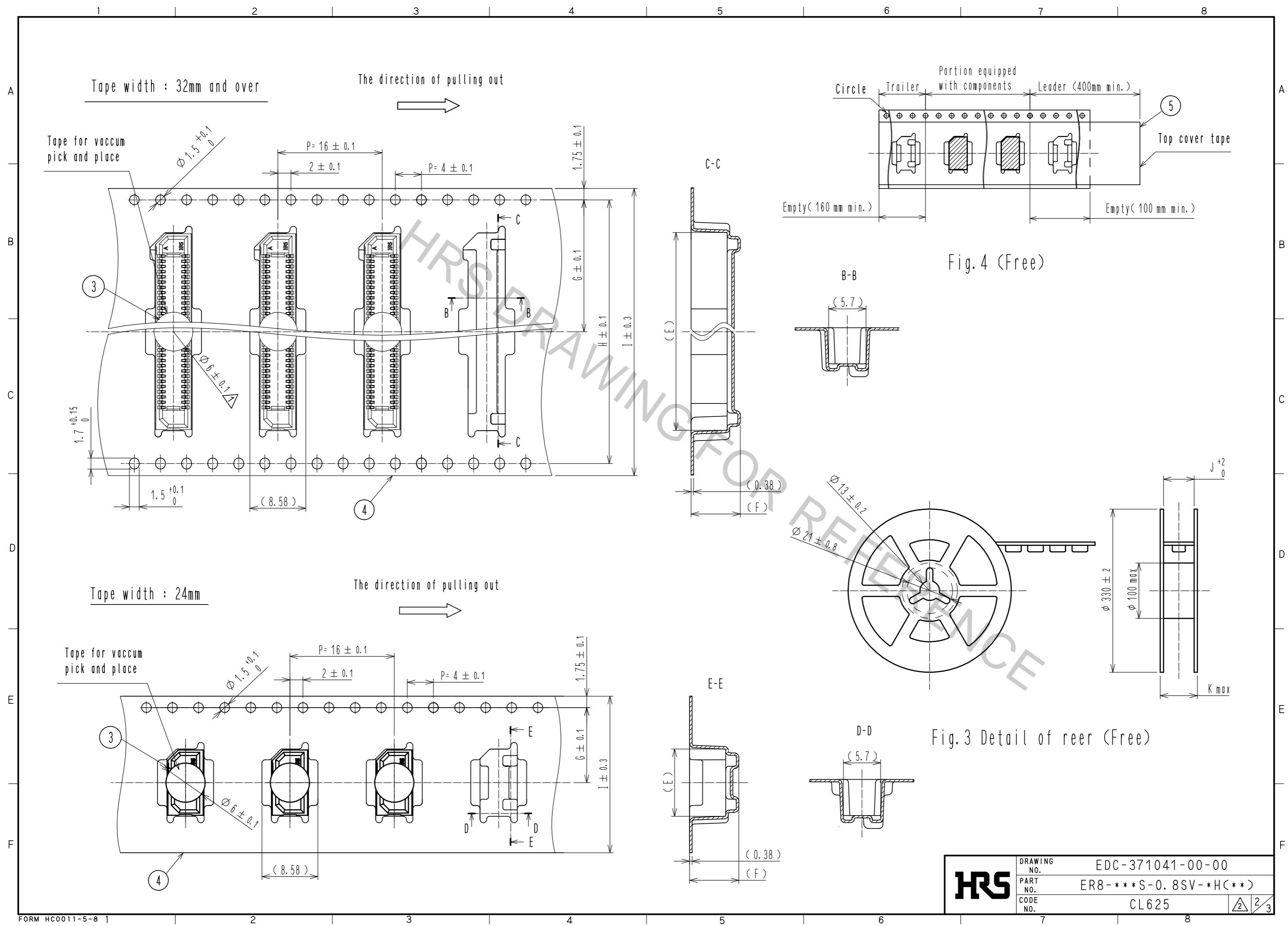

HRS	DRAWING NO.	EDC-371041-00-00
	PART NO.	ER8-***S-0.8SV-*H(**)
	CODE NO.	CL625
		2/3

Oct.1.2018 Copyright 2018 HIROSE ELECTRIC CO., LTD. All Rights Reserved.
 In case that the application demands a high level of reliability, such as automotive,
 please contact a company representative for further information.

Part No.	Code No.	Contact positions (N)	Dimensions											Co-planarity	Qty/reel
			A	B	C	D	E	F	G	H	I	J	K		
ER8-10S-0.8SV-5H(**)	CL625-0007-5-**-	10	10	6.8	3.2	5.335	10.3	7.55	11.5	-	24	24.4	30.4	0.1 Max	475
ER8-20S-0.8SV-5H(**)	CL625-0014-0-**-	20	14	10.8	7.2	5.335	14.3	7.55	14.2	28.4	32	32.4	38.4	0.1 Max	500
ER8-30S-0.8SV-5H(**)	CL625-0015-0-**-	30	18	14.8	11.2	5.335	18.3	7.55	20.2	40.4	44	44.4	50.4	0.1 Max	475
ER8-40S-0.8SV-5H(**)	CL625-0016-0-**-	40	22	18.8	15.2	5.335	22.3	7.55	20.2	40.4	44	44.4	50.4	0.1 Max	375
ER8-50S-0.8SV-5H(**)	CL625-0010-0-**-	50	26	22.8	19.2	5.335	26.3	7.55	20.2	40.4	44	44.4	50.4	0.1 Max	375
ER8-60S-0.8SV-5H(**)	CL625-0018-0-**-	60	30	26.8	23.2	5.335	30.3	7.55	20.2	40.4	44	44.4	50.4	0.1 Max	375
ER8-70S-0.8SV-5H(**)	CL625-0032-0-**-	70	34	30.8	27.2	5.335	34.3	7.55	26.2	52.4	56	56.4	62.4	0.12 Max	375
ER8-80S-0.8SV-5H(**)	CL625-0033-0-**-	80	38	34.8	31.2	5.335	38.3	7.55	26.2	52.4	56	56.4	62.4	0.12 Max	375
ER8-100S-0.8SV-5H(**)	CL625-0034-0-**-	100	46	42.8	39.2	5.335	46.3	7.55	34.2	68.4	72	72.4	89	0.12 Max	375
ER8-120S-0.8SV-5H(**)	CL625-0035-0-**-	120	54	50.8	47.2	5.335	54.3	7.55	34.2	68.4	72	72.4	89	0.12 Max	375
ER8-10S-0.8SV-7H(**)	CL625-0036-0-**-	10	10	6.8	3.2	7.25	10.3	9.45	11.5	-	24	24.4	30.4	0.1 Max	400
ER8-20S-0.8SV-7H(**)	CL625-0037-0-**-	20	14	10.8	7.2	7.25	14.3	9.45	14.2	28.4	32	32.4	38.4	0.1 Max	375
ER8-30S-0.8SV-7H(**)	CL625-0038-0-**-	30	18	14.8	11.2	7.25	18.3	9.45	20.2	40.4	44	44.4	50.4	0.1 Max	400
ER8-40S-0.8SV-7H(**)	CL625-0039-0-**-	40	22	18.8	15.2	7.25	22.3	9.45	20.2	40.4	44	44.4	50.4	0.1 Max	300
ER8-50S-0.8SV-7H(**)	CL625-0040-0-**-	50	26	22.8	19.2	7.25	26.3	9.45	20.2	40.4	44	44.4	50.4	0.1 Max	300
ER8-60S-0.8SV-7H(**)	CL625-0041-0-**-	60	30	26.8	23.2	7.25	30.3	9.45	26.2	52.4	56	56.4	62.4	0.1 Max	300
ER8-70S-0.8SV-7H(**)	CL625-0042-0-**-	70	34	30.8	27.2	7.25	34.3	9.45	26.2	52.4	56	56.4	62.4	0.12 Max	300
ER8-80S-0.8SV-7H(**)	CL625-0043-0-**-	80	38	34.8	31.2	7.25	38.3	9.45	26.2	52.4	56	56.4	62.4	0.12 Max	300
ER8-100S-0.8SV-7H(**)	CL625-0044-0-**-	100	46	42.8	39.2	7.25	46.3	9.45	34.2	68.4	72	72.4	89	0.12 Max	300
ER8-120S-0.8SV-7H(**)	CL625-0045-0-**-	120	54	50.8	47.2	7.25	54.3	9.45	34.2	68.4	72	72.4	89	0.12 Max	300

Table2 Dimensions

HRS	DRAWING NO.	EDC-371041-00-00
	PART NO.	ER8-***S-0.8SV-*H(**)
	CODE NO.	CL625
		3/3