

RECOMMENDED LAND PATTERN DIMENSION OF PCB  
 (RECOMMENDED METAL MASK THICKNESS: 0.15mm)

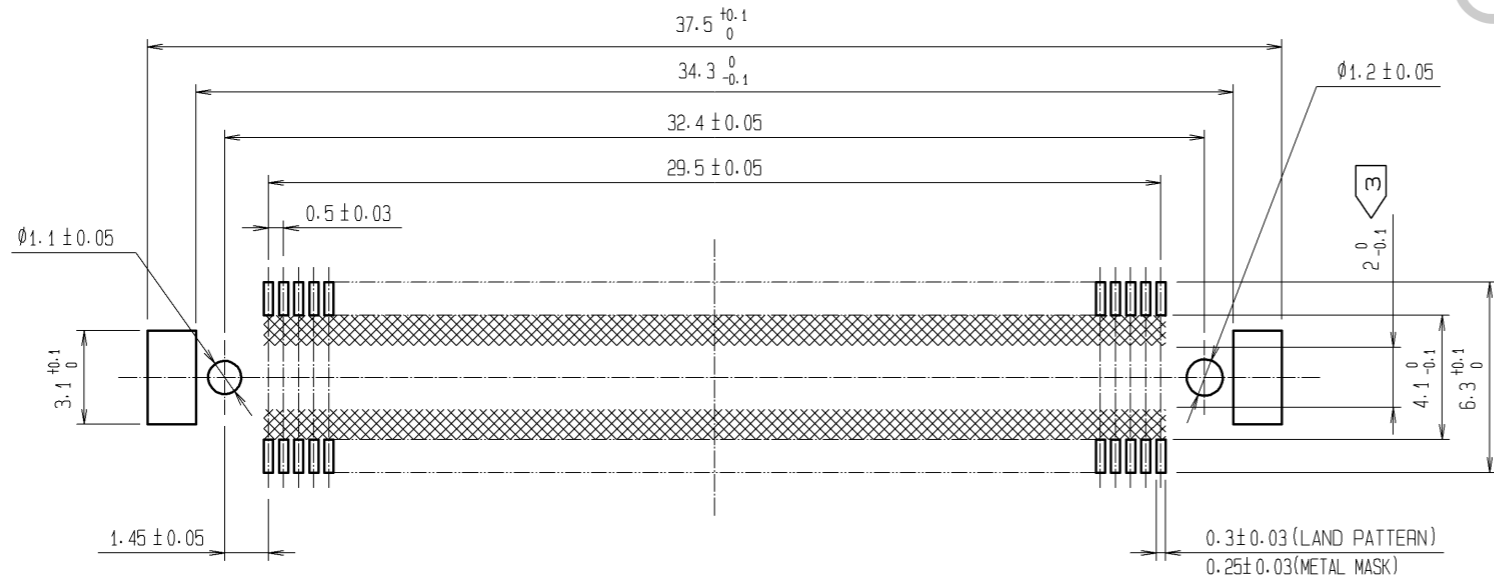

- NOTES
- 1 SMT LEAD-COPLANARITY: 0.1 MAX.
  - 2 THIS PRODUCT HAS NO POLARITY TO PATTERN FOR MOUNTING.
  - 3 MAKE SURE WIDTH OF PATTERN IS WITHIN THAT OF LAND, OR LEAD MAY TOUCH PATTERN. (THIS APPLIES TO HATCHED AREA.)
  - 4 EMBOSS CARRIER TAPE PACKAGE IS APPLIED ON THIS PRODUCT. PLEASE REFER TO THE SHEET 2/2 FOR THE DETAILS.
  - 5 THE DIMENSIONS IN PARENTHESES ARE FOR REFERENCE.

3	PHOSPHOR BRONZE	TIN-PLATING						
2	PHOSPHOR BRONZE	CONTACT AREA: GOLD 0.1μm min. LEAD AREA: TIN-PLATING 1μm min. UNDER PLATING: NICKEL 1μm min.	5	POLYESTER	TOP COVER TAPE			
1	LCP	BEIGE UL94V-0	4	POLYSTYRENE	EMBOSSED CARRIER TAPE			
NO.	MATERIAL	FINISH	REMARKS	NO.	MATERIAL	FINISH	REMARKS	
UNITS	mm	SCALE	4:1	COUNT	DESCRIPTION OF REVISIONS	DESIGNED	CHECKED	DATE
APPROVED: HS. OKAWA		10.04.23		DRAWING NO.		EDC3-151969-21		
CHECKED: HT. YAMAGUCHI		10.04.23		PART NO.		FX10A-120P-SV1(91)		
DESIGNED: SY. KAMIGA		10.04.23		CODE NO.		CL570-0142-7-91		
DRAWN: HK. SUNADORI		10.04.22						

# DRAWING FOR PACKING(2:1)

REELED DIMENSION(Free)

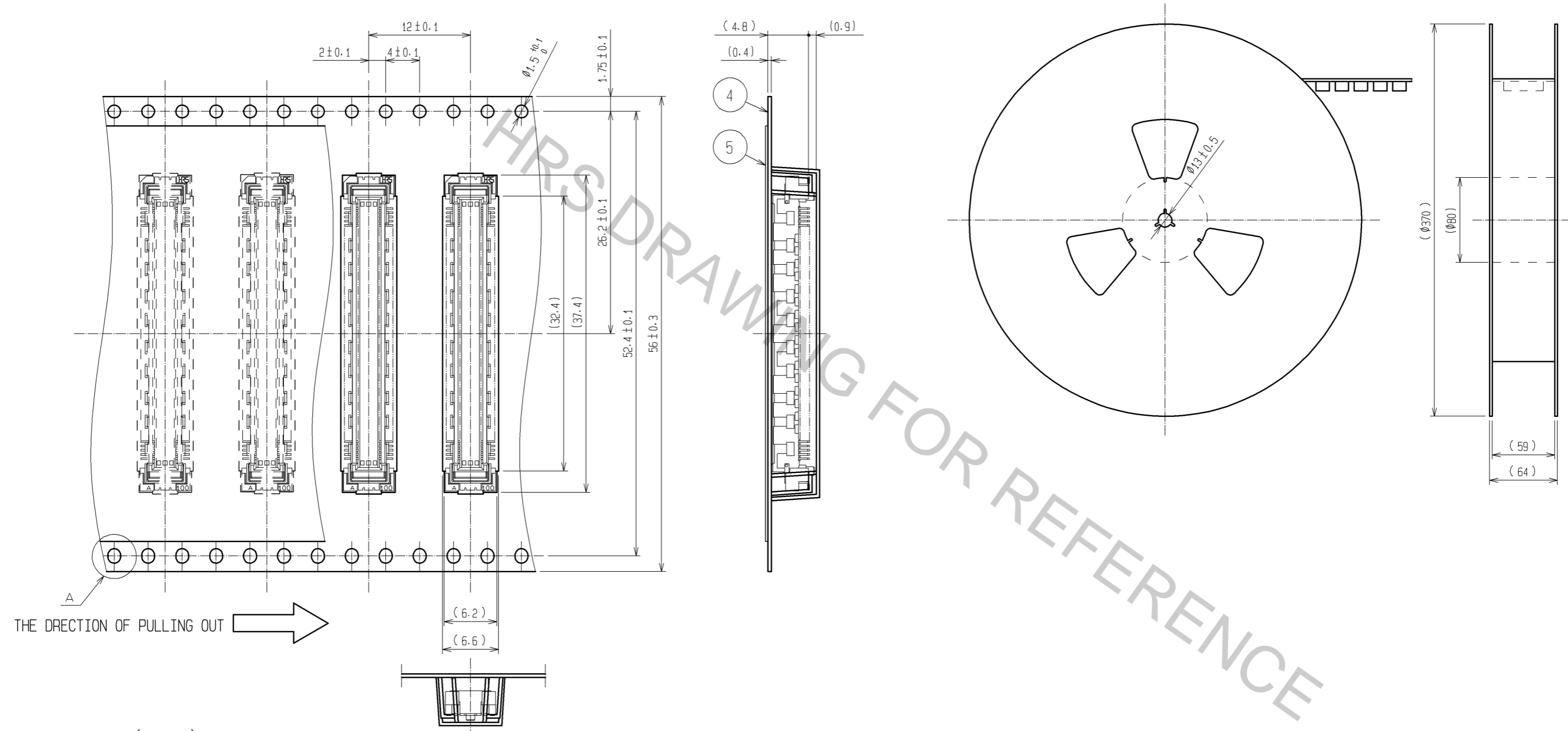

- NOTES
- 1 REEL : 1000 CONNECTORS.
  - 2 MINIMUM 10 COMPARTMENTS FROM BOTH REEL ENDS REMAIN EMPTY.
  - 3 THIS PRODUCT HAS NO POLAVITY TO TAPE AND REEL PACKAGING.
  - 4 THE DIMENSIONS IN PARENTHESES ARE FOR REFERENCE.

<b>HRS</b>	DRAWING NO.	EDC3-151969-21
	PART NO.	FX10A-120P-SV1(91)
	CODE NO.	CL570-0142-7-91
		$\triangle 2/2$

Oct.1.2018 Copyright 2018 HIROSE ELECTRIC CO., LTD. All Rights Reserved.  
 In case that the application demands a high level of reliability, such as automotive,  
 please contact a company representative for further information.