

PART NAME: KNOB SCALE: 1:1 DATE: 11/1/16 DR. BY JAM

THIS DRAWING IS THE PROPERTY OF DAVIES MOLDING COMPANY, IS SUBMITTED SOLELY AS A DESIGN OR ENGINEERING PROJECT. WE ACCEPT NO RESPONSIBILITY WHATSOEVER FOR THE PRACTICAL APPLICATION OF THE PIECES MADE TO THIS DESIGN.

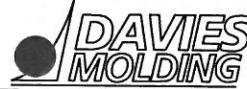

DESIGNERS & MANUFACTURERS OF KNOBS, HANDLES, CASES & CUSTOM PLASTIC COMPONENTS

P/N 2830DG-ED

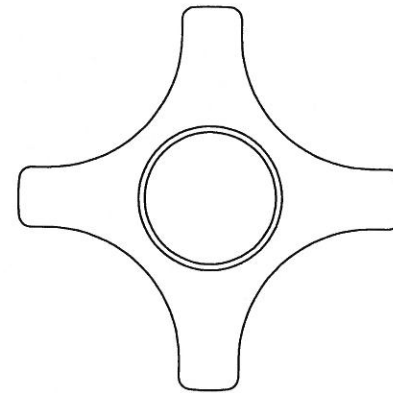

	THREAD	A	B	C	D
2830DG	M8 X 1.25	50	25	22	12
2830AF	M10 X 1.5	50	25	22	15

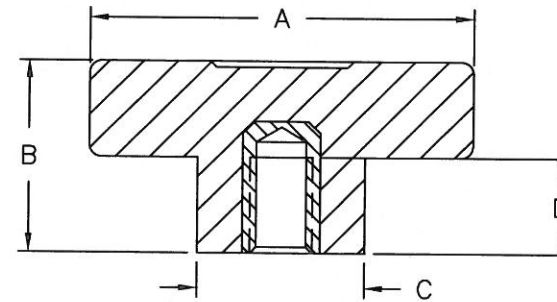

	THREAD	A	B	C	D
2830EA	M8 X 1.25	50	25	22	20
2830EB	M8 X 1.25	50	25	22	30
2830EC	M10 X 1.5	50	25	22	20
2830ED	M10 X 1.5	50	25	22	30

THREADED INTERNAL INSERT

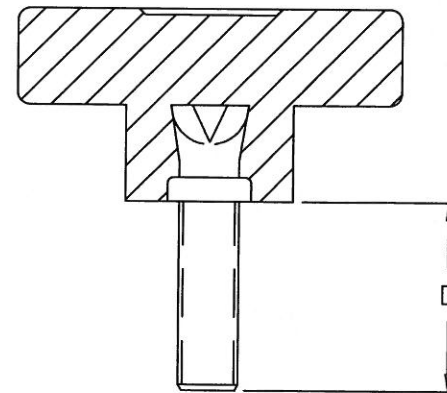

THREADED STUD

KNOB MATERIAL: PHENOLIC
COLOR: BLACK

INSERT MATERIAL: INTERNAL INSERTS ARE BRASS,
PROJECTING STUDS ARE ZINC PLATED STEEL

TOLERANCES: UNLESS OTHERWISE SPECIFIED	DO NOT SCALE DRAWING			
	MM: X.XX ± 0.15MM X.X ± 0.4MM			
	ANG. ± 1°	CHANGES		