

PART NAME: KNOB    SCALE: 1:1    DATE: 4/7/16    DR. BY JAM

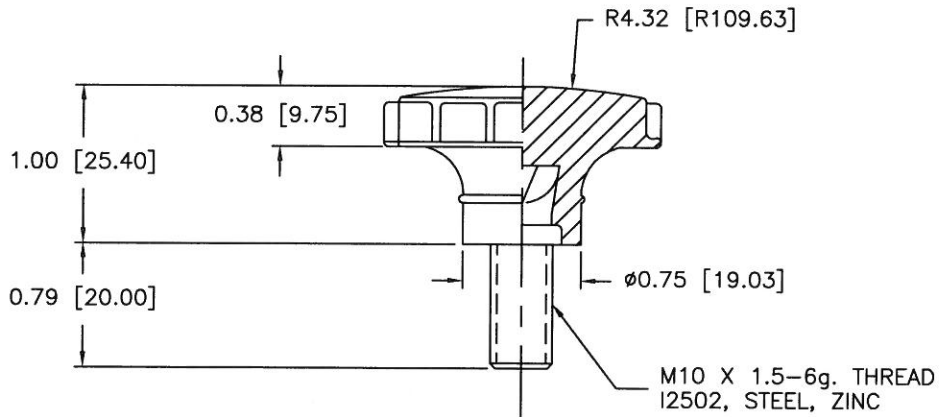

P/N 3000QG	
M NO. 3000	
CAVITY	3000
PLUNGER	3000
SHIM	1/4
PIN	3000-J-2
INSERT	I2502

THIS DRAWING IS THE PROPERTY OF DAVIES MOLDING COMPANY, IS SUBMITTED SOLELY AS A DESIGN OR ENGINEERING PROJECT. WE ACCEPT NO RESPONSIBILITY WHATSOEVER FOR THE PRACTICAL APPLICATION OF THE PIECES MADE TO THIS DESIGN.

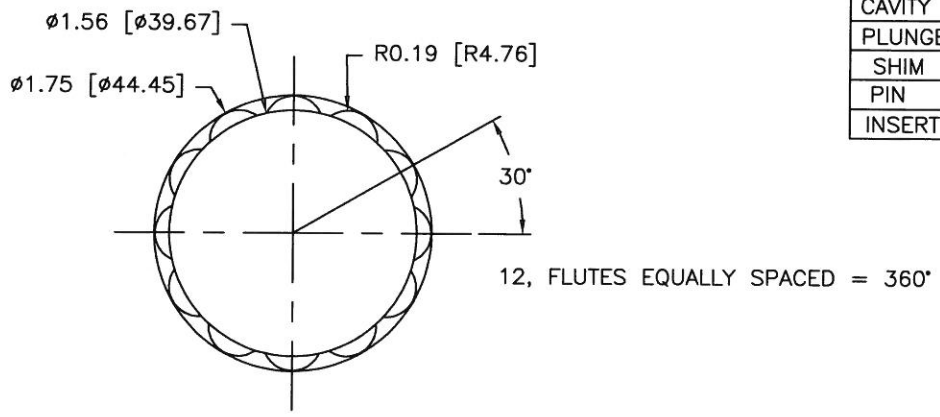

MATERIAL: #2567 PHENOLIC (R67)  
COLOR: RED

TOLERANCES: UNLESS OTHERWISE SPECIFIED	DO NOT SCALE DRAWING			
DECIMALS: X.XXX ± .005 X.XX ± .015	MM: X.XX ± 0.15MM X.X ± 0.4MM	-	WAS SK3000-57	JAM 4/7/16
FRACTIONS ± 1/64	ANG. ± 1'	CHANGES		