

REVISIONS					
REV	ECO	DESCRIPTION	DATE	BY	APPR
A1	--	RELEASED DRAWING	Jun-20-2018	Blink	Tommy

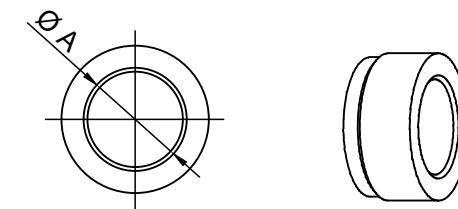
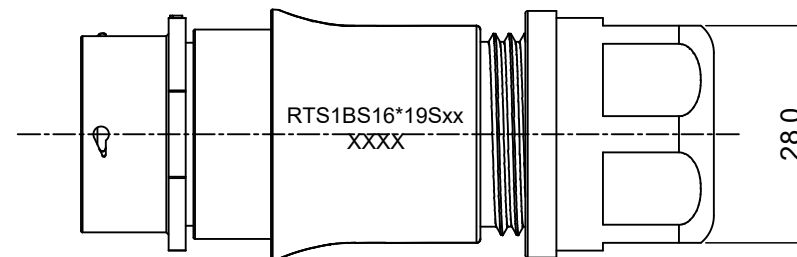
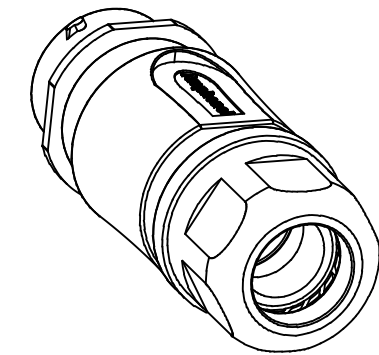
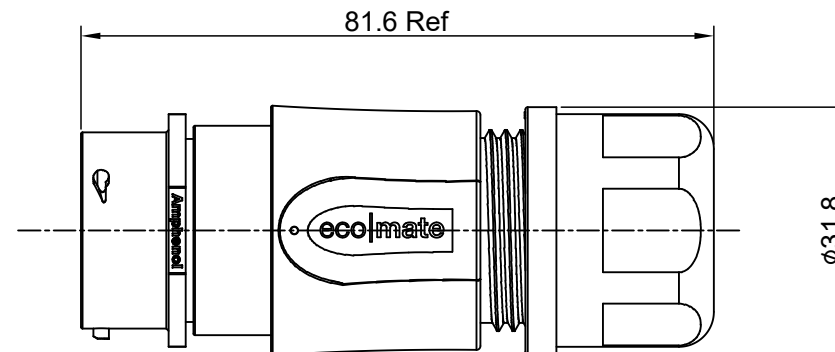
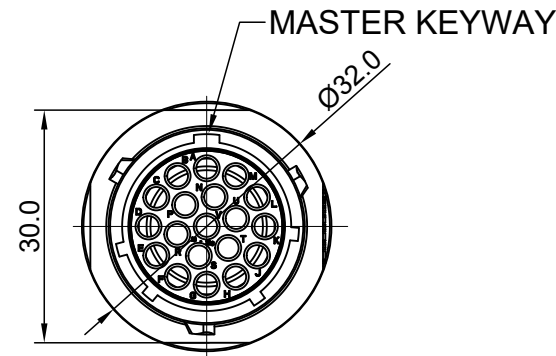

NOTES: (UNLESS OTHERWISE SPECIFIED)

- MATERIAL:
 - SHELL: THERMOPLASTIC, UL94 V-0.
 - INSERT: THERMOPLASTIC, UL94 V-0.
 - O-RING: NBR/SILICONE RUBBER.
 - BACK SHELL: THERMOPLASTIC, UL94 V-0.
 - CLAMP NUT: THERMOPLASTIC, UL94 V-0.
 - CLAMP RING: THERMOPLASTIC, UL94 V-0.
 - CABLE SEAL: EPDM.
- SPECIFICATIONS:
 - RATED CURRENT : 13A (MAX) .
 - RATED VOLTAGE: 500V(AC/DC).
 - OPERATING TEMPERATURE: SEE TABLE .
 - DIELECTRIC WITHSTANDING VOLTAGE: LESS THAN 2 MILLIAMPS CURRENT LEAKAGE@2000 VOLTS AC.
 - INSULATION RESISTANCE: 5000 MEGOHMS MIN.
 - IP--CLASS: IP67 AND IP69K IN THE MATED CONDITION.
 - MATING CYCLES DURABILITY: 500 CYCLES MIN.
 - RoHS COMPLIANT.
- SUITABLE CONTACTS : 16# CONTACT.
- ALL DIMENSIONS ARE FOR REFERENCE USE ONLY.
- ADD LOCTITE TO RETAIN BACKSHELL DURING UN-MATING AND TO PROVIDE ADDITIONAL PROTECTION AGAINST VIBRATION.

DIMENSION ϕA	CABLE OD RANGE
14.5MM	10.0-14.0mm
17.5MM	13.5-17.0mm

KEY	PART NUMBER	
	-40°C ~ 105°C	-40°C ~ 125°C
N	RTS1BS16N19S	RTS1BS16N19S03

QUANTITY	PART NUMBER	DESCRIPTION	ITEM										
MATERIALS LIST													
UNLESS OTHERWISE SPECIFIED 1) All dimensions are in metric(mm). 2) Tolerances are as follows: 1 PL DEC ±0.30 2 PL DEC ±0.15 3 PL DEC ±0.08 3) Note reference =		<table border="1"> <thead> <tr> <th>SIGNATURES</th> <th>DATE</th> </tr> </thead> <tbody> <tr> <td>DRAWN: Blink</td> <td>Jun-20-2018</td> </tr> <tr> <td>CHECKED: Tod</td> <td>Jun-20-2018</td> </tr> <tr> <td>ENGINEER:</td> <td></td> </tr> <tr> <td>APPROVAL: Tommy</td> <td>Jun-20-2018</td> </tr> </tbody> </table>		SIGNATURES	DATE	DRAWN: Blink	Jun-20-2018	CHECKED: Tod	Jun-20-2018	ENGINEER:		APPROVAL: Tommy	Jun-20-2018
SIGNATURES	DATE												
DRAWN: Blink	Jun-20-2018												
CHECKED: Tod	Jun-20-2018												
ENGINEER:													
APPROVAL: Tommy	Jun-20-2018												
MATERIAL SPECIFICATIONS:		<p style="text-align: center;">Amphenol</p> <p>Sine Systems - www.amphenol-sine.com 44724 Morley Drive Clinton Township, MI 48036</p> <p style="text-align: center;">ECO-MATE, RECPTACLE, BACK SHELL, SIZE 16, 19 POS, SOCKET</p>											
PROCESS SPECIFICATIONS:													
NEXT ASSY:		<table border="1"> <thead> <tr> <th>SIZE</th> <th>TYPE</th> <th>DWG NO:</th> <th>REVISION</th> </tr> </thead> <tbody> <tr> <td>B</td> <td>C-</td> <td>RTS1BS16*19Sxx</td> <td>A1</td> </tr> </tbody> </table>	SIZE	TYPE	DWG NO:	REVISION	B	C-	RTS1BS16*19Sxx	A1			
SIZE	TYPE	DWG NO:	REVISION										
B	C-	RTS1BS16*19Sxx	A1										
SCALE: NONE		SHEET 1 OF 1											

TITLE: ECO-MATE RECTANGLE BACK SHELL, SIZE 16, 19 POS, SOCKET. DWG NO: RTS1BS16*19Sxx REV: A1 SH: 1 OF: 1