

PART NAME: KNOB SCALE: 1:1 DATE: 11/1/16 DR. BY JAM

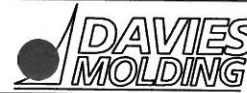

DESIGNERS & MANUFACTURERS OF KNOBS, HANDLES, CASES & CUSTOM PLASTIC COMPONENTS

P/N 3089BR-BW

THIS DRAWING IS THE PROPERTY OF DAVIES MOLDING COMPANY, IS SUBMITTED SOLELY AS A DESIGN OR ENGINEERING PROJECT. WE ACCEPT NO RESPONSIBILITY WHATSOEVER FOR THE PRACTICAL APPLICATION OF THE PIECES MADE TO THIS DESIGN.

	THREAD	A	B	C	D
3089BR	M6 X 1	51	28	19	12
3089BS	M8 X 1.25	51	28	19	12

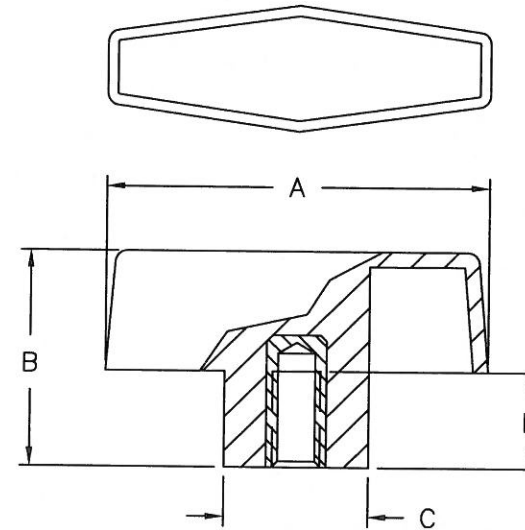

THREADED INTERNAL INSERT

	THREAD	A	B	C	D
3089BT	M6 X 1	51	28	19	20
3089BU	M6 X 1	51	28	19	30
3089BV	M8 X 1.25	51	28	19	20
3089BW	M8 X 1.25	51	28	19	30

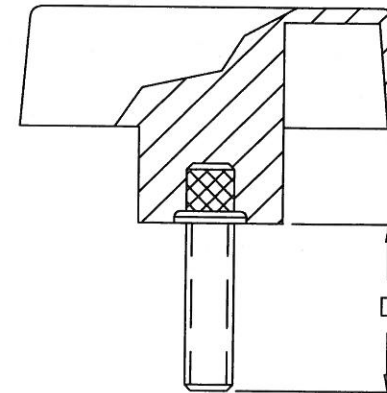

THREADED STUD

KNOB MATERIAL: POLYPROPYLENE
COLOR: BLACK

INSERT MATERIAL: INTERNAL INSERTS ARE BRASS,
PROJECTING STUDS ARE ZINC PLATED STEEL

TOLERANCES: UNLESS OTHERWISE SPECIFIED	DO NOT SCALE DRAWING			
	MM: X.XX ± 0.15MM X.X ± 0.4MM			
	ANG. ± 1°	CHANGES		