

PART NAME: KNOB      SCALE: 1:1      DATE: 11/1/16      DR. BY JAM

THIS DRAWING IS THE PROPERTY OF DAVIES MOLDING COMPANY, IS SUBMITTED SOLELY AS A DESIGN OR ENGINEERING PROJECT. WE ACCEPT NO RESPONSIBILITY WHATSOEVER FOR THE PRACTICAL APPLICATION OF THE PIECES MADE TO THIS DESIGN.

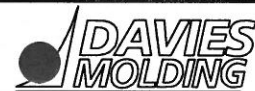

DESIGNERS & MANUFACTURERS OF KNOBS, HANDLES, CASES & CUSTOM PLASTIC COMPONENTS

P/N 3081AE-CL

	THREAD	A	B	C	D
3081AE	M8 X 1.25	57	37	19	12
3081CG	M10 X 1.5	57	37	19	15

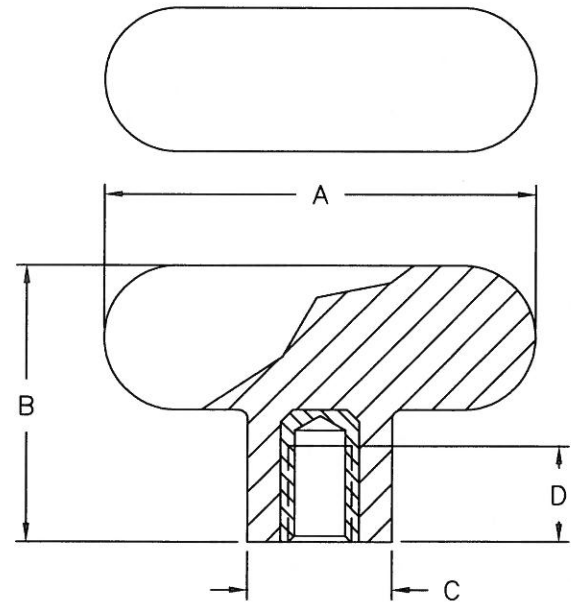

THREADED INTERNAL INSERT

	THREAD	A	B	C	D
3081CH	M8 X 1.25	57	37	19	20
3081CJ	M8 X 1.25	57	37	19	30
3081CK	M10 X 1.5	57	37	19	20
3081CL	M10 X 1.5	57	37	19	30

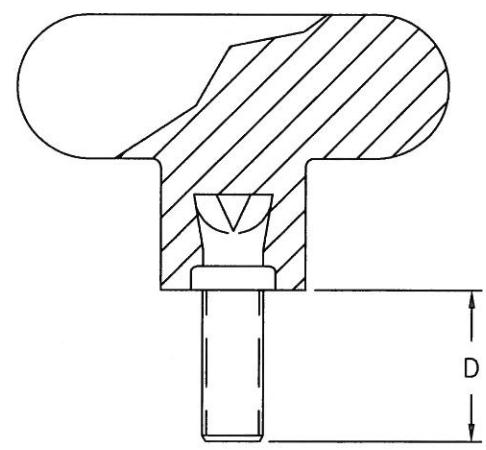

THREADED STUD

KNOB MATERIAL: POLYPROPYLENE  
COLOR: BLACK

INSERT MATERIAL: INTERNAL INSERTS ARE BRASS,  
PROJECTING STUDS ARE ZINC PLATED STEEL

TOLERANCES: UNLESS OTHERWISE SPECIFIED	DO NOT SCALE DRAWING			
	MM: X.XX ± 0.15MM X.X ± 0.4MM			
	ANG. ± 1°	CHANGES		