

RoHS COMPLIANT

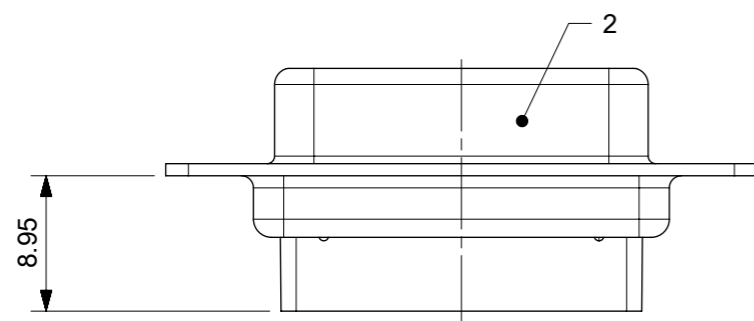

TABLE FOR PART NUMBERS

MOLEX PART#	FCT PART#	X-X	A [mm]	B [mm]	C [mm]	NO. OF CONTACTS 1./2./3. ROW
1731090036	FL09-15S7	09-15	30.8	16.4	25	5/5/5
1731130100	FL15-26S7	15-26	39.1	24.7	33.3	9/9/8
1731130102	FL25-44S7	25-44	53	38.5	47.04	15/15/14

X-X NO. OF CONTACTS 09-15, 15-26 or 25-44

TABLE FOR GENERAL TOLERANCES

PERMISSIBLE DEVIATIONS FOR BASIC SIZE RANGE				
0.5 UPTO	OVER 3 UPTO	OVER 6 UPTO	OVER 30 UPTO	OVER 120 UPTO
3	6	30	120	400
± 0.1	± 0.1	± 0.2	± 0.3	± 0.5

CRIMP CONTACTS NOT SUPPLIED WITH CONNECTOR.
CONTACTS MUST BE ORDERED SEPARATELY.

NO.	St.	PART	TYPE DESCRIPTION/MATERIAL	SURFACE PLATING/COLOUR/CLASS
2	1	SHELL	STEEL	TIN PLATED
1	1	INSULATOR	THERMOPLASTIC	BLACK

THIS DRAWING CONTAINS INFORMATION THAT IS PROPRIETARY TO MOLEX ELECTRONIC TECHNOLOGIES, LLC AND SHOULD NOT BE USED WITHOUT WRITTEN PERMISSION

DIMENSION UNITS mm	SCALE 2:1	CURRENT REV DESC: OBSOLETE PART NO	molex		
GENERAL TOLERANCES (UNLESS SPECIFIED)		EC NO: 615342			
ANGULAR TOL \pm	°	DRWN: AKUMAR19 2019/04/10	PRODUCT CUSTOMER DRAWING		
4 PLACES \pm		CHK'D: GB 2019/04/10	DOCUMENT NUMBER		
3 PLACES \pm		APPR: GGA 2019/04/10	1731090036		
2 PLACES \pm		INITIAL REVISION:	DOC TYPE	DOC PART	REVISION
1 PLACE \pm		DRWN: RLALSANGI 2017/04/19	PSD	000	B
0 PLACES \pm		APPR: ISHWARG 2017/06/07	SHEET NUMBER		
DRAFT WHERE APPLICABLE MUST REMAIN WITHIN DIMENSIONS	THIRD ANGLE PROJECTION	DRAWING	SERIES	MATERIAL NUMBER	CUSTOMER
		A3-SIZE	173109	SEE TABLE	GENERAL MARKET